

ADVERTISED PLAN

139-149 Boundary Road, North Melbourne

Transport Impact Assessment



This copied document to be made available for the sole purpose of enabling its consideration and review as part of a planning process under the Planning and Environment Act 1987. The document must not be used for any purpose which may breach any copyright

190608TIA002C-F
9 December 2021

This copied document to be made available for the sole purpose of enabling its consideration and review as part of a planning process under the Planning and Environment Act 1987. The document must not be used for any purpose which may breach any copyright





onemilegrid

ABN: 79 168 115 679

ADVERTISED PLAN

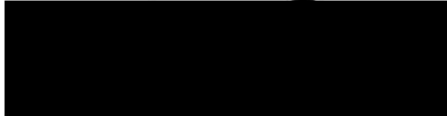

DOCUMENT INFORMATION

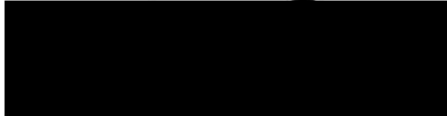
Prepared for	BEG Developments Pty Ltd	Report Date	9 December 2021
File Name	190608TIA002C-F	Reviewed by	
Prepared by		Signature	
Signature		Signature	

© One Mile Grid Pty Ltd. This document has been prepared by **onemilegrid** for the sole use and benefit of the client as per the terms of engagement. It may not be modified or altered, copied, reproduced, sold or transferred in whole or in part in any format to any person other than by agreement. **onemilegrid** does not assume responsibility or liability to any third party arising out of use or misuse of this document.

ADVERTISED PLAN



CONTENTS

1	INTRODUCTION.....	5
2	EXISTING CONDITIONS	5
2.1	Site Location	5
2.2	Planning Zones and Overlays.....	6
2.3	Road Network.....	7
2.3.1	Boundary Road	7
2.3.2	Alfred Street.....	8
2.4	Sustainable Transport	8
2.4.1	General	8
2.4.2	Public Transport	9
2.5	Walkability	10
2.6	Arden-Macaulay Structure Plan (2012)	11
3	DEVELOPMENT PROPOSAL.....	12
3.1	General	12
3.2	Access	12
3.3	Parking	12
3.3.1	Car Parking	12
3.3.2	Bicycle Parking	13
3.4	Waste Collection & Loading	13
4	DESIGN ASSESSMENT	14
4.1	Melbourne Planning Scheme – Clause 52.06.....	14
4.1.1	Design Standard 1 – Accessways	14
4.1.2	Design Standard 2 – Car Parking Spaces	14
4.1.3	Design Standard 3 – Gradients	15
4.2	Waste Collection.....	15
4.3	Reduced Height Clearance Parking	15
4.4	Bicycle Parking	16
4.4.1	Resident Spaces	16
4.4.2	Visitor Spaces	16
5	LOADING	16
6	BICYCLE PARKING	17
7	CAR PARKING	18
7.1	Statutory Car Parking Requirements.....	18
7.1.1	Car Parking Requirements – Clause 52.06	18
7.1.2	Proposed Car Parking Provision	18
7.2	Car Parking Demand Assessment	19
7.2.1	Residents	19
7.2.2	Retail.....	19
7.2.3	Building Manager	20
7.2.4	Overall Parking Demand	20
7.3	Review of Car Parking Provision.....	20
7.3.1	Impact of Parking Supply on Traffic Congestion	20
7.3.2	Local Planning Policy	21
7.3.3	On-Street Parking Restrictions.....	21
7.3.4	Alternative Modes of Transport	21
7.3.5	Adequacy of Proposed Car Parking Provision.....	22
8	TRAFFIC.....	22
8.1	Traffic Generation	22
8.1.1	Residential	22
8.1.2	Retail Tenancies & Building Manager	22
8.1.3	Total	22
8.2	Traffic Impact	23
9	CONCLUSIONS.....	23

TABLES

Table 1	Public Transport Provision.....	9
Table 2	Proposed Development	12
Table 3	Clause 52.06-9 Design Assessment – Design Standard 1	14
Table 4	Clause 52.34 – Bicycle Parking Requirements	17
Table 5	Clause 52.06 – Car Parking Requirements	18
Table 6	2016 Census Car Ownership – City of Melbourne – North Melbourne	19
Table 7	Proposed Car Parking Allocations	20
Table 8	Anticipated Traffic Generation	23

FIGURES

Figure 1	Site Location.....	5
Figure 2	Site Context (31 st August 2019)	6
Figure 3	Planning Scheme Zones.....	6
Figure 4	Principal Public Transport Network (PPTN) Area.....	7
Figure 5	Boundary Road looking north (left) and south (right) from the subject site	7
Figure 6	Alfred Street looking east (left) and west (right) from the subject site	8
Figure 7	TravelSmart Map	9
Figure 8	Public Transport Provision.....	10
Figure 9	Arden-Macaulay long-term land use strategy	11

APPENDICES

APPENDIX A	SWEPT PATH DIAGRAMS	24
------------	---------------------------	----

**This copied document to be made available
for the sole purpose of enabling
its consideration and review as
part of a planning process under the
Planning and Environment Act 1987.
The document must not be used for any
purpose which may breach any
copyright**

**ADVERTISED
PLAN**

1 INTRODUCTION

onemilegrid has been requested by BEG Developments Pty Ltd to undertake a Transport Impact Assessment of the proposed mixed-use development at 139-149 Boundary Road, North Melbourne.

As part of this assessment the subject site has been inspected with due consideration of the development proposal and relevant background reports have been reviewed.

This copied document to be made available for the sole purpose of enabling its consideration and review as part of a planning process under the Planning and Environment Act 1987. The document must not be used for any purpose which may breach any copyright.

2 EXISTING CONDITIONS

2.1 Site Location

The subject site is located on the western side of Boundary Road, north of the intersection with Alfred Street as shown in Figure 1 below. The site is addressed as 139-149 Boundary Road, North Melbourne.

Figure 1 Site Location

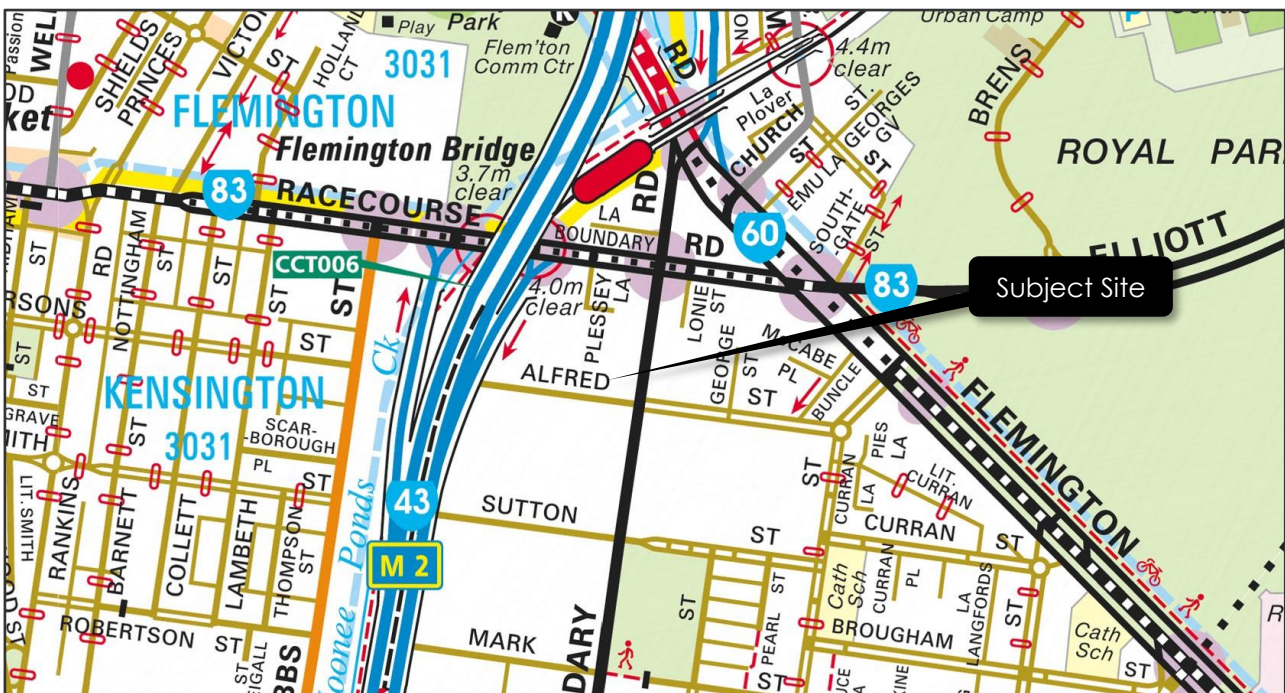

Copyright Melway Publishing

The site is currently vacant. The site is generally rectangular in shape with a frontage of 56 metres and an average site depth of 80 metres. The south western corner of the site protrudes to the south, and is approximately 25 metres long and 11 metres wide resulting in a frontage to Alfred Street of 11 metres.

The site currently has access to Boundary Road and Alfred Street. The previous HomyPed retail shopfront and warehouse provided staff and customer parking in an at grade car park, accessed via a crossover to Boundary Road, with a provision for 30 parking spaces. Access to the loading bay at the southwest corner of the building was provided via a crossover to Alfred Street.

Land use in the immediate vicinity is mixed, including a range of residential and commercial uses. Additionally, the site is located within the strategically defined Arden-Macaulay Urban Renewal Precinct which guides the future use and development of the area, discussed in Section 2.6.

An aerial view of the subject site in the context of its surrounds is provided in Figure 2.

This copied document to be made available for the sole purpose of enabling its consideration and review as part of a planning process under the Planning and Environment Act 1987. The document must not be used for any purpose which may breach any copyright.

Figure 2 Site Context (31st August 2019)



Copyright Nearmap

2.2 Planning Zones and Overlays

It is shown in Figure 3 that the site is located within a Mixed-Use Zone (MUZ), while Boundary Road is a Road Zone (RDZ1).

Additionally, the site is situated within the Principal Public Transport Network (PPTN) area, shown in Figure 4.

Figure 3 Planning Scheme Zones

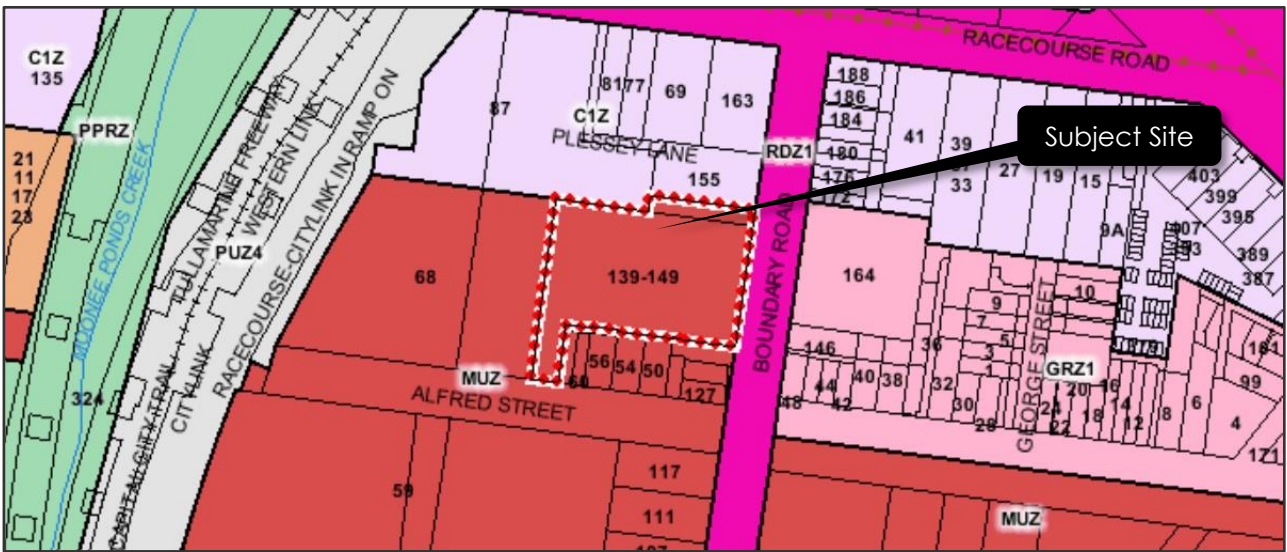

ADVERTISED PLAN

Figure 4 Principal Public Transport Network (PPTN) Area



2.3 Road Network

2.3.1 Boundary Road

Boundary Road is a major arterial road generally aligned north-south, running between Flemington Road in the north and Macaulay Road in the south.

Boundary Road provides a single traffic lane in each direction adjacent to the site with kerbside parking permitted on both sides. Kerbside parking is generally unrestricted on the eastern side of the road while parking on the western side is generally unrestricted but also subject to "No Stopping" between 4:30pm and 6:30pm along the northern half of the property frontage.

The cross-section of Boundary Road at the frontage of the site is shown in Figure 5.

Figure 5 Boundary Road looking north (left) and south (right) from the subject site

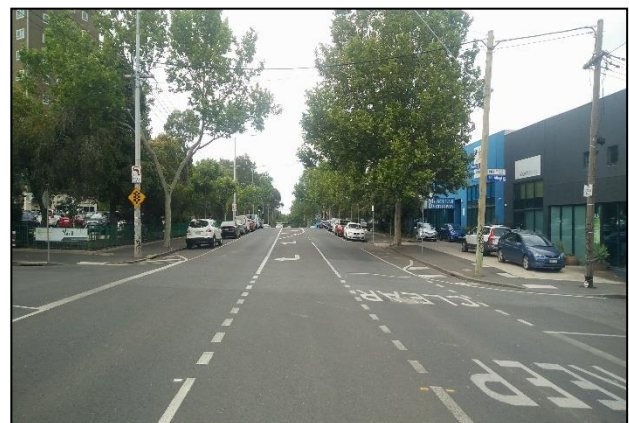

**ADVERTISED
PLAN**

2.3.2 Alfred Street

Alfred Street is a local road generally aligned east-west, running from Melrose Street in the east and terminating to the west of the site, alongside Citylink.

Alfred Street acts as a two-way roadway in the vicinity of the site, providing kerbside parking on both sides. Parking to the east of the site entrance is generally restricted to 2-hour parking 7:30am to 6:30pm Monday to Friday (Resident Permit Area 5 Excepted). The remaining parking along Alfred Street is generally unrestricted.

The cross-section of Alfred Street at the frontage of the site is shown in Figure 6.

Figure 6 Alfred Street looking east (left) and west (right) from the subject site



2.4 Sustainable Transport

2.4.1 General

An extract of the TravelSmart Map for the City of Melbourne is shown in Figure 7, highlighting the public transport, bicycle and pedestrian facilities in the area.

The site has excellent access to sustainable transport modes, with train, tram and bus services easily accessible from the site, and excellent access to formal and informal cycling routes.

Flemington Bridge Railway Station is located approximately 250 metres north from the site, offering excellent access to the Upfield train line as well as access to the Melbourne CBD. Newmarket Station is located approximately 1 kilometre west from the subject site and provides access to the Craigieburn train line and can be reached via tram.

Tram stops are located 100 metres to the north on Racecourse Road and 300 metres to the east on Flemington Road, providing connections through to the CBD and the northwest.

Flemington Road to the east and Macaulay Road to the south provide access to the metropolitan bus network in compliment to the above train services.

In addition to the public transport above, the site has good access to cycling routes, with the Moonee Ponds Creek Trail to the site's west providing excellent north-south connectivity, and various on-road routes including Racecourse Road and Flemington Road, providing further cycling connectivity.

**ADVERTISED
PLAN**

This copied document to be made available for the sole purpose of enabling its consideration and review as part of a planning process under the Planning and Environment Act 1987. The document must not be used for any purpose which may breach any copyright

Figure 7 TravelSmart Map

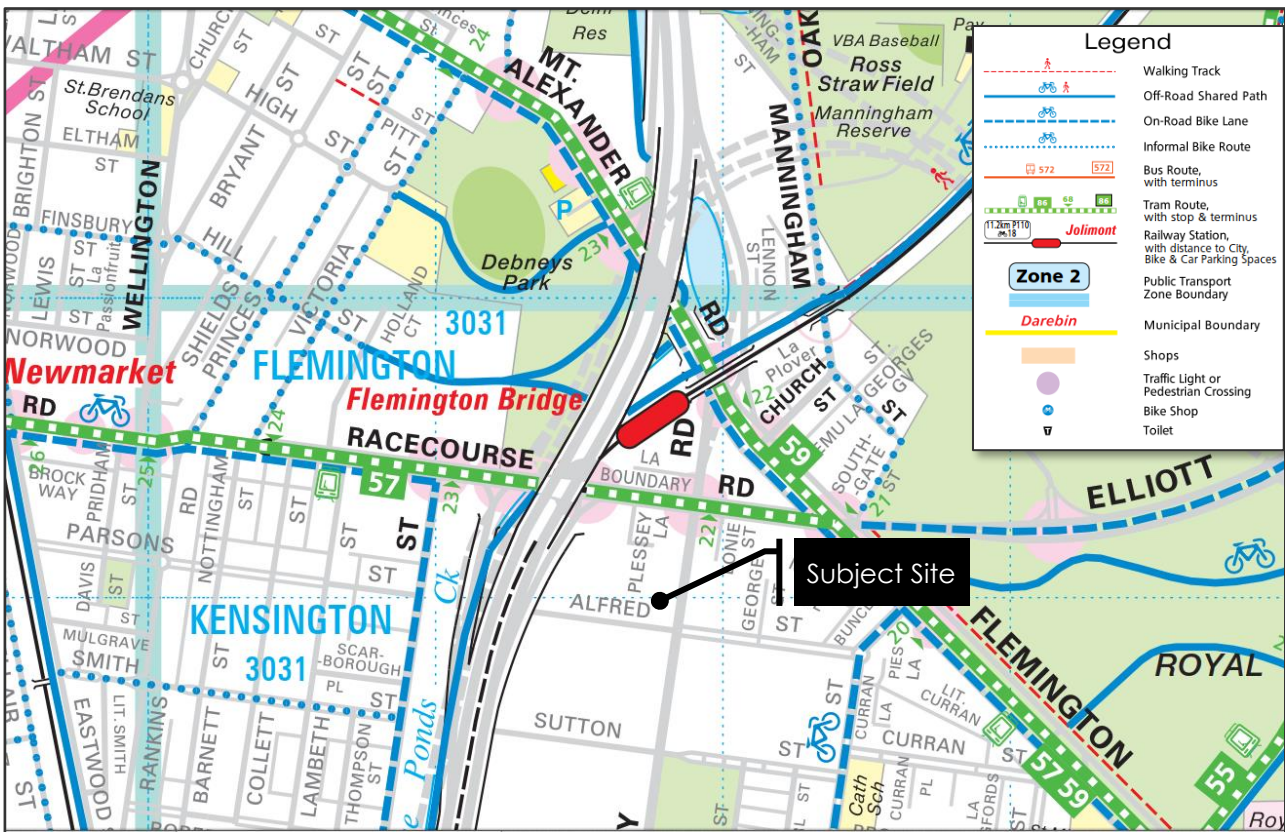

2.4.2 Public Transport

The full public transport provision in the vicinity of the site is detailed in Table 1 below and illustrated in Figure 8 overleaf.

The site has very good public transport accessibility, with a variety of services in the vicinity of the site.

Table 1 Public Transport Provision

Mode	Route No	Route Description	Nearest Stop/Station
Train		Craigieburn Line	Newmarket
		Upfield Line	Flemington Bridge
Tram	57	West Maribyrnong - Flinders Street Station, City	Racecourse Road
	59	Airport West - Flinders Street Station, City	Flemington Road
Bus	402	Footscray Station - East Melbourne via North Melbourne	Macaulay Road
	951	Night Bus - City - - Glenroy	Flemington Road

**ADVERTISED
PLAN**

This copied document to be made available for the sole purpose of enabling its consideration and review as part of a planning process under the Planning and Environment Act 1987. The document must not be used for any purpose which may breach any copyright

Figure 8 Public Transport Provision

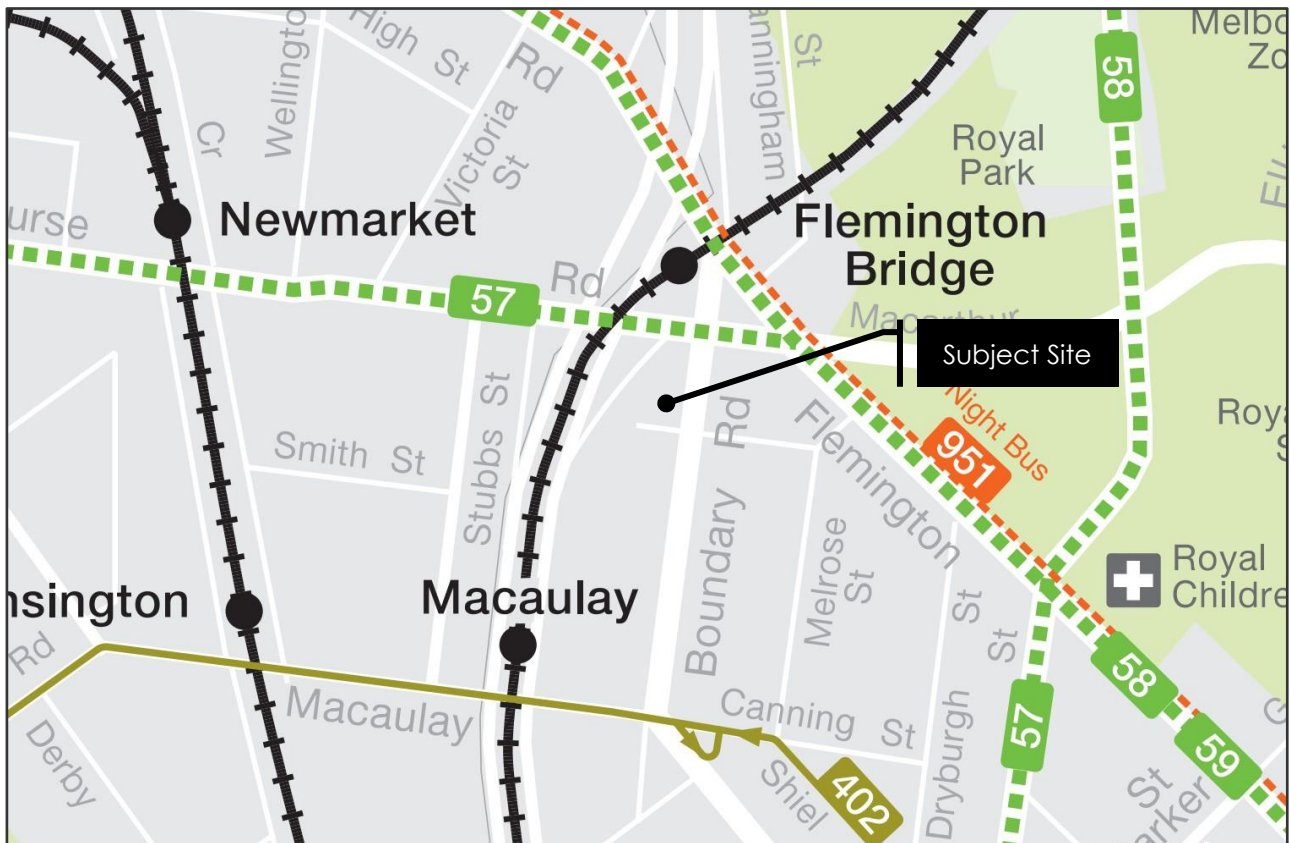

2.5 Walkability

Walkability is a measure of how friendly an area is to walking. Walkability has many health, environmental, and economic benefits. Factors influencing walkability include the presence or absence and quality of footpaths or other pedestrian rights-of-way, traffic and road conditions, land use patterns, building accessibility, and safety.

The site has a Walk Score rating of 83/100 and is very walkable, with most errands able to be accomplished on foot.

**ADVERTISED
PLAN**

This copied document to be made available for the sole purpose of enabling its consideration and review as part of a planning process under the Planning and Environment Act 1987. The document must not be used for any purpose which may breach any copyright

2.6 Arden-Macaulay Structure Plan (2012)

The site is located within the Arden-Macaulay Structure Plan area, for which an extract of the Structure Plan 'Long-term land use strategy map' is shown in Figure 9. The Arden-Macaulay Structure Plan considers strategies to stage the urban renewal across the Arden-Macaulay precinct.

As can be seen below, the site is in an area proposed for mixed-use activities. Furthermore, Racecourse Road to the north of the site is planned to become a new activity centre.

Figure 9 Arden-Macaulay long-term land use strategy

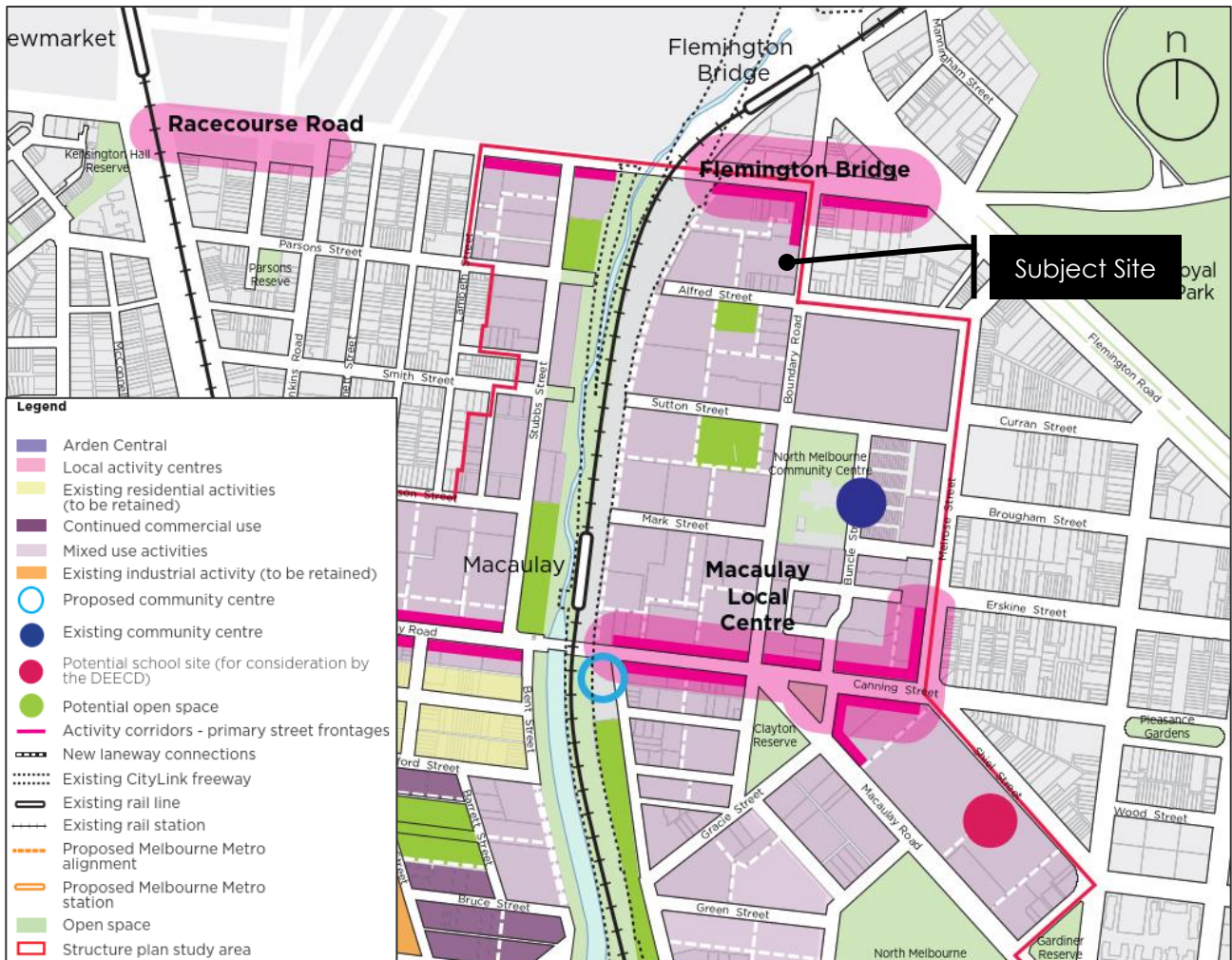

**ADVERTISED
PLAN**

This copied document to be made available for the sole purpose of enabling its consideration and review as part of a planning process under the Planning and Environment Act 1987. The document must not be used for any purpose which may breach any copyright

3 DEVELOPMENT PROPOSAL

3.1 General

It is proposed to develop the site for the purposes of a mixed-use development, comprising apartments, townhouses, communal amenities and two retail tenancies at the Boundary Road frontage.

The development schedule for the proposed mixed-use development is shown below in Table 2.

Table 2 Proposed Development

Use	Component	No./Area
Dwellings	1-Bedroom Apartment	102
	2-Bedroom Apartment	169
	3-Bedroom Townhouse	5
	Total	276
Shop	Retail Tenancy 1	69.6m ²
	Retail Tenancy 2	71.4m ²
	Total	141m²
Café	Café Tenancy 1	101.5m ²
	Total	101.5m²

Communal amenities proposed include a gymnasium, wellness centre, private dining room, arcade games room and various communal open space areas. These will be accessible only to residents of the development, and are ancillary to the primary use.

3.2 Access

Pedestrian and cyclist access to the site will primary be provided from Boundary Road, with the entrance lobby located toward the south-east corner of the site, and access to retail tenancies provided from the proposed widened footpath. An additional pedestrian and cyclist access will be provided along the western boundary from Alfred Street, linking back to the main lobby.

Vehicular access to the site is proposed via a crossover and two-way accessway to the Alfred Street frontage, linking to a basement car park and waste collection / loading area.

3.3 Parking

3.3.1 Car Parking

Car parking is proposed across three basement car parking levels, arranged in half levels with two levels within the western portion of the site and three levels in the eastern portion with a total of 234 parking spaces. Of these, 225 spaces will be allocated to residents, eight spaces will be allocated to the commercial tenancies including one accessible bay, and one space allocated to the building manager.

**ADVERTISED
PLAN**

This copied document to be made available for the sole purpose of enabling its consideration and review as part of a planning process under the Planning and Environment Act 1987. The document must not be used for any purpose which may breach any copyright

3.3.2 Bicycle Parking

A total of 225 bicycle parking spaces are proposed within the development, with 76 spaces provided for visitors and 149 spaces for residents.

The resident spaces are provided throughout the basement levels with the majority being provided adjacent the lift core within basement level 2. The resident spaces are proposed to be provided at vertically staggered bicycle racks.

The visitor bicycle parking spaces are provided on the ground level at horizontal bicycle hoops in front of the retail tenancies and near the Alfred Street frontage.

3.4 Waste Collection & Loading

Waste collection and loading will be accommodated on the basement level, accessed via the Alfred Street access.

The loading bay will facilitate service vehicles up to 9.8 metres length and 4m height, permitting loading and unloading of retail goods, residential removalists, and collection of bins.

Further details of waste management are provided within the Waste Management Plan prepared by **onemilegrid** (OMG ref: 190608WMP001).

**ADVERTISED
PLAN**

This copied document to be made available for the sole purpose of enabling its consideration and review as part of a planning process under the Planning and Environment Act 1987. The document must not be used for any purpose which may breach any copyright

4 DESIGN ASSESSMENT

4.1 Melbourne Planning Scheme – Clause 52.06

onemilegrid has undertaken an assessment of the car parking layout and access for the proposed development with due consideration of the Design Standards detailed within Clause 52.06-9 of the Planning Scheme. A review of those relevant Design Standards is provided in the following section.

4.1.1 Design Standard 1 – Accessways

A summary of the assessment for Design Standard 1 is provided in Table 3.

Table 3 Clause 52.06-9 Design Assessment – Design Standard 1

Requirement	Comments
Be at least 3 metres wide	Satisfied – Minimum width of accessways is 6.1 metres
Have an internal radius of at least 4 metres at changes of direction or intersection or be at least 4.2 metres wide	Satisfied – Accessways in excess of 4.2 metres width at changes of direction
Allow vehicles parked in the last space of a dead-end accessway in public car parks to exit in a forward direction with one manoeuvre	N/A – Private car park
Provide at least 2.1 metres headroom beneath overhead obstructions, calculated for a vehicle with a wheel base of 2.8 metres	Satisfied – Height clearances in excess of 2.1 metres provided throughout
If the accessway serves four or more car spaces or connects to a road in a Road Zone, the accessway must be designed so that cars can exit the site in a forward direction	Satisfied – All vehicles may exit in a forward direction
Provide a passing area at the entrance at least 6.1 metres wide and 7 metres long if the accessway serves ten or more car parking spaces and is either more than 50 metres long or connects to a road in a Road Zone	Satisfied – Accessway from Alfred Street is 6.1 metres wide along its length
Have a corner splay or area at least 50 per cent clear of visual obstructions extending at least 2 metres along the frontage road from the edge of an exit lane and 2.5 metres along the exit lane from the frontage, to provide a clear view of pedestrians on the footpath of the frontage road. The area clear of visual obstructions may include an adjacent entry or exit lane where more than one lane is provided, or adjacent landscaped areas, provided the landscaping in those areas is less than 900mm in height.	Generally satisfied – A partial splay is provided on the eastern side of the exit lane. It is recommended that a convex mirror be installed to assist with sightlines to the east
If an accessway to four or more car parking spaces is from land in a Road Zone, the access to the car spaces must be at least 6 metres from the road carriageway.	N/A – Site is not accessed from a Road Zone. Regardless, all spaces are at least 6 metres from the road carriageway

4.1.2 Design Standard 2 – Car Parking Spaces

All car spaces on-site are proposed with dimensions as specified in Table 2 of Design Standard 2 in accordance with the Planning Scheme requirements.

This copied document to be made available for the sole purpose of enabling its consideration and review as part of a planning process under the Planning and Environment Act 1987. The document must not be used for any purpose which may breach any copyright

Where parking spaces are provided in tandem an additional 500mm in length has been provided between each space.

Dead-end aisles have been extended by at least 500mm beyond the end car space to assist with entry and exit manoeuvres. Swept path diagrams are provided in Appendix A demonstrating access to and from these spaces in accordance with the Australian Standard requirements.

Spaces adjacent to walls have been provided with clearance of 300mm or suitably widened in accordance with Design Standard 2 of the Planning Scheme.

A number of columns throughout the basement are located within the clearance zones of Diagram 1 within Clause 52.06. Where structural constrains permit, it is recommended that columns are positioned in accordance with the requirements of Clause 52.06 to ensure adequate access is provided to each parking space.

The accessible bay is provided with a length of 5.4 metres and a width of 2.4 metres, and an adjacent shared area of the same dimensions, in accordance with the Australian Standard for Off-Street Parking for People with Disabilities AS2890.6. Similar to the above, 300mm clearance from columns, obstructions and walls should be provided where practical.

4.1.3 Design Standard 3 – Gradients

The Alfred Street ramp has been designed with 7 metre grade transitions of 1:16 and a maximum grade of 1:8 to facilitate access by trucks, and avoid scraping or bottoming out.

The remainder of internal ramps are provided with a maximum grade of 1:4 and transitions are provided where changes of grade exceed 12.5%, and transition lengths have been designed to prevent potential scraping, in accordance with the requirements of Design Standard 3.

4.2 Waste Collection

A bin storage area is located within the basement car park adjacent the proposed loading area. The waste collection vehicle will enter the basement from Alfred Street, reverse into the waste collection area, empty the bins and then exit the site in a forward direction.

The Alfred Street ramp and accessways in the vicinity of the waste collection area have been designed to accommodate a 9.8 metre length Council waste collection vehicle. A minimum clear height of 4 metres is provided to the ceiling.

Swept path diagrams are provided in Appendix A demonstrating the waste collection vehicle entering the compactor storage area and exiting the site in a forward direction.

Refer to the Waste Management Plan for further information.

4.3 Reduced Height Clearance Parking

Within the basement car park, it is proposed to provide an over-bonnet storage cage above a number of the standard car spaces. The storage cages will sit no less than 1.2 metres above the finished floor level of the basement and will extend no more than 1.0 metre into the space.

This will ensure that these spaces remain accessible for the vast majority of vehicles.

It is acknowledged that strictly, a clear height of 2.1 metres is required above each car space. In this regard, it is considered that based on the recorded typical dimensions, the fact that spaces are allocated to permanent residents where the occupier of the space will be familiar with the car space and any potential restrictions, this is acceptable. For larger vehicles, the proposed storage box could potentially encroach on the required vehicle clearance. In this case, the resident can remove the storage box if required.

This copied document to be made available for the sole purpose of enabling its consideration and review as part of a planning process under the Planning and Environment Act 1987. The document must not be used for any purpose which may breach any

In view of the above the proposed over-bonnet storage cages are considered acceptable.

In addition to the above, there are a number of spaces located underneath the internal ramps with a minor encroachment at the front of the parking space, reducing the clear height to 2 metres. It is recommended that any storage for the dwellings allocated these spaces is not provided as over bonnet storage. This is considered to be acceptable.

4.4 Bicycle Parking

4.4.1 Resident Spaces

It is proposed to provide resident bicycle spaces at vertically mounted and staggered bicycle racks across the basement and lower ground levels. The individual bicycle racks are separated by 500mm, which provides a separation of 1 metre between bicycles at the same level, in excess of the Planning Scheme requirements, and in accordance with typical advice from Bicycle Network Victoria.

An access aisle of 1.5 metres is provided for the bicycle racks, in accordance with the Australian Standard requirements.

It is recommended that 20% of the resident spaces be provided at horizontal bicycle racks in accordance with the Australian Standard for Bicycle Parking.

4.4.2 Visitor Spaces

The visitor bicycle spaces are proposed to be provided at bicycle hoops. The hoops have been provided at 1 metre centres and an envelope length of 1.8 metres, accessed from a 1.5 metre aisle in accordance with the Australian Standards.

5 LOADING

Clause 65 (Decision Guidelines) of the Melbourne Planning Scheme identifies that “*Before deciding on an application or approval of a plan, the responsible authority must consider, as appropriate: The adequacy of loading and unloading facilities and any associated amenity, traffic flow and road safety impacts.*”

The proposal includes a basement loading bay, accessible by service vehicles up to 9.8 metres length and 4 metres in height, and will permit loading and unloading of retail goods, residential removalists, and collection of waste bins.

In addition, an existing on-street loading area is provided along Boundary Road at the centre of the site frontage, which may assist in accommodating other loading activity.

The provision for loading is therefore considered appropriate for the proposed use.

**ADVERTISED
PLAN**

This copied document to be made available for the sole purpose of enabling its consideration and review as part of a planning process under the Planning and Environment Act 1987. The document must not be used for any purpose which may breach any copyright

6 BICYCLE PARKING

The bicycle parking requirements for the subject site are identified in Clause 52.34 of the Melbourne Planning Scheme, which specifies the following requirements for the different components of the proposed development.

Table 4 Clause 52.34 – Bicycle Parking Requirements

Component	No/Area	Requirement	Total
Dwelling (four or more storeys)	276 dwellings	1 space per 5 dwellings for residents	55
		1 space per 10 dwellings for visitors	28
Shop (greater than 1000m ²)	242.5 m ²	1 space per 600m ² for employees	0
		1 space per 500m ² for visitors	0
Total		Residents	55
		Employees	0
		Visitors	28

Based on the above calculations, there is a requirement to provide 83 bicycle spaces for the development including 55 spaces for residents and 28 spaces for visitors.

It is proposed to provide a total of 225 bicycle parking spaces comprising 76 visitor spaces and 149 resident spaces within the basement and lower ground levels.

Considering the above, the proposed provision of resident and visitor bicycle parking exceeds the requirements of the Planning Scheme, and is therefore considered appropriate.

ADVERTISED PLAN

This copied document to be made available for the sole purpose of enabling its consideration and review as part of a planning process under the Planning and Environment Act 1987. The document must not be used for any purpose which may breach any copyright

7 CAR PARKING

7.1 Statutory Car Parking Requirements

7.1.1 Car Parking Requirements – Clause 52.06

The car parking requirements for the subject site are identified in Clause 52.06 of the Melbourne Planning Scheme. Clause 52.06 identifies that where any part of the land is identified as being within the Principal Public Transport Network Area, the Column B car parking rates apply to the proposed development.

As shown in Figure 4, the site is located within the Principal Public Transport Network Area, and therefore, the Column B rates apply, as shown below.

Table 5 Clause 52.06 – Car Parking Requirements

Use	No/Area	Rate	Car Parking Measure	Total
Dwelling	271 dwellings	1	to each one or two bedroom dwelling, plus	271
	5 dwellings	2	to each three or more bedroom dwelling (with studies or studios that are separate rooms counted as bedrooms), plus	10
	276 dwellings	0	for visitors to every 5 dwellings for developments of 5 or more dwellings	0
Shop	242.5m ²	3.5	to each 100m ² of leasable floor area	8
Total				289

Based on the above calculations, a total of 289 parking spaces are required for the proposed development comprising 281 resident spaces and eight spaces for the retail uses.

7.1.2 Proposed Car Parking Provision

It is proposed to provide a total of 236 car parking spaces on-site, which equates to a shortfall of 53 spaces when compared to the Planning Scheme requirements.

In this regard, Clause 52.06-7 of the Melbourne Planning Scheme indicates that an application to reduce (including reduce to zero) the requirement for car spaces must be accompanied by a Car Parking Demand Assessment. The Assessment must assess the car parking demand likely to be generated by the proposed development, having consideration to:

- The likelihood of multi-purpose trips within the locality which are likely to be combined with a trip to the land in connection with the proposed use.
- The variation of car parking demand likely to be generated by the proposed use over time.
- The short-stay and long-stay car parking demand likely to be generated by the proposed use.
- The availability of public transport in the locality of the land.
- The convenience of pedestrian and cyclist access to the land.
- The provision of bicycle parking and end of trip facilities for cyclists in the locality of the land.
- The anticipated car ownership rates of likely or proposed visitors to or occupants (residents or employees) of the land.
- Any empirical assessment or case study.

An assessment of the likely parking demands and the appropriateness of reducing the car parking provision below them is set out below.

This copied document to be made available for the sole purpose of enabling its consideration and review as part of a planning process under the Planning and Environment Act 1987. The document must not be used for any purpose which may breach any copyright

7.2 Car Parking Demand Assessment

7.2.1 Residents

It is anticipated that the parking demands for the 3-bedroom townhouses will be in accordance with the Planning Scheme requirements. The 3-bedroom townhouses are therefore expected to generate a demand for 10 parking spaces.

In order to determine the likely resident parking demands for the 1-bedroom and 2-bedroom apartments, car ownership data was sourced from the Australian Bureau of Statistics (ABS) for the 2016 Census.

For development types similar to that proposed, located within the North Melbourne SA2 Region, the data is outlined in Table 6.

Table 6 2016 Census Car Ownership – City of Melbourne – North Melbourne

Dwelling Type	No of Bedrooms	Sample Size	Average Car Ownership
Flat, unit or apartment	1	944	0.37
	2	1,209	0.66

Application of the above rates to the proposed apartment mix gives an estimated average parking demand for 150 spaces. Considering the location of the site, and its proximity to local amenities and public transport, it is expected that the average parking rates above will be representative of residents demands.

The ABS data was further assessed to determine the proportion of dwellings where residents do not own or otherwise have the need to park a vehicle at their place of residence. The data identifies that residents of 67% of one-bedroom dwellings and residents of 46% of two-bedroom dwellings do not own or otherwise park a vehicle at their place of residence.

The ABS data clearly indicates that there is a market for dwellings, particularly one and two-bedrooms, that do not provide, and therefore do not attract the price premium associated with a car parking space in this location. Given the site's location with respect to public transport services and other services, it is expected that dwellings within the subject site would be particularly appealing to potential owners/tenants who do not have the need to park a vehicle at their place of residence.

Furthermore, it should be recognised that resident parking demands are, in part, dependent on car parking provisions, insofar as an owner/tenant with the need to park a vehicle is unlikely to occupy a dwelling that does not provide a car parking space. This is particularly true in areas where on-street parking is restricted to short durations, meaning on-street parking is not a viable alternative to on-site parking for residents.

With the site's location to public transport and other amenities, and on-street parking in the area generally being restricted, it is considered reasonable to assume that resident parking demands will be in the order of 160 parking spaces.

7.2.2 Retail

With respect to the ground floor retail tenancies, it is anticipated that the bulk of patronage will be generated by the upper levels, residents in the area and from other nearby uses. As a result, parking demands are expected to only be attributable to staff.

For the purposes of the following assessment, the retail uses will be assumed to generate staff parking demands in accordance with the Planning Scheme requirements, equivalent to 8 spaces.

Staff demands are typically dictated by supply of parking and availability of on-street parking.

This copied document to be made available for the sole purpose of enabling its consideration and review as part of a planning process under the Planning and Environment Act 1987. The document must not be used for any purpose which may breach any copyright

7.2.3 Building Manager

The building manager is expected to generate a demand for one parking space.

7.2.4 Overall Parking Demand

Based on the above assessment, it is expected that the development will generate a total parking demand of 164 spaces, with the proposed allocation shown in Table 7.

Table 7 Proposed Car Parking Allocations

Use	Component	No./Area	Demand	Allocation	Surplus/ (Shortfall)
Dwellings	1-Bedroom Apartment	102	38	45	7
	2-Bedroom Apartment	169	112	169	57
	3-Bedroom Townhouse	5	10	10	-
Shop	Retail Tenancy 1	69.6m ²	2	2	-
	Retail Tenancy 2	71.4m ²	2	2	-
Café	Café Tenancy 1	101.5m ²	4	4	-
Commercial	Accessible Space	-	1	1	-
Building Manager			1	1	-
Total			165	234	69

The commercial tenancies will be allocated tandem parking spaces to provide on-site car parking. Each tandem pair will only be allocated to a single tenancy.

The provision of car parking is therefore considered to be appropriate to satisfy the parking demands generated by the development.

This copied document to be made available for the sole purpose of enabling its consideration and review as part of a planning process under the Planning and Environment Act 1987. The document must not be used for any purpose which may breach any copyright

7.3 Review of Car Parking Provision

7.3.1 Impact of Parking Supply on Traffic Congestion

A recent VCAT decision (Ronge v Moreland CC [2017] VCAT 550 (9 May 2017)) highlighted the value of reduced car parking provision with regard to traffic congestion, identifying the potential adverse impact of providing parking to comply with Clause 52.06, as below:

“Our roads are already congested and will be unimaginably so if a ‘business-as-usual’ approach is accepted through until 2050. The stark reality is that the way people move around Melbourne will have to radically change, particularly in suburbs so well served by different modes of public transport and where cycling and walking are practical alternatives to car based travel.

A car parking demand assessment is called for by Clause 52.06-6 [now Clause 52.06-7] when there is an intention to provide less car parking than that required by Clause 52.06-5. However, discussion around existing patterns of car parking is considered to be of marginal value given the strong policy imperatives about relying less on motor vehicles and more on public transport, walking and cycling. Census data from 2011 or 2016 is simply a snapshot in time, a base point, but such data should not be given much weight in determining what number of car spaces should be provided in future, for dwellings with different bedroom numbers.

Policy tells us the future must be different.

Oversupplying parking, whether or not to comply with Clause 52.06, has the real potential to undermine the encouragement being given to reduce car based travel in favour of public transport, walking and cycling."

"One of the significant benefits of providing less car parking is a lower volume of vehicle movements and hence a reduced increase in traffic movements . . ."

7.3.2 Local Planning Policy

The subject site is identified as part of an "Urban Renewal Area' within the Growth Area Framework Plan within Clause 21.04 of the Melbourne Planning Scheme.

Clause 21.09 outlines a number of strategies considered relevant to the proposal including:

- Integrated Transport Strategy 1.2 - Encourage development in locations, which can maximise the potential use of public transport.
- Integrated Transport Strategy 1.4 - Consolidate development with a mix of uses along tram and bus corridors and at and around railway stations in Urban Renewal Areas.
- Public Transport Strategy 1.2 - Consolidate development with a mix of uses along tram and bus corridors and at and around railway stations in Urban Renewal Areas
- Public Transport Strategy 1.4 - Encourage public transport as the primary mode of access to the Central City
- Private Motor Transport Strategy 1.5 - Support the reduction or waiving of car parking for new uses and developments, which have good access to public transport.

7.3.3 On-Street Parking Restrictions

For developments with reduced parking supply, and where on-street parking in the area is unrestricted, it is often observed that long term resident or employee parking may occur on-street. Conversely, where on-street parking surrounding a development with a reduced parking supply is restricted, residents with lower car ownership levels are encouraged to occupy the development, knowing that long-term parking is generally unavailable in the area if they are not provided with an on-site parking space.

A review of parking restrictions in the area surrounding the proposed development indicates that on-street parking is heavily restricted, and there is limited opportunity for long term resident and staff parking in the area.

These restrictions are therefore expected to ensure that residents without allocated parking, and employees without allocation parking do not own a vehicle or drive one to the site for work, as they will not be able to conveniently park their vehicle long-term on-street in the vicinity of the site.

7.3.4 Alternative Modes of Transport

As indicated in Section 2.4 the site has excellent access to Public Transport, with numerous tram and bus services in the immediate vicinity, and good access to bicycle routes. This accessibility to sustainable transport modes ensures that residents, visitors and staff of the development will have realistic means to access the site other than by car.

Furthermore, the development is to provide bicycle parking numbers over and above the Clause 52.34 requirements, in convenient locations for short and long-term visitors to the site.

**ADVERTISED
PLAN**

This copied document to be made available for the sole purpose of enabling its consideration and review as part of a planning process under the Planning and Environment Act 1987. The document must not be used for any purpose which may breach any copyright

7.3.5 Adequacy of Proposed Car Parking Provision

It is expected that the proposed supply of car parking is appropriate for the proposed development, considering the following:

- The proposed development provides bicycle parking in excess of the Planning Scheme requirements, therefore providing an alternate means of transportation;
- The site has excellent access to public transport, with numerous tram and bus services in the immediate vicinity, providing access options for residents and employees with no on-site parking space;
- Existing parking restrictions in the area will encourage residents and employees with low car ownership rates, and ensure staff do not park long-term on-street;
- Reduced car parking provision assists with the desired reduction in private vehicle usage, therefore minimising traffic impacts in the vicinity.

This copied document to be made available for the sole purpose of enabling its consideration and review as part of a planning process under the Planning and Environment Act 1987. The document must not be used for any purpose which may breach any copyright

8 TRAFFIC

8.1 Traffic Generation

8.1.1 Residential

Surveys undertaken by other traffic engineering firms at residential dwellings have shown that the daily traffic generation rates vary depending on the size, location and type of the dwelling, the parking provision and proximity to local facilities and public transport.

Medium to high density dwellings in inner areas generate traffic with rates between 3.0 and 6.0 movements per dwelling. Considering the location of the subject site and moreover the excellent access to public transport, it is expected that generation rates will be towards the lower end of the range. Nevertheless, for the purposes of this assessment a daily rate of in the order of 3.0 movements per day per dwelling will be adopted with 10% occurring during the peak hours.

Application of the above rates indicates that the 219 dwellings with car parking will generate 657 movements per day, inclusive of approximately 66 vehicle movements during each of the morning and afternoon peak hours.

During the morning peak, it is estimated that 80% of the residential traffic will be outbound, while during the afternoon peak, 60% of the residential traffic will be inbound.

It is therefore anticipated that the 66 projected vehicle movements will comprise 13 arrival and 53 departures during the AM peak and 40 arrivals and 26 departures during the PM peak.

8.1.2 Retail Tenancies & Building Manager

With regard to the retail tenancies and building manager, it is anticipated that each allocated parking space may generate one inbound trip during the AM peak period, and one outbound trip during the PM peak period, equivalent to nine vehicle trips per hour.

8.1.3 Total

Based on the above expected traffic generation for each use, the anticipated traffic generated by the proposed development is shown in Table 8.

Table 8 Anticipated Traffic Generation

<i>Period</i>	<i>Inbound</i>	<i>Outbound</i>	<i>Total</i>
AM Peak	22	53	75
PM Peak	40	35	75

8.2 Traffic Impact

The majority of traffic generated is anticipated to be to and from the north, to access Racecourse Road, Citylink and Flemington Road, with the remainder of traffic generated to the south via Boundary Road or east via Alfred Street.

When considering the split of inbound and outbound vehicles, and further distributions to the left and right on Alfred Street, the additional traffic generated to each individual movement will be relatively low, considerably less than one additional movement each minute, is not expected to have a significant impact on the surrounding road network.

It is further noted that the site's redevelopment will remove all traffic associated with the existing use, and the associated at-grade car park accessed from Boundary Road.

The proposed access arrangements and traffic generation are therefore considered acceptable.

9 CONCLUSIONS

It is proposed to develop the subject site for the purposes of a mixed-use development comprising 276 dwellings and three retail tenancies, with car parking provided across three basement levels.

Considering the analysis presented above, it is concluded that:

- The proposed car parking and access design is considered appropriate;
- The proposed resident and visitor bicycle parking design is considered appropriate;
- The loading bay has been designed adequately to allow for Council waste collection services and loading/unloading needs of the development;
- The proposed provision of resident and visitor bicycle parking exceeds the requirements of the Planning Scheme, and is therefore considered appropriate;
- The proposed supply of car parking is appropriate for the proposed development;
- The proposed development is not expected to have a significant impact on the surrounding road network; and
- There are no traffic engineering reasons which should preclude a permit from being issued for this proposal.

**ADVERTISED
PLAN**

This copied document to be made available for the sole purpose of enabling its consideration and review as part of a planning process under the Planning and Environment Act 1987. The document must not be used for any purpose which may breach any copyright

Appendix A Swept Path Diagrams

**ADVERTISED
PLAN**

This copied document to be made available for the sole purpose of enabling its consideration and review as part of a planning process under the Planning and Environment Act 1987. The document must not be used for any purpose which may breach any copyright



CAD File: N:\Projects\2019\190608\Drawings\190608SPA100.dgn

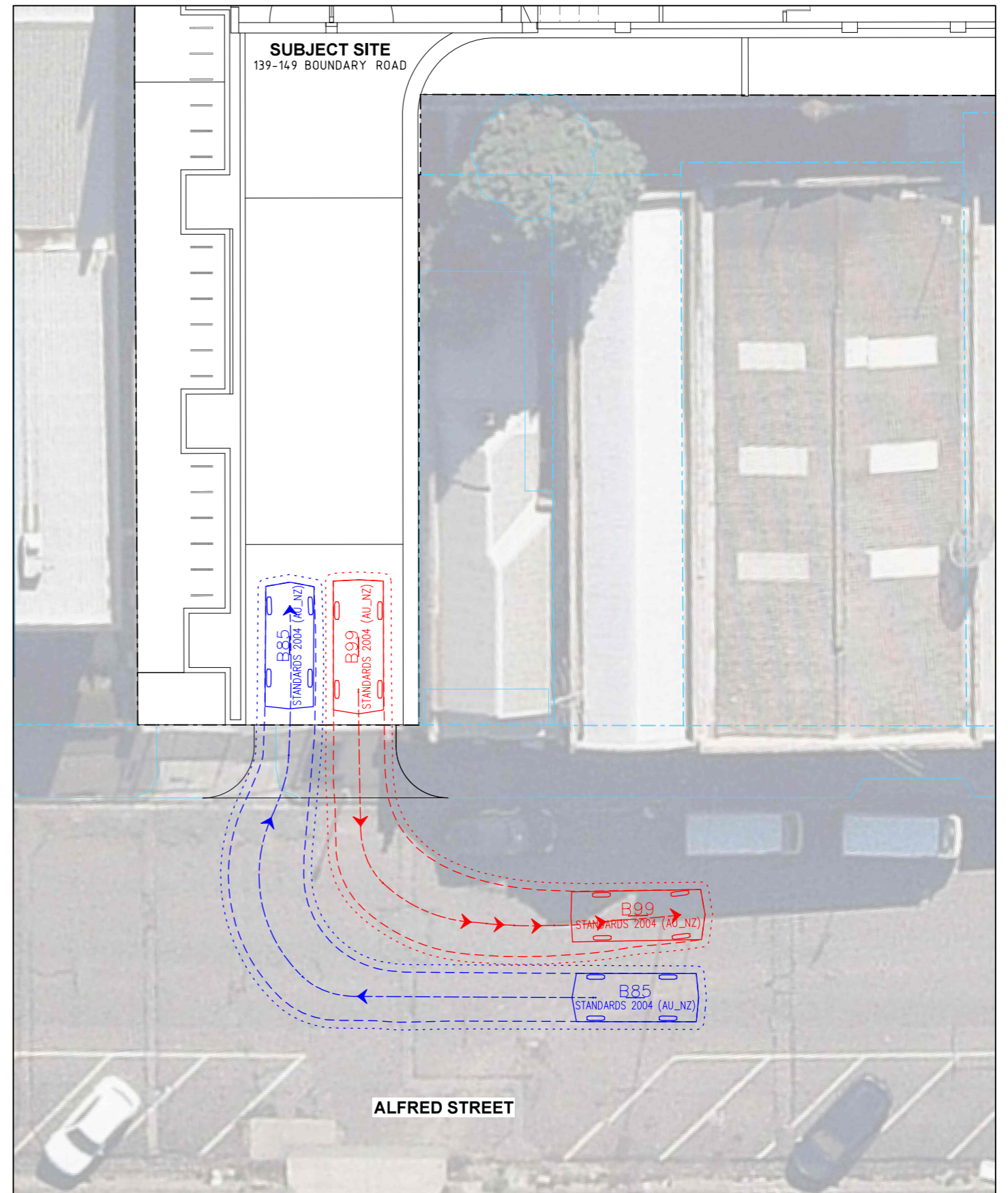

Date Plotted: 23-09-2021 15:04:32 PM

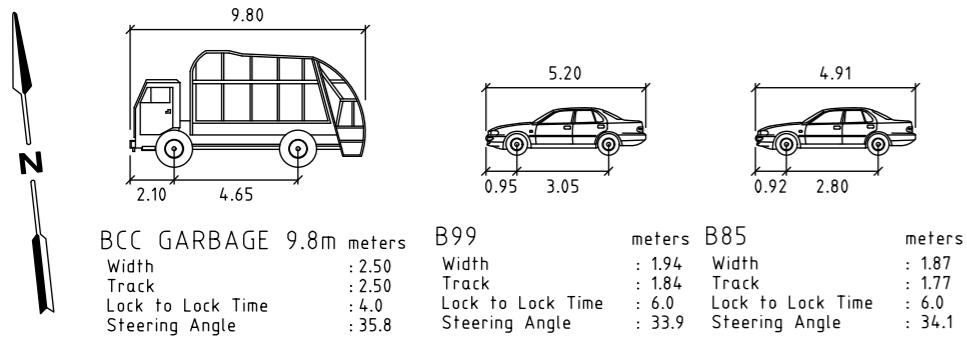

This copied document to be made available for the sole purpose of enabling its consideration and review as part of a planning process under the Planning and Environment Act 1987. The document must not be used for any purpose which may breach any **copyright**

ADVERTISED PLAN



Scale: 1:200 @ A3

Drawing Title 139-149 BOUNDARY RD, NORTH MELBOURNE GROUND LEVEL - VEHICLE SITE ACCESS SWEEP PATH ANALYSIS		
Designed RG	Approved JD	Metway Ref 43 B11
Project Number 190608	Drawing Number SPA100	Revision E

CAD File: N:\Projects\2019\190608\Drawings\190608SPA101.dgn

Date Plotted: 23-09-2021 5:05:21 PM

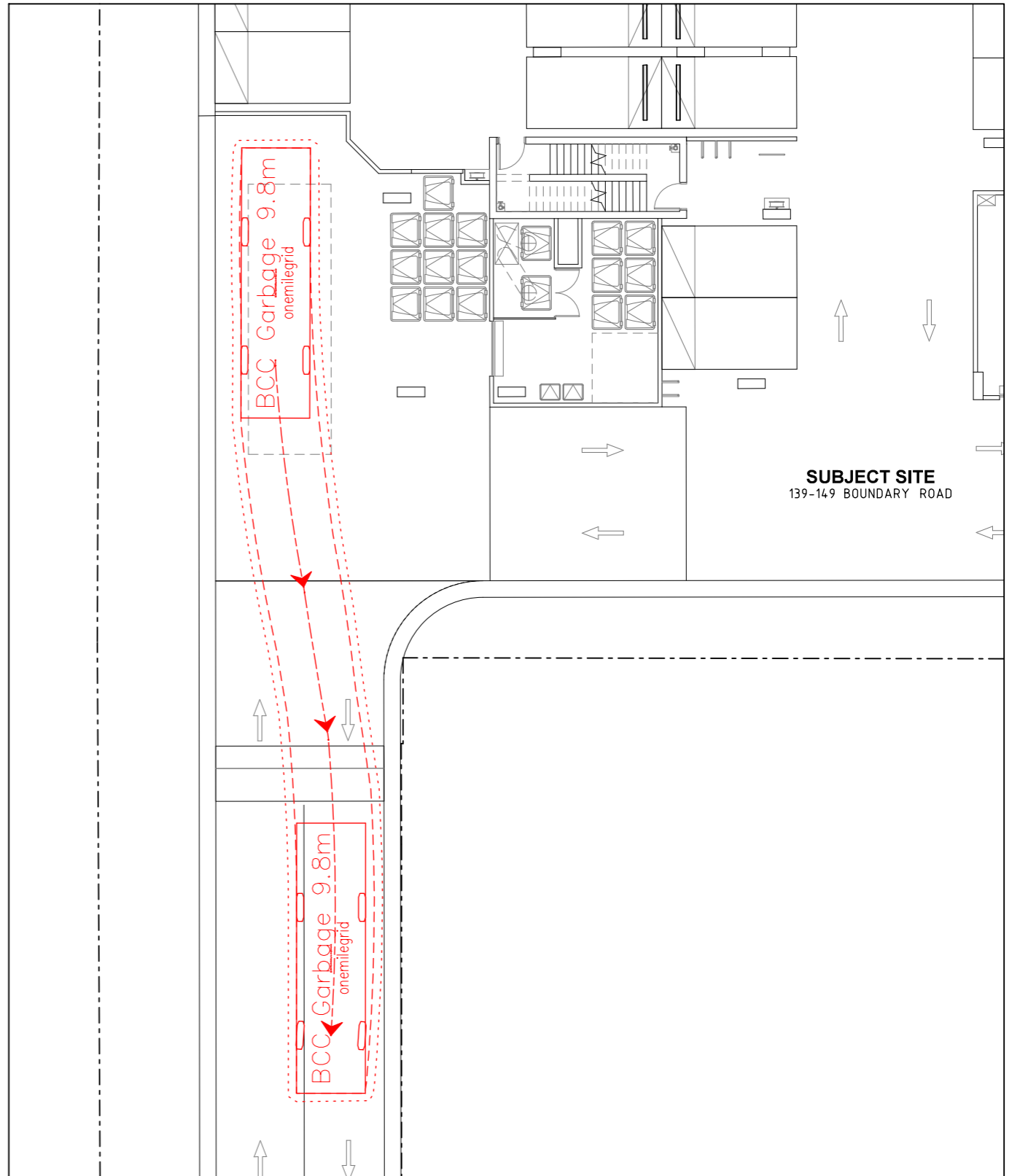
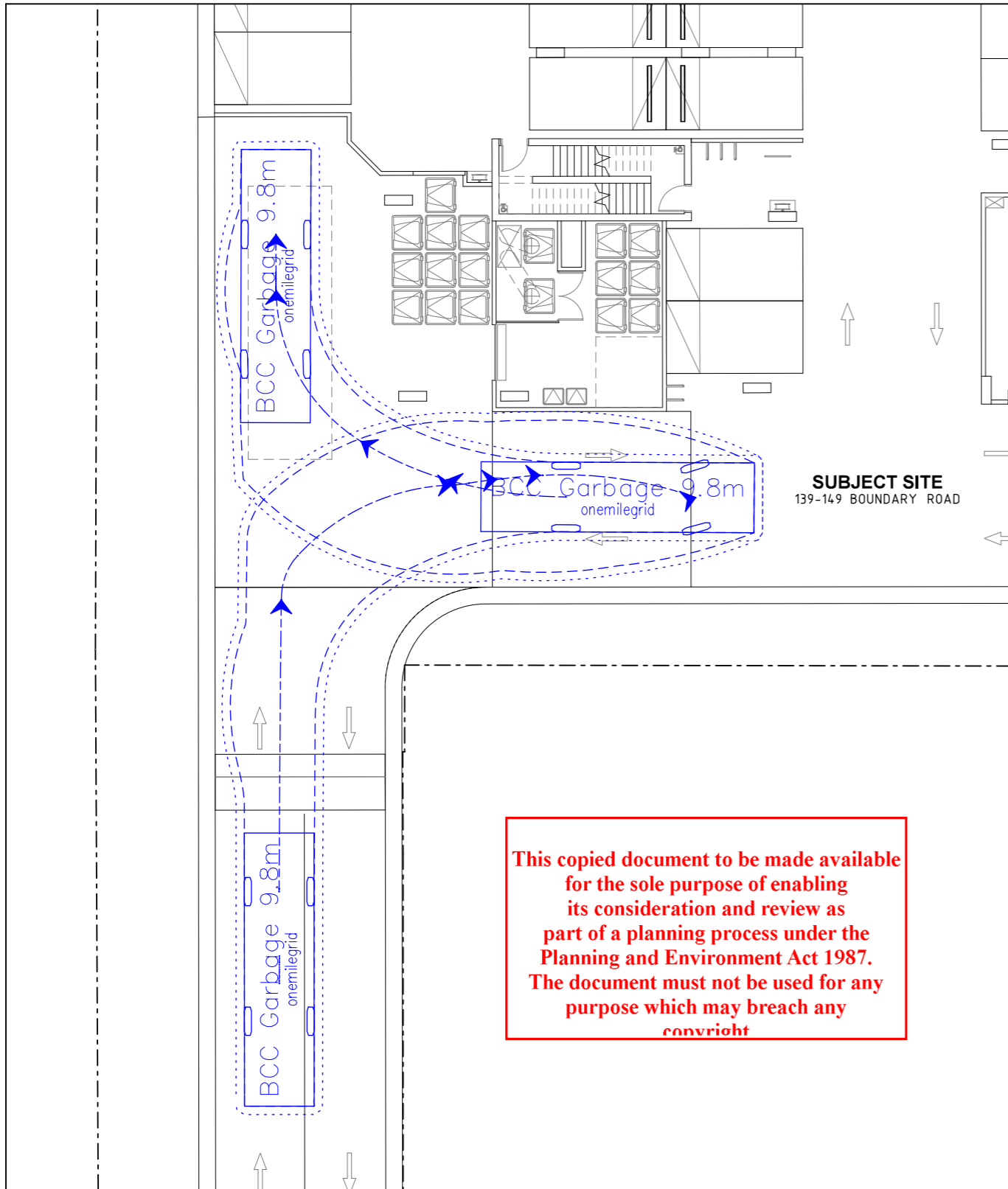

ENTRY MANOEUVRES

----- DESIGN VEHICLE SWEEP PATHS SHOWN DASHED
..... 300mm CLEARANCE ENVELOPE SHOWN DOTTED

EXIT MANOEUVRES

----- DESIGN VEHICLE SWEEP PATHS SHOWN DASHED
..... 300mm CLEARANCE ENVELOPE SHOWN DOTTED

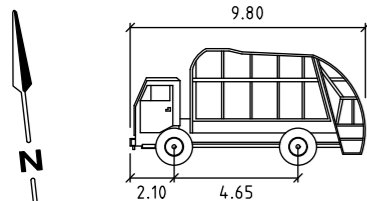

BCC GARBAGE 9.8m meters

Width	: 2.50
Track	: 2.50
Lock to Lock Time	: 4.0
Steering Angle	: 35.8

ADVERTISED PLAN



Drawing Title
**139-149 BOUNDARY RD, NORTH MELBOURNE
 WASTE VEHICLE BASEMENT ACCESS
 SWEEP PATH ANALYSIS**

Designed RG	Approved JD	Metway Ref 43 B11
----------------	----------------	----------------------

Scale
1:200 @ A3

Project Number 190608	Drawing Number SPA101	Revision E
--------------------------	--------------------------	---------------

ADVERTISED PLAN

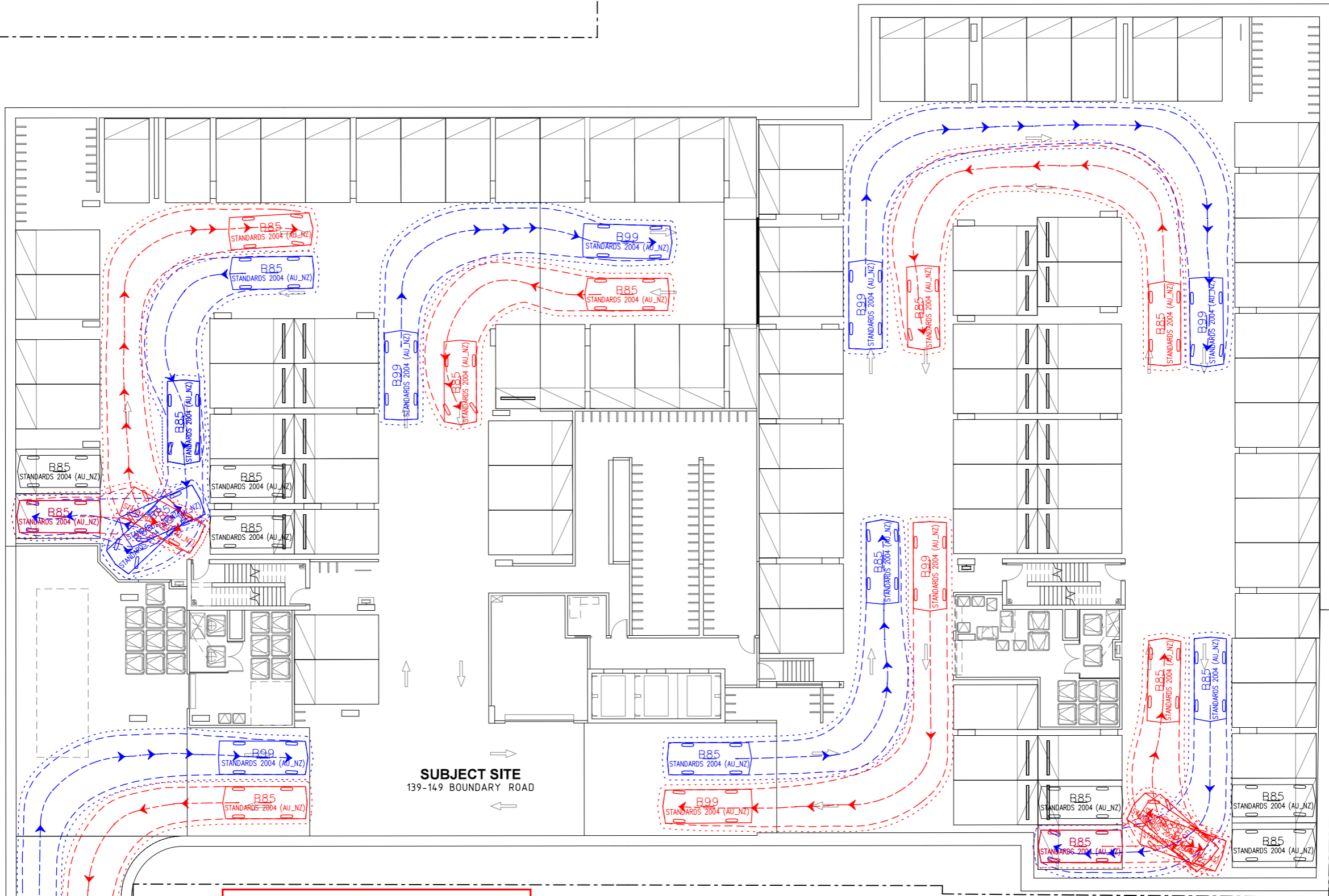

SUBJECT SITE
139-149 BOUNDARY ROAD

This copied document to be made available for the sole purpose of enabling its consideration and review as part of a planning process under the Planning and Environment Act 1987. The document must not be used for any purpose which may breach any copyright

SWEPT PATH LEGEND

- DESIGN VEHICLE SWEPT PATHS SHOWN DASHED
- 300mm CLEARANCE ENVELOPE SHOWN DOTTED

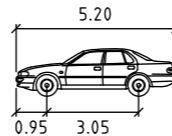

B99
Width : 1.94
Track : 1.84
Lock to Lock Time : 6.0
Steering Angle : 33.9

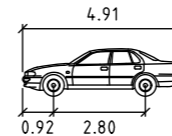

B85
Width : 1.87
Track : 1.77
Lock to Lock Time : 6.0
Steering Angle : 34.1



Scale: 1:250 @ A3

Drawing Title
139-149 BOUNDARY RD, NORTH MELBOURNE
BASEMENT - VEHICLE SITE ACCESS
SWEPT PATH ANALYSIS

Designed RG	Approved JD	Metway Ref 43 B11
Project Number 190608	Drawing Number SPA102	Revision D

ADVERTISED PLAN

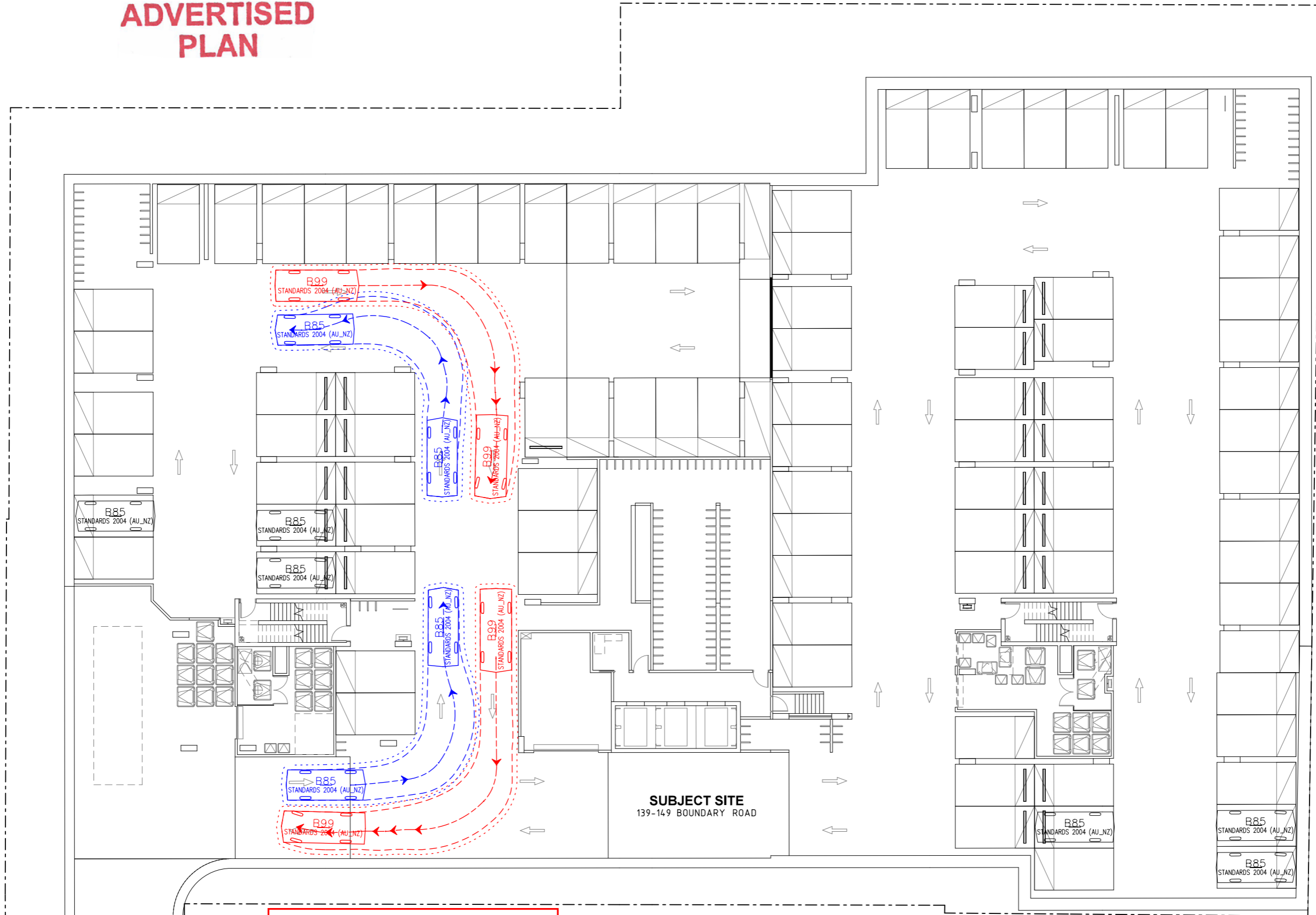

This copied document to be made available for the sole purpose of enabling its consideration and review as part of a planning process under the Planning and Environment Act 1987. The document must not be used for any purpose which may breach any copyright

SWEPT PATH LEGEND

- DESIGN VEHICLE SWEEP PATHS SHOWN DASHED
- 300mm CLEARANCE ENVELOPE SHOWN DOTTED

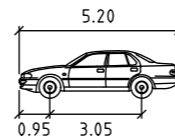

B99
 Width : 1.94
 Track : 1.84
 Lock to Lock Time : 6.0
 Steering Angle : 33.9

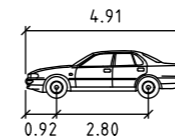

B85
 Width : 1.87
 Track : 1.77
 Lock to Lock Time : 6.0
 Steering Angle : 34.1



Scale: 1:250 @ A3
 0 1.25 2.5 5 meters

Drawing Title
**139-149 BOUNDARY RD, NORTH MELBOURNE
 BASEMENT - VEHICLE SITE ACCESS
 SWEEP PATH ANALYSIS**

Designed RG	Approved JD	Metway Ref 43 B11
----------------	----------------	----------------------

Project Number 190608	Drawing Number SPA103	Revision D
--------------------------	--------------------------	---------------

ADVERTISED PLAN

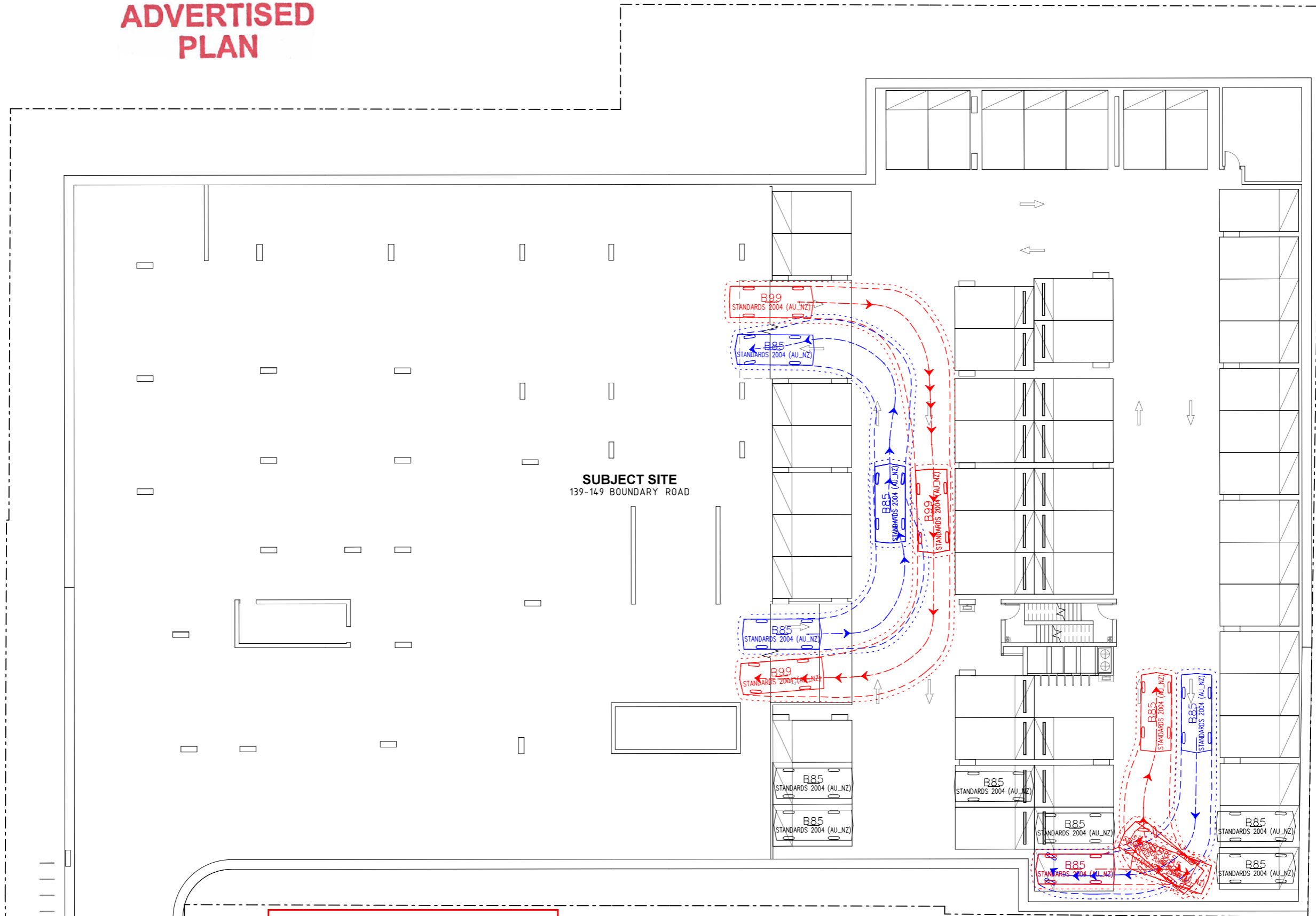

SUBJECT SITE
139-149 BOUNDARY ROAD

This copied document to be made available for the sole purpose of enabling its consideration and review as part of a planning process under the Planning and Environment Act 1987. The document must not be used for any purpose which may breach any copyright

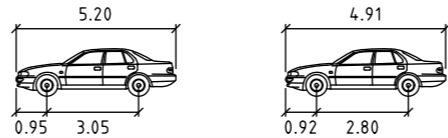

B99		B85	
	meters		meters
Width	: 1.94	Width	: 1.87
Track	: 1.84	Track	: 1.77
Lock to Lock Time	: 6.0	Lock to Lock Time	: 6.0
Steering Angle	: 33.9	Steering Angle	: 34.1

SWEPT PATH LEGEND

- DESIGN VEHICLE SWEEP PATHS SHOWN DASHED
- 300mm CLEARANCE ENVELOPE SHOWN DOTTED

56 Down Street, Collingwood, VIC 3066
 Email: info@onemilegrid.com.au Web: www.onemilegrid.com.au
 Phone (03) 9939 8250

Scale: 1:250 @ A3
 0 1.25 2.5 5

Drawing Title
139-149 BOUNDARY RD, NORTH MELBOURNE
LOWER GROUND - VEHICLE SITE ACCESS
SWEPT PATH ANALYSIS

Designed RG	Approved JD	Metway Ref 43 B11
----------------	----------------	----------------------

Project Number 190608	Drawing Number SPA104	Revision D
--------------------------	--------------------------	---------------

ADVERTISED PLAN

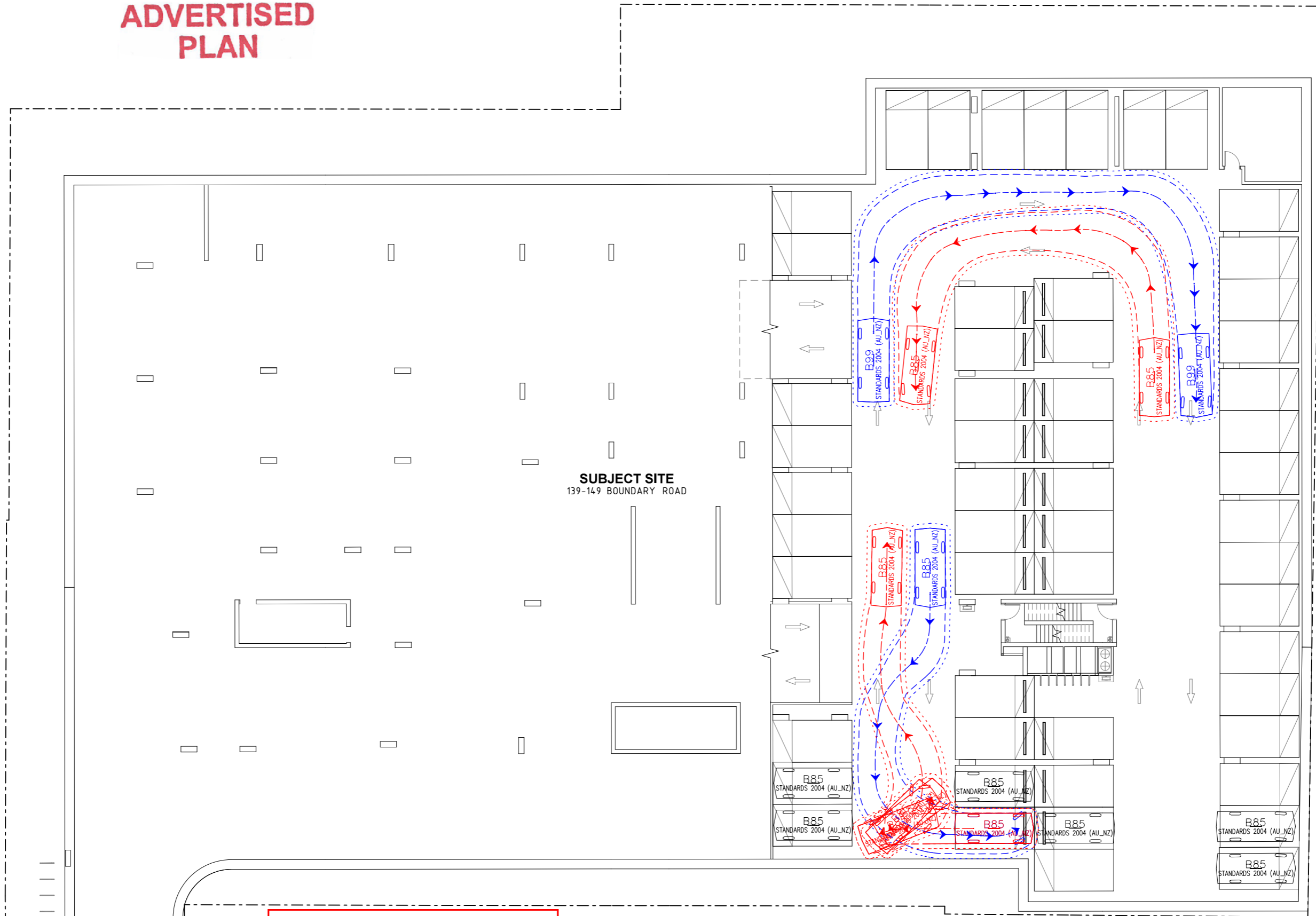

SUBJECT SITE
139-149 BOUNDARY ROAD

This copied document to be made available for the sole purpose of enabling its consideration and review as part of a planning process under the Planning and Environment Act 1987. The document must not be used for any purpose which may breach any copyright

SWEPT PATH LEGEND

- DESIGN VEHICLE SWEEP PATHS SHOWN DASHED
- 300mm CLEARANCE ENVELOPE SHOWN DOTTED

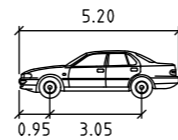

B99
Width : 1.94
Track : 1.84
Lock to Lock Time : 6.0
Steering Angle : 33.9

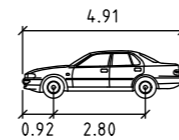

B85
Width : 1.87
Track : 1.77
Lock to Lock Time : 6.0
Steering Angle : 34.1

56 Down Street, Collingwood, VIC 3066
Email: info@onemilegrid.com.au Web: www.onemilegrid.com.au
Phone (03) 9939 8250

Scale: 1:250 @ A3
0 1.25 2.5 5

Drawing Title
139-149 BOUNDARY RD, NORTH MELBOURNE
LOWER GROUND - VEHICLE SITE ACCESS
SWEPT PATH ANALYSIS

Designed RG	Approved JD	Metway Ref 43 B11
----------------	----------------	----------------------

Project Number 190608	Drawing Number SPA105	Revision D
--------------------------	--------------------------	---------------

ADVERTISED PLAN



SUBJECT SITE
139-149 BOUNDARY ROAD

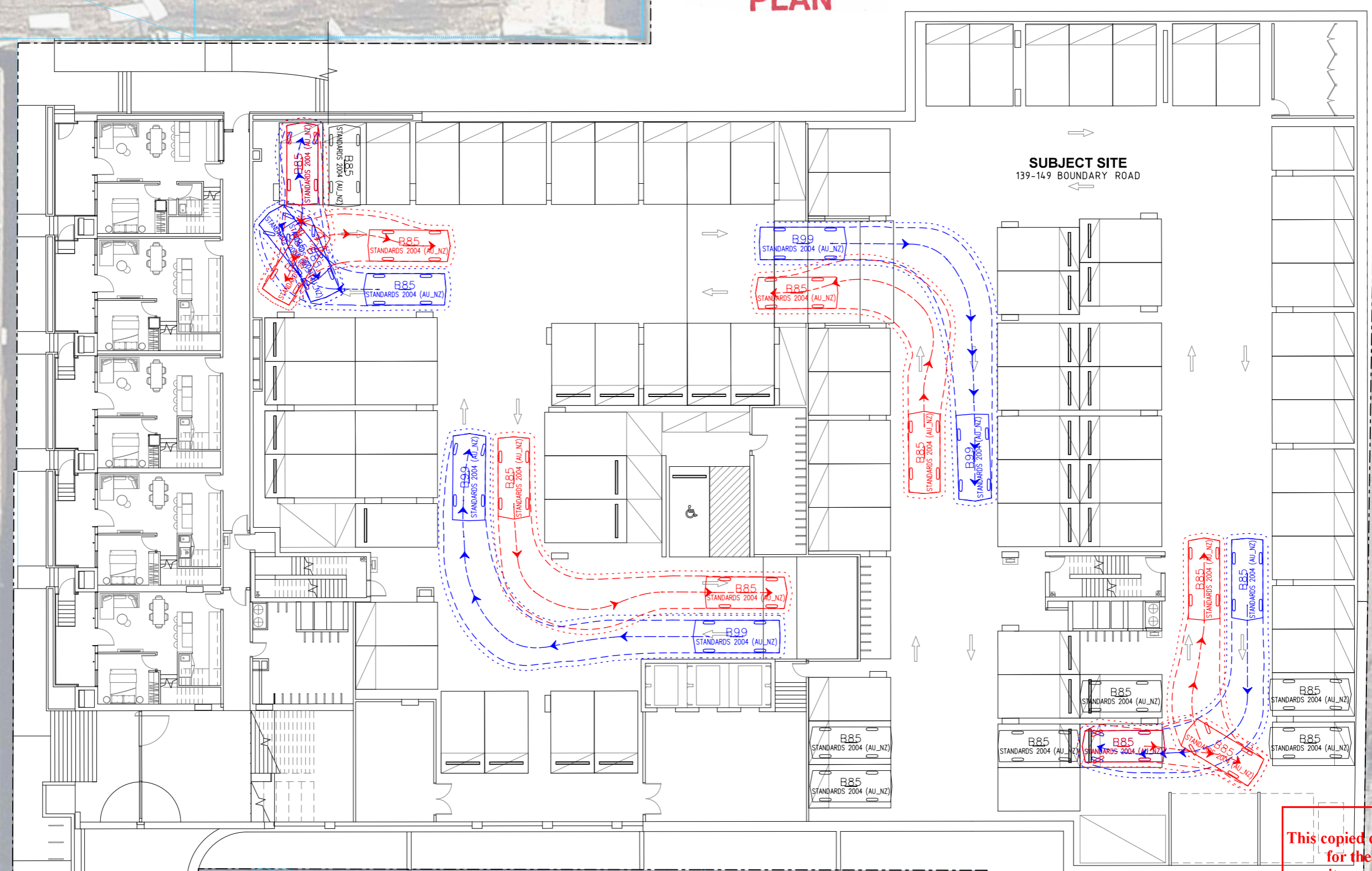

This copied document to be made available for the sole purpose of enabling its consideration and review as part of a planning process under the Planning and Environment Act 1987. The document must not be used for any purpose which may breach any copyright

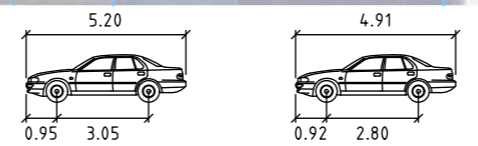

SWEPT PATH LEGEND
 - - - - - DESIGN VEHICLE SWEEP PATHS SHOWN DASHED
 ······ 300mm CLEARANCE ENVELOPE SHOWN DOTTED

	B99	meters	B85	meters
Width	: 1.94		: 1.87	
Track	: 1.84		: 1.77	
Lock to Lock Time	: 6.0		: 6.0	
Steering Angle	: 33.9		: 34.1	

onemilegrid
TRAFFIC ENGINEERING
 56 Down Street, Collingwood, VIC 3066
 Email: info@onemilegrid.com.au Web: www.onemilegrid.com.au
 Phone (03) 9939 8250

Scale: 1:250 @ A3

Drawing Title 139-149 BOUNDARY RD, NORTH MELBOURNE GROUND - VEHICLE SITE ACCESS SWEPT PATH ANALYSIS		
Designed RG	Approved JD	Metway Ref 43 B11
Project Number 190608	Drawing Number SPA106	Revision C

CAD File: N:\Projects\2019\190608\Drawings\190608SPA106.dgn

Date Plotted: 23-09-2021 5:07:48 PM

Copyright
This document may only be used for its commissioned purpose. No part of this document may be reproduced, modified or transmitted without the written authority of onemilegrid. Unauthorised use of this document in any form is prohibited.

ADVERTISED PLAN

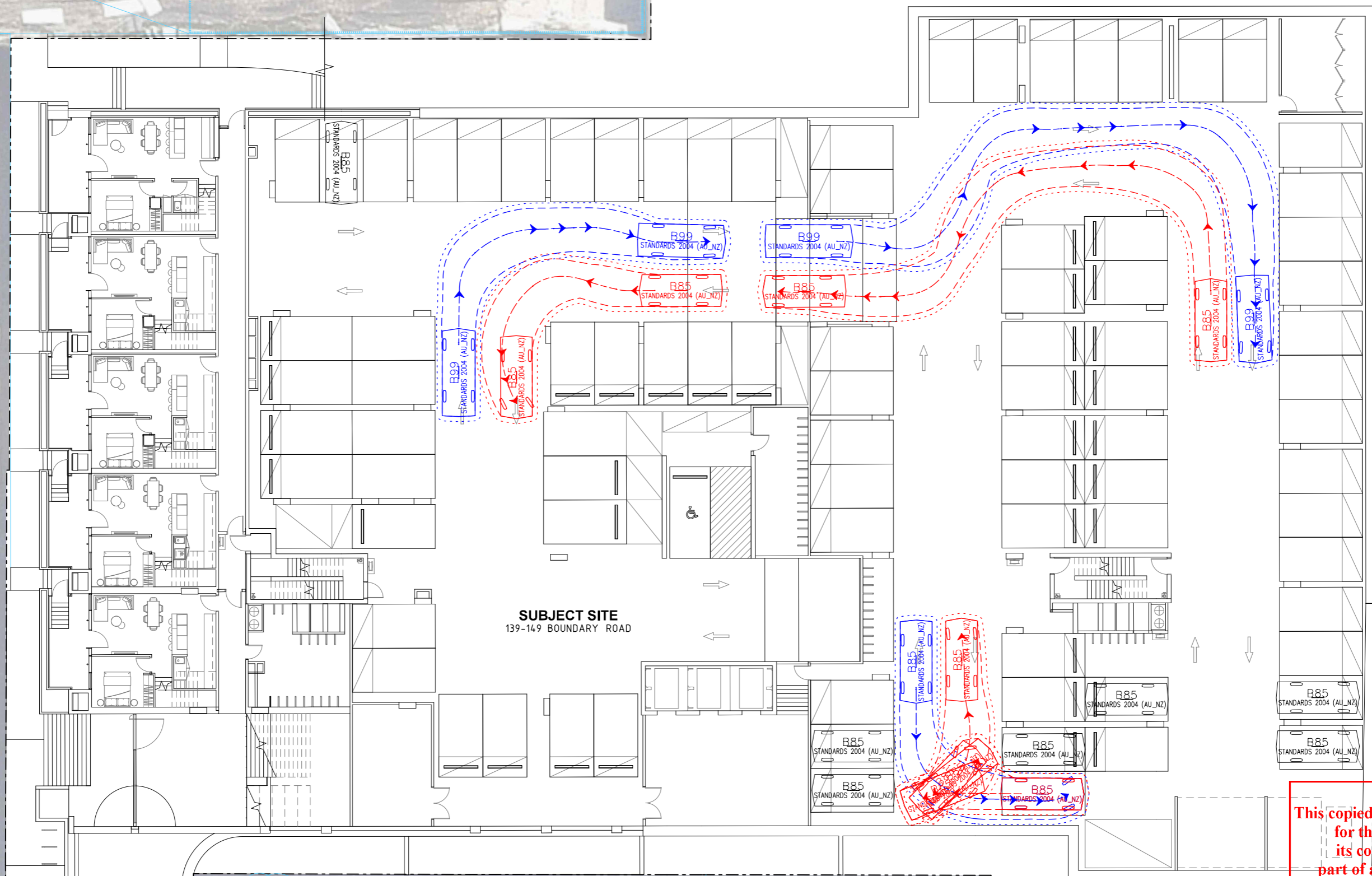
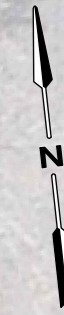

SUBJECT SITE
139-149 BOUNDARY ROAD

This copied document to be made available for the sole purpose of enabling its consideration and review as part of a planning process under the Planning and Environment Act 1987. The document must not be used for any purpose which may breach any copyright

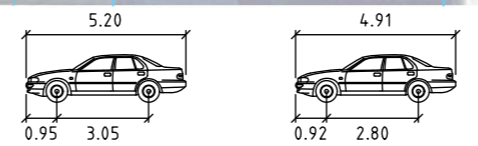

SWEPT PATH LEGEND

- DESIGN VEHICLE SWEEP PATHS SHOWN DASHED
- 300mm CLEARANCE ENVELOPE SHOWN DOTTED

Vehicle	Width (meters)	Track (meters)	Lock to Lock Time	Steering Angle
B99	1.94	1.84	6.0	33.9
B85	1.87	1.77	6.0	34.1



56 Down Street, Collingwood, VIC 3066
 Email: info@onemilegrid.com.au Web: www.onemilegrid.com.au
 Phone (03) 9939 8250

Drawing Title
 139-149 BOUNDARY RD, NORTH MELBOURNE
 GROUND - VEHICLE SITE ACCESS
 SWEEP PATH ANALYSIS

Designed RG	Approved JD	Metway Ref 43 B11
----------------	----------------	----------------------

Project Number 190608	Drawing Number SPA107	Revision C
--------------------------	--------------------------	---------------

Scale
 1:250 @ A3

CAD File: N:\Projects\2019\190608\Drawings\190608SPA107.dgn

Date Plotted: 23-09-2021 5:08:15 PM