

Powercor Australia

Proposed Powercor Terminal Station - Lot 4, 1005 Boundary Road, Tarneit

Preliminary Flood Risk Assessment

February 2026

Public



Question today Imagine tomorrow Create for the future



Proposed Powercor Terminal Station - Lot 4, 1005 Boundary Road, Tarneit Preliminary Flood Risk Assessment

Powercor Australia

WSP
Level 11, 567 Collins St
Melbourne VIC 3000

Tel: +61 3 9861 1111
Fax: +61 3 9861 1144
wsp.com

Rev	Date	Details
A	18/02/2026	For Issue

	Name	Date	Signature
Prepared by:	MC	11/02/2026	
Reviewed by:	JB	17/02/2026	
Approved by:	KS	18/02/2026	

WSP acknowledges that every project we work on takes place on First Peoples lands.
We recognise Aboriginal and Torres Strait Islander Peoples as the first scientists and engineers and pay our respects to Elders past and present.

This document may contain confidential and legally privileged information, neither of which are intended to be waived, and must be used only for its intended purpose. Any unauthorised copying, dissemination or use in any form or by any means other than by the addressee, is strictly prohibited. If you have received this document in error or by any means other than as authorised addressee, please notify us immediately and we will arrange for its return to us.



Table of contents

	Abbreviations	iii
	Executive summary	iv
1	Introduction	1
1.1	Project Background	1
1.2	Study Area and Catchment Context	2
1.3	Site Description and Drainage Context	2
1.4	Previous Studies and Planning Context	2
1.5	Available Data and Information Sources	2
1.6	Report Structure	3
2	Objectives	4
3	Methodology and Assumptions	5
3.1	Catchment Characteristics	5
3.2	Flood Modelling Approach	5
3.2.1	Assessment Philosophy	5
3.2.2	Hydrologic Modelling (RORB)	5
3.2.3	Hydraulic Modelling (TUFLOW)	7
3.3	Climate Change Assessment	8
3.4	Key Assumptions and Limitations	8
4	Stormwater Management Framework	9
4.1	Existing Drainage Conditions	9
4.2	Melbourne Water Drainage Scheme Context	9
4.2.1	Development Services Scheme	9
4.2.2	Truganina DSS	10
4.3	Legal Point of Discharge and Internal Drainage Strategy	11
4.4	Finished Surface Levels	12
4.5	Stormwater Quality Considerations	12
5	Flood Risk Assessment	13
5.1	Flood Events Assessed	13
5.2	Flood Extent and Depth	13
5.2.1	Existing conditions	13



5.2.2 Developed Conditions 15

5.3 Peak Flows and Flow Paths15

5.3.1 Existing Conditions 15

5.3.2 Developed Conditions..... 15

5.4 Flood Hazard16

5.5 Bench Level Assessment.....16

5.6 Site Access and Flood Safety16

6 Conclusions 17

7 Limitations 18

Abbreviations

AEP	Annual Exceedance Probability
ARR	Australian Rainfall and Runoff
DSS	Drainage Service Scheme
MW	Melbourne Water
RB	Retarding Basin
RORB	Runoff Routing Over Basins
SSP	Shared Socioeconomic Pathway
TLH	Tarneit Logistics Hub
TUFLOW	Two-Dimensional Unsteady Flow
WCC	Wyndham City Council
WL	Wetland

Executive summary

This report presents a flood and stormwater assessment for the proposed development at **1005 Boundary Road, Tarneit**, located within the Tarneit Logistics Hub (TLH) precinct and governed by the **Melbourne Water Truganina Drainage Services Scheme (DSS)**.

The assessment was undertaken to define existing flood behaviour, confirm ultimate drainage conditions following implementation of the revised DSS infrastructure, and demonstrate that the development can be safely serviced without adverse flood impacts.

Historically, the site formed part of a broad overland flow corridor draining toward Dry Creek, receiving shallow regional sheet flow from approximately 188 hectares of upstream catchment within a total contributing catchment of approximately 4,060 hectares. Modelled existing conditions confirm that flood depths across the site are shallow (generally <50 mm in the 'baseline' 1% AEP event) and characterised by diffuse overland flow rather than defined flooding. Although not hazardous, these flows represent external catchment runoff that would constrain development in the absence of formal drainage infrastructure.

Integration into the amended Melbourne Water Truganina DSS has been detailed in the *Tarneit Logistic Hub-Stormwater Drainage Strategy* (DCE, October 2025). The strategy was endorsed by Wyndham City Council on 11 November 2025.

The amended DSS fundamentally changes the hydraulic behaviour of the local catchment area. A regional retarding basin and wetland north of Boundary Road will now intercept all upstream catchment runoff before it reaches the site. Flows are conveyed through a 1200 mm trunk drainage pipe within the TLH road reserve to downstream DSS wetlands and basins.

Staged delivery of the DSS assets will coincide with the staged construction of the TLH and upgrade of Boundary Road. As a result, the site will no longer function as part of a regional floodplain and instead operate as an internally drained parcel connected directly to formal drainage infrastructure.

A coupled hydrologic (RORB) and hydraulic (TUFLOW) modelling approach was adopted consistent with Melbourne Water guidelines and ARR version 4.2 procedures, including climate change scenarios (SSP3-7.0 2030 and 2070 horizons). The modelling confirms that, under ultimate DSS conditions, external flooding and overland flow paths do not interact with the site.

The proposed drainage strategy directs runoff generated within the site to the regional system as follows:

- Minor flows up to the 10% AEP event will discharge to the TLH underground drainage network and downstream DSS wetland and retarding basin
- Major flows up to the 1% AEP event will discharge via overland flow to the Melbourne Water easement along the eastern boundary and into the same DSS basin system

Water quality treatment and flow attenuation are provided regionally within the DSS wetlands and retarding basins. Accordingly, no onsite stormwater detention or treatment infrastructure is required, and the development will contribute via Melbourne Water DSS levies.

The current residential contribution rates are \$174,169 /Ha, comprising of a:

- hydraulic levy of \$102,371 /Ha, and

- stormwater quality levy of \$71,798/Ha

The assessment demonstrates that once the DSS infrastructure is delivered:

- The site will not be subject to flooding
- The development will not increase flood risk elsewhere
- Safe access will be maintained during the 1% AEP event including climate change
- The proposal complies with Melbourne Water drainage servicing intent

The proposed development is therefore considered acceptable from a flooding and stormwater management perspective and suitable for planning approval subject to detailed design.

1 Introduction

The purpose of this report is to define the flood risk and stormwater management for the proposed development of Lot 4 of 1005 Boundary Road by Powercor (hereafter referred to as the Site). Powercor is proposing to build a new terminal station on the Site (refer Figure 1-1).

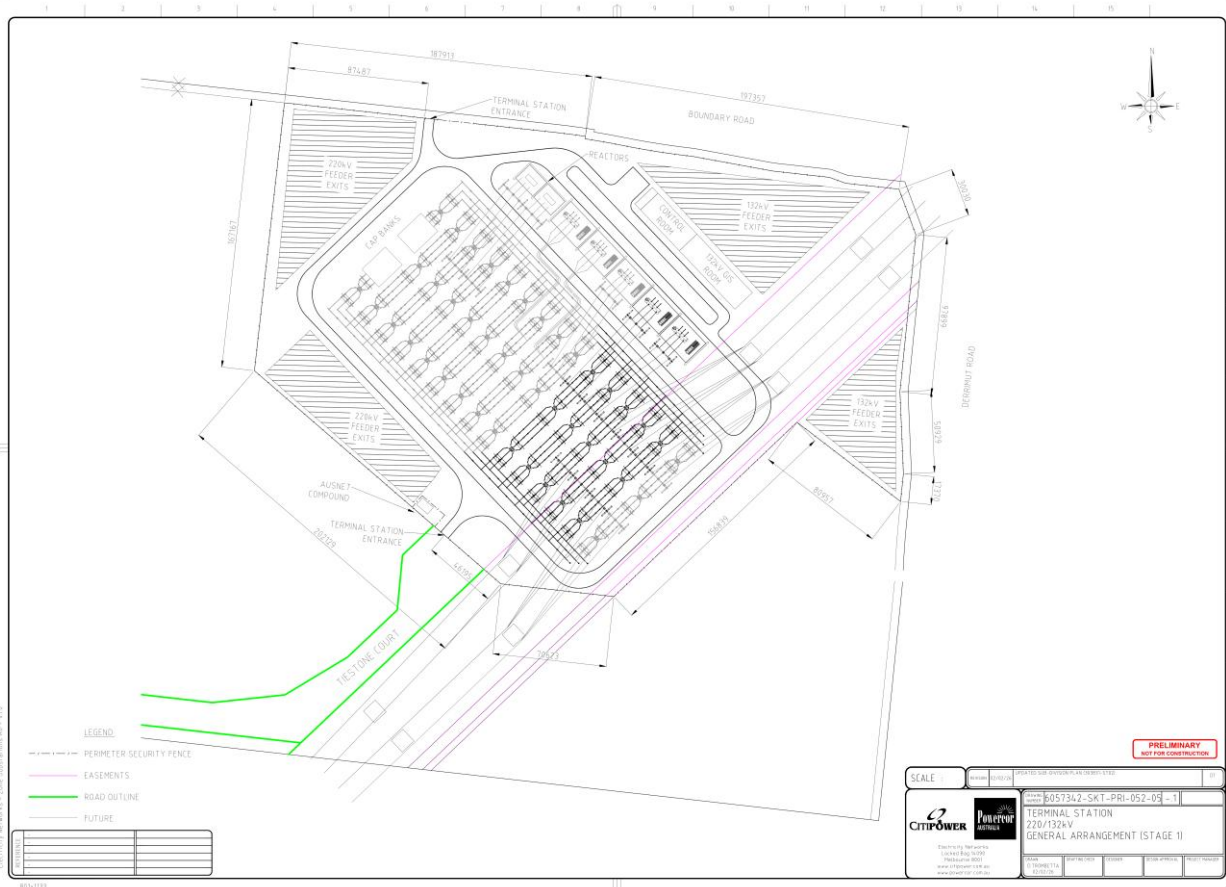

Figure 1-1 Preliminary terminal station layout (2 Feb 2026)

1.1 Project Background

The proposed development at 1005 Boundary Road, Tarneit forms part of the broader Tarneit Logistics Hub (TLH) precinct within the area governed by the Melbourne Water Truganina Drainage Services Scheme (DSS). The precinct is undergoing staged urbanisation transitioning from rural land to an employment and logistics land use consistent with the relevant planning framework and approved precinct structure planning. As part of this transition, regional drainage and water quality management is being delivered through formalised Melbourne Water infrastructure including retarding basins, constructed wetlands and trunk conveyance infrastructure designed to intercept and manage upstream catchment runoff prior to discharge to downstream waterways.

The DSS has recently been revised to incorporate a regional basin and wetland system north of Boundary Road which captures all upstream catchment flows before they reach the Site. Treated flows are conveyed

via a 1200 mm trunk drainage pipe located within the TLH main road reserve to a downstream DSS basin and wetland system south of the Site. Consequently, the Site is no longer subject to uncontrolled external catchment runoff under ultimate conditions.

The development therefore interfaces directly with a functioning regional drainage network where flood conveyance and water quality treatment are managed at a catchment scale rather than a lot-scale. The role of the Site drainage is limited to collection and discharge of locally generated runoff into the formalised DSS infrastructure.

1.2 Study Area and Catchment Context

The study area includes the local catchments draining toward the Site and the downstream reaches of Dry Creek. The contributing Dry Creek catchment area at the Site is approximately 4,060 hectares, with a local sub-catchment of approximately 188 hectares draining directly toward the Site from the north.

1.3 Site Description and Drainage Context

The Site is a 8.93 hectare land parcel located within the Wyndham growth corridor in an area transitioning from rural land to urban industrial development. The broader catchment historically drained toward a tributary of Dry Creek via shallow undefined overland flow paths across relatively flat terrain. Prior to implementation of the updated drainage scheme, regional runoff from upstream land parcels would have crossed the Site as shallow sheet flow mostly less than 50 mm in depth.

The revised Melbourne Water drainage strategy fundamentally changes the hydrologic behaviour of the area by intercepting upstream flows prior to reaching the Site. The upstream retarding basin north of Boundary Road captures and attenuates all catchment runoff external to the development parcel. Conveyance through the TLH road reserve trunk system prevents uncontrolled overland flow paths from entering individual lots.

Consequently, the Site functions hydrologically as an internally drained urban parcel connected directly to formal drainage infrastructure rather than part of a regional flow corridor.

1.4 Previous Studies and Planning Context

Relevant planning and flood management documents include the Wyndham Flood Management Plan (2018) and the, recently amended, Melbourne Water Truganina Drainage Scheme. These documents indicate that while regional flooding does not directly affect the Site, management of local overland flows and integration with planned regional drainage infrastructure are critical considerations.

1.5 Referenced Data and Report Documentation

The assessment referenced information provided by Powercor and publicly available datasets, including:

- 1 Verdent Hill Neighbourhood 2 and 5 – Stormwater Management Strategy (Spiire, October 2025)
- 2 Endorsed Tarneit Logistic Hub- Stormwater Drainage Strategy (DCE, October 2025)
- 3 Detailed topographic survey of the Site (Spiire, September 2025)

- 4 Construction Issue Civil Drawings External Watermain (DCE, 23 September 2025)
 - 5 Concept layout of the proposed terminal station
 - 6 Concept development plans for the Tarneit Logistics Hub
 - 7 Publicly available LiDAR from the ELVIS Elevation and Depth Foundation Spatial Data website
 - 8 Design rainfall and hydrologic parameters from the ARR Data Hub
 - 9 Bureau of Meteorology design rainfall data
 - 10 Wyndham Flood Management Plan (2018)
 - 11 Melbourne Water Truganina Drainage Scheme **Amended by reference 1*
-

1.6 Report Structure

The following report describes the objectives of the study, the methodology and assumptions adopted, the stormwater and flood risk assessment outcomes, water quality considerations, and the conclusions and recommendations arising from the assessment.

2 Objectives

The objectives of this assessment are to:

- Develop a baseline flood model representing existing conditions at and upstream of the Site prior to DSS implementation
- Assess flood behaviour for the 20% and 1% AEP events incorporating climate change
- Define a compliant site drainage strategy consistent with Melbourne Water servicing intent
- Quantify and confirm how minor and major system flows generated within the Site will be conveyed to the DSS assets
- Confirm that water quality treatment will be provided regionally within the DSS infrastructure and that onsite treatment is not required.

3 Methodology and Assumptions

3.1 Catchment Characteristics

The Site is located within the Wyndham LGA and is zoned for urban growth. The surrounding land use is predominantly rural with emerging urban development along the northern and southern boundaries of the catchment. There are no major storages within the contributing catchments.

3.2 Flood Modelling Approach

A coupled hydrologic and hydraulic modelling framework was adopted to assess flood behaviour at and around the Site, consistent with Melbourne Water Flood Mapping Guidelines.

3.2.1 Assessment Philosophy

The modelling approach was undertaken in two stages. First, existing conditions flood behaviour was established to understand the natural flow regime and confirm the magnitude of regional runoff historically affecting the Site. Second, ultimate conditions were assessed with consideration of the revised drainage scheme, as documented in *Spiire 2020* and *DCE 2025*, and regrading of the Boundary Road and Derrimut Road intersection resulting in the redirection of external flows away from the site.

3.2.2 Hydrologic Modelling (RORB)

Hydrologic modelling was undertaken using RORB Version 6.45. Catchments and sub-catchments were delineated using publicly available LiDAR data, supplemented by the Site survey, urban drainage networks property boundaries, land uses and future development. The RORB model includes the Dry Creek catchment and the local catchment draining directly toward the Site.

Model parameters, including losses, routing parameters and impervious fractions, were adopted in accordance with ARR v4.2 guidance and planning scheme zoning. The model was run using the full ensemble of temporal patterns and storm durations ranging from 20 minutes to 18 hours to identify critical durations for key locations.

A summary of the key model parameters is provided in Table 3-1. The critical storm durations at key locations can be seen in Table 3-2.

Table 3-1 Key RORB model parameters

PARAMETER	INFORMATION
AEP's Assessed	20% and 1% AEP event with climate change
Durations and temporal patterns	A range of critical durations (20 minutes to 18 hours) and temporal patterns were identified for each AEP assessed, for 2 key locations - the Dry Creek and the local catchment upstream of the site. Critical storm durations were found to be between 12 hours for the dry creek and 90 minutes for the local catchment.
RORB Version	V6.45
Model Extent	Upper Dry Creek Catchment and Local Catchment

PARAMETER	INFORMATION
Number of sub-catchments	36
Total catchment area	4,060 ha
Typical sub-catchment area	100-400 ha (Dry Creek) 1.89-22.5 ha (Local)
Topographic data	10 m LiDAR
Rainfall	Frequent to rare IFD from Bureau of Meteorology website
Regional hydrologic parameters	Refer to Appendix A, downloaded from ARR Data Hub
Pre-burst	75 th percentile
Kc, m values	14.02, 0.8 (kc value based on RORB V6 User Manual Equation 2-5)
Initial and continuing loss (base)	IL 11 mm, CL 0.3 mm/h [Climate change adjustments factors detailed in Table 3-5]
Aerial reduction factor (ARF)	Based on full catchment area

Table 3-2 Critical durations and temporal patterns

LOCATION	CRITICAL DURATION AND TEMPORAL PATTERN			
	1%AEP (2030/2070)		20%AEP (2030/2070)	
Dry Creek	12-hour TP1	12-hour TP1	12-hour TP7	12-hour TP7
Local catchment	90minutes TP9	60minutes TP9	90minutes TP6	90minutes TP5

For the broader catchment, longer duration storms governed peak flow response due to storage attenuation and flat topography, whereas local runoff was driven by shorter duration high intensity rainfall.

Several different kc values were trialled to determine the appropriate value to adopt for the Tarneit hydrology study. For validation, the peak flow from the Toomuc Creek catchment at Pakenham was used for comparison. While Toomuc Creek is not in the direct vicinity of the Site, it is a similar size (4,200 ha) and land use and has a long record of stream flow data for calibration.

The 1%AEP flow for Toomuc Creek was estimated to be 42 m³/s, and the adopted kc value was 12. Based on this, a kc value of 14.02 was deemed to be the most appropriate for the Tarneit site. RORB Kc value sensitivity and peak flow validation can be seen in Table 3-3.

Table 3-3 Peak flow validation for Dry Creek

KC	BASIS	1%AEP RORB PEAK FLOW
14.02	RORB V6 User Manual Equation 2-5 (Adopted)	69
4.3	Pearse et al. (2002)	173
11	Based on Review of Laverton Creek Drainage Scheme Retarding Basins modelling*	83
12	Toomuc Creek**	42 (based on flood frequency analysis)

* Review of Laverton Creek Drainage Scheme Retarding Basins - Functional Design FINAL REPORT for Melbourne Water (Parsons Brinckerhoff, 2006); ** Benchmarking ARR2019 for Victoria – Technical Report (HARC, 2020)

Climate change rainfall adjustments consistent with ARR v4.2 SSP3-7.0 guidance were applied to ensure infrastructure suitability over the design life planning horizon. These factors increase rainfall intensity, temperature and losses but do not materially alter hydraulic behaviour due to the dominant influence of

controlled drainage infrastructure under ultimate conditions. The climate change scenarios are discussed further in Section 3.3.

3.2.3 Hydraulic Modelling (TUFLOW)

Two-dimensional hydraulic modelling was undertaken using TUFLOW HPC Version 2025.2.2. The model terrain was developed using a combination of LiDAR and detailed Site survey data. Localised smoothing was applied at dataset transitions to manage minor elevation discrepancies. The model includes Dry Creek and the overland flow paths traversing the Site.

Under existing conditions, upstream inflows were applied as distributed inflow boundaries representing catchment runoff. Under ultimate conditions, upstream inflows were removed and replaced by fixed infrastructure conveyance reflecting the upstream basin and trunk drainage system. This allows the model to directly represent the hydraulic environment the Site will experience once development infrastructure is in place.

Design surface models representing the Ultimate development within the TLH and DSS infrastructure has not yet been developed. Therefore, hydraulic modelling of the ultimate design is not yet possible and has not been included at this stage.

The model resolution and variable timestep were selected to ensure stable simulation of shallow sheet flows typical of low-gradient terrain. Sensitivity testing confirmed results were not dependent on grid size or timestep selection.

A summary of the key model parameters is provided in Table 3-4.

Table 3-4 Key TUFLOW model parameters

Parameter	Information
AEP's Assessed	20% and 1% AEP event with climate change (SSP3-7.0 2030 and 2070)
Durations and temporal patterns	Based on RORB model
Hydrologic Approach	Routed flows from RORB hydrological model
TUFLOW Version	2025.2.2-iSP-w64
Model Extent	Approximately 8 km ³ - covering the Local and upper Dry Creek catchments
Model Boundaries	2d BC inflows, 2d SA All regions and HQ outflow boundaries. For the defined creek lines 2d_BC inflows were applied and for the flat terrain upstream of the Site flows were applied as 2D_SA regions. The downstream boundary was based on a slope of 0.005
Grid Size	2 m grid
Topographic data	10 m LiDAR and detailed topographic survey for the site
Roughness	Spatially varying roughness values
Model Computational Timestep	Adaptive Timestep (HPC GPU)
Scenarios Modelled	Existing

3.3 Climate Change Assessment

Climate change adjustments were applied in accordance with ARR v4.2 guidance. The SSP3-7.0 scenario was adopted as representative of a conservative but reasonable future climate trajectory for critical infrastructure. Near-term (2030) and medium-term (2070) horizons were assessed as per recommended approach.

Rainfall intensity adjustment factors ranged from approximately 11–18% for 2030 conditions and 24–42% for 2070 conditions, depending on duration and AEP.

The Climate Change adjustment factors for the near-term and medium-term climate change scenarios under the SSP3-7.0 trajectory can be seen in Table 3-5.

Table 3-5: Climate Change Adjustment Factors (ARR Datahub)

Factor	SSP3-7.0 Near-Term (2030)	SSP3-7.0 Medium-Term (2070)
Rainfall (<1 hr – 12 hr duration)	1.18 – 1.11	1.42 – 1.24
Temperature	1.2	2.5
Initial Loss (Continuing Loss)	1.05 (1.1)	1.1 (1.23)

3.4 Key Assumptions and Limitations

The assessment relies on publicly available LiDAR data, which is relatively coarse. While comparison with site survey indicates reasonable agreement, more detailed survey of upstream areas is recommended at later design stages to refine flow estimates. The modelling represents existing conditions only and does not include future upstream development beyond that implied by current planning controls.

4 Stormwater Management Framework

4.1 Existing Drainage Conditions

Prior to implementation of the drainage scheme, existing drainage across the Site is characterised by shallow sheet flow and undefined overland flow paths. These flows are broad, slow moving and typically less than 100 mm deep during a 1% AEP event. Flood behaviour is governed by terrain gradients rather than channel conveyance, resulting in multiple diffuse flow paths rather than a defined watercourse.

Although depths are shallow, these flows represent regional catchment runoff and would impose constraints on development if unmanaged. Raising site levels without provision for conveyance would divert flows along the west boundary and or toward the road reserves.

The modelling confirmed that the Site historically functioned as part of a larger floodplain drainage corridor rather than an isolated parcel.

No formal drainage infrastructure currently exists within the Site, and some minor ponding (< 100 mm) is observed due to localised depressions within the modelled terrain. However, it is not expected that these provide or contribute to any effective floodplain storage.

4.2 Melbourne Water Drainage Scheme Context

4.2.1 Development Services Scheme

Melbourne Water utilises regional development services schemes (DSS) to “...plan the infrastructure required to ensure new urban development meets appropriate standards for flood protection, water quality, waterway health and amenity.”¹.

Melbourne Water’s DSS are “...designed to provide an integrated solution to drainage, waterway and stormwater quality works including:

- Adoption of an integrated catchment approach to stormwater management
- User based pricing, full cost recovery and removal of cross subsidies that are not consistent with efficient and effective services
- Environmental requirements based on the best available scientific information
- Protection of waterway health and biodiversity values.

The principles are designed to meet the tests of equity, transparency and nexus, while facilitating development in a way that leads to positive social, economic and environmental outcomes.”

The design standards for the DSS are guided by the following:

¹ Principles for Provision of Waterway and Drainage Services for Urban Growth ([Principles-for-provision-of-waterway-and-drainage-services-for-urban-growth.pdf](#))

- “All new developments will be provided with 1-in-100-year (AEP) flood protection consistent with ResCode requirement
- The minor drainage system shall have a capacity to cater for a 1-in-5-year (AEP) storm event
- Water quality treatment to ‘Best Practice’* (currently 45% reduction in total nitrogen and phosphorous, 80% reduction in total suspended solids)
- Protection of the environmental, social (including heritage) and economic values of waterways.”

4.2.2 Truganina DSS

The Site is located within the Melbourne Water Truganina DSS Drainage Scheme. The scheme identifies planned trunk drainage infrastructure and retarding basins downstream of the Site intended to manage regional runoff and protect downstream waterways.

The DSS underwent a detailed review and amendment by Spiire (2020) to improve functionality and feasibility and rectify inadequate assumptions and omissions in the original strategy developed by Engeny (2016).

The amended strategy can be seen relative to the original strategy in Figure 4-1 for the Dry Creek Upper DSS.

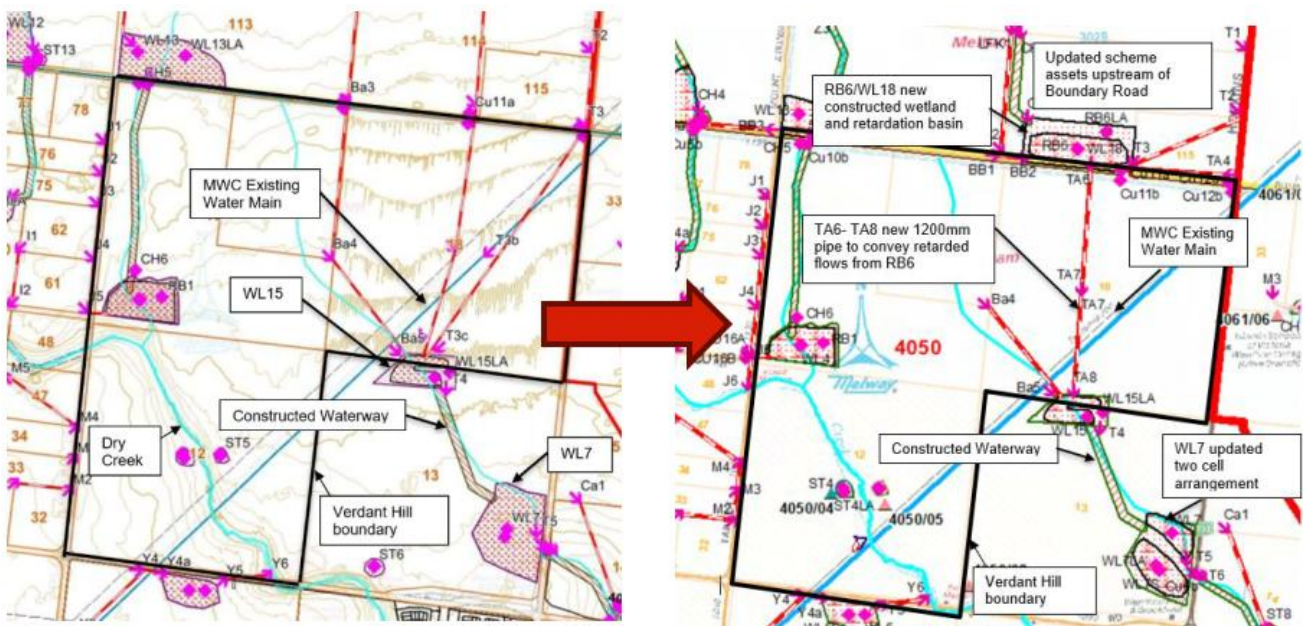

Figure 4-1: Dry Creek Upper DSS updates – Engeny 2016 (L) - Spiire 2020 (R)

Integration into the amended Melbourne Water Truganina DSS has been detailed in the *Tarneit Logistic Hub-Stormwater Drainage Strategy* (DCE, October 2025). The strategy was endorsed by Wyndham City Council on 11 November 2025. Section 2 of the DCE strategy details the timing of delivery of DSS assets and proof of cooperation with downstream development. This has been relied upon for this study.

Stormwater management for the Site will be governed by the updated Melbourne Water Drainage Scheme. The DSS provides regional flood detention, conveyance and water quality treatment infrastructure for the catchment area and defines the legal point of discharge for new development. The revised DSS assets can be seen in Figure 4-2 that will service upper Dry Creek and the TLH.

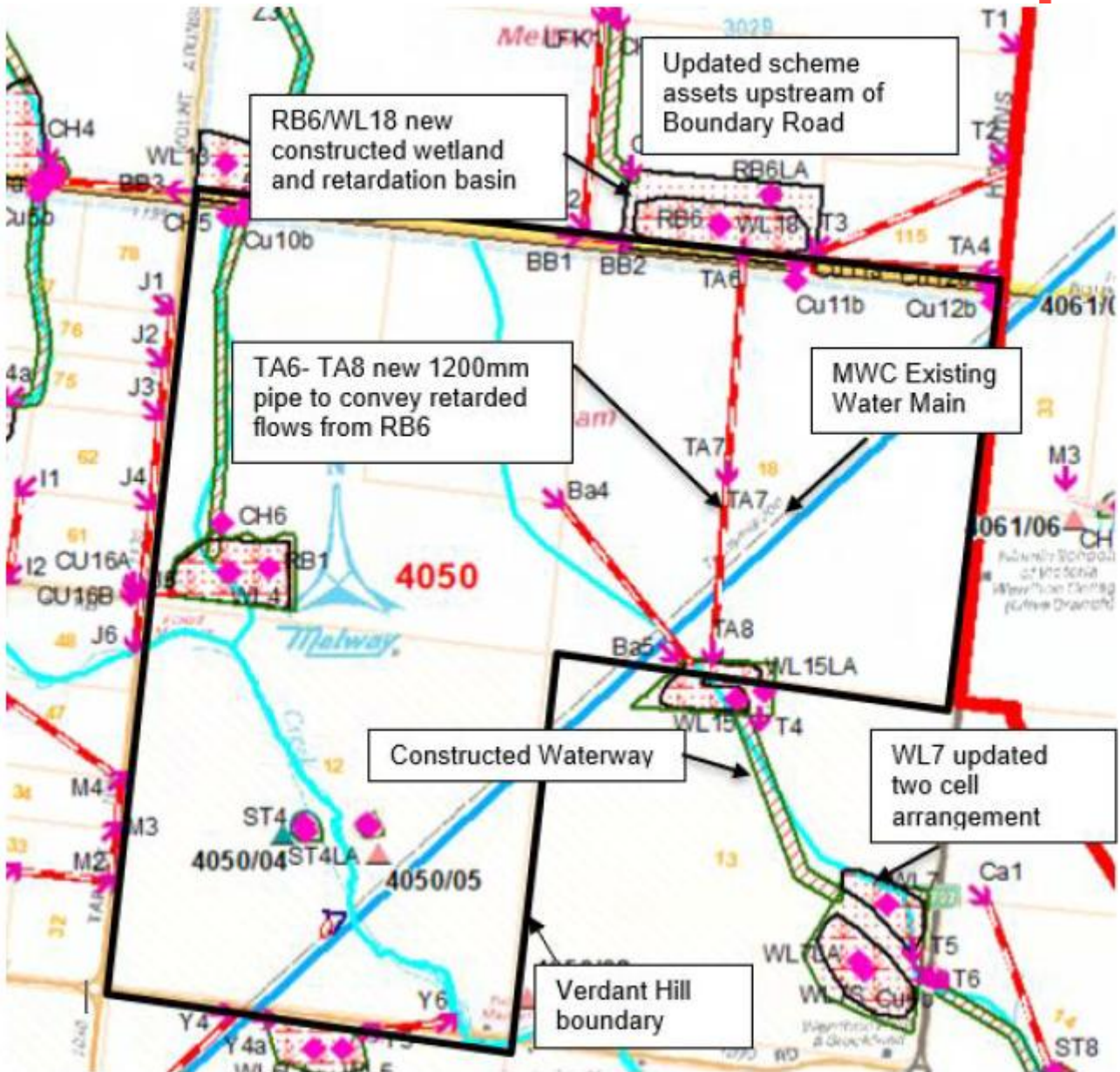

Figure 4-2: Dry Creek Upper DSS Overall Strategy (Spiire 2020)

4.3 Legal Point of Discharge and Internal Drainage Strategy

The ultimate legal point of discharge for the greater transit hub will be to Melbourne Water DSS infrastructure.

Two potential legal points of discharge have been identified for the terminal station site:

- Connection to the underground drainage network for flow up to and including the 10% AEP
- Discharge of gap flows up to and including the 1% AEP, with accommodation of the future near and medium-term climate change scenarios, to an open swale drain within the existing Melbourne Water and Ausnet easement at the south-east corner of the site.

4.4 Finished Surface Levels

Minimum finished levels should, typically, provide a minimum 300 mm freeboard above modelled design flood levels. Due to the absence of external flooding under the ultimate developed conditions, (largely delivered during Stage 1) required level increases will be modest and primarily ensure positive drainage toward the legal point of discharge.

4.5 Stormwater Quality Considerations

The site is located within the Tarneit Logistics Hub and connected to Melbourne Water DSS. Stormwater discharge generated within the frequent storm events will be discharged to the TLH drainage system and into the regional wetland (WL15) south of the site (Refer Appendix D).

It is noted (*DCE 2025*) that the delivery of the relevant DSS assets will be undertaken concurrently with the staged development of the TLH and Terminal Station. The endorsed *Tarneit Logistics Hub Stormwater Drainage Strategy (DCE, October 2025)* has accounted for the Terminal Station discharge.

An interim Stormwater Management Strategy has been developed for the TLH by Dalton Consulting Engineers (DCE) and endorsed by Wyndham City Council (11 November 2025) which will provide interim stormwater management in the event that - “...the construction of the downstream infrastructure is not complete, and Stage 1 is developed at the subject site.” - The Terminal Station is included in Stage 1 of the TLH development.

Due to these controls, no stormwater management (quality or quantity) is required for the Terminal Station.

5 Flood Risk Assessment

5.1 Flood Events Assessed

Flood behaviour was assessed for the 20% and 1% AEP events under SSP3-7.0 near-term 2030 and medium-term 2070 climate scenarios. The flood assessment has considered flood depths, peak flows, afflux and flood hazards. Detailed flood maps are provided in Appendix B.

5.2 Flood Extent and Depth

5.2.1 Existing conditions

Modelled results indicate that regional flooding from Dry Creek does not encroach onto the Site in events up to and including the modelled 1% AEP 2070 Climate Change scenario. Local overland flows, overtopping Boundary Road in the 2030 and 2070 1% AEP event, approach from the northwest corner and traverse along a broad undefined flow path in a south easterly direction across the site.

Flows overtopping Boundary Road near the Derrimut Road intersection are conveyed within a shallow swale drain which forms part of the Derrimut Road drainage. Modelling has shown that 1% AEP flows under base conditions (2030) and medium-term 2070 SSP3-7.0 climate change conditions exceed the capacity of the current swale drain and extend into the Site.

It is noted that the resolution of the LiDAR does not accurately capture the swale profile, resulting in an underestimation of the conveyance capacity. Flood extent within the site boundary can be considered conservative.

Runoff depths are shallow, generally less than 50 mm for the 1% AEP future medium-term (2070) climate change event – these are not considered flood depths but rather classified as shallow sheet flow. Flood depths traversing the site average < 60 mm and can reach 80 mm in small, localised depressions distributed within the site, during the 2030 and 2070 1% AEP events.

Note, no flooding is depicted within the site in the 2030 and 2070 20% AEP event scenarios.

Flood depths extending into the Site from the Derrimut Road drainage swale experience greater average depths, however, these do not exceed 150 mm in the 1% AEP event, and < 80 mm in the 20% AEP event.

The 1% AEP SSP3-7.0 near-term (2030) climate change horizon flood depth map can be seen in Figure 5-1, below. The 1% and 20% AEP flood depth mapping can be seen in Appendix B for the 'base-line' near-term (2030) and medium-term (2070) Climate Change scenarios under existing development conditions.



Trarke Hydrology Study
 SSP3-2030 1%AEP_CC
 Flood Depth

Legend

- Project Site
- Easement

SSP3-2030 1%AEP_CC Depth (m)

0.05 - 0.06
0.06 - 0.07
0.07 - 0.08
0.08 - 0.09
0.09 - 0.10
0.10 - 0.15
0.15 - 0.50
0.50 - 1.50
1.50 - 2.00

Coordinate System: GDA2020 MGA Zone 55
 1:6,700 Date: 18/02/2026
 Data sources: WSP, Google Earth (2016)

0 250 500 m

WSP

©WSP Australia Pty Ltd ("WSP") Copyright in the drawings, information and data recorded ("the information") is the property of WSP. This document and the information are solely for the use of the authorised recipient and this document may not be used, copied or reproduced in whole or part for any purpose other than that which it was supplied by WSP. WSP makes no representation, undertakes no duty and accepts no responsibility to any third party who may use or rely upon this document or the information. NCSI Certified Quality System to ISO 9001. ©
 APPROVED FOR AND ON BEHALF OF WSP Australia Pty Ltd.

WSP Victoria

Figure 5-1 Existing conditions flood depth (1%AEP SSP3-7.0-2030)

5.2.2 Developed Conditions

Under ultimate development conditions, all runoff generated within the upstream catchment north of Boundary Road will be intercepted and managed within the revised regional drainage infrastructure, specifically the RB6/WL18 retarding basin and wetland system. Captured flows will be conveyed via the trunk drainage network through the Tarneit Logistics Hub to downstream DSS assets, preventing uncontrolled overland flow from reaching the Site.

This outcome will be further reinforced by the reconstruction and regrading of Boundary Road and the Boundary Road–Derrimut Road intersection. These works form part of a major transport upgrade being delivered by Transport Victoria under the Big Build Roads program supporting the Tarneit Logistics Hub and surrounding growth area. The upgrade involves widening and raising sections of the road corridor, removing low points that historically allowed floodwater to overtop and traverse adjacent land. Completion of the intersection upgrade is currently scheduled for 2026. [\[Melton City Council\]](#) [\[Transport Victoria\]](#)

Following delivery of the regional drainage infrastructure and associated road upgrades, regional catchment runoff will be fully contained within formal conveyance systems and prevented from entering the Site.

Under these ultimate conditions, runoff within the Site will be limited to direct rainfall on the parcel. Surface grading and internal drainage will capture frequent events and direct them toward the legal point of discharge, preventing ponding and the formation of flood depths prior to drainage capture. Consequently, no external flooding or upstream overland flow paths will interact with the Site.

5.3 Peak Flows Through Site

5.3.1 Existing Conditions

The modelled peak flood flows passing through the site and within the Derrimut Road swale drain, generated by the upstream catchment, are shown in Table 5-1 for the base-line (2030) and medium-term (2070) SSP3-7.0 climate change scenarios for the 1% and 20% AEP's.

Table 5-1 Peak Flow within Site (m³/s)

Peak Flow	SSP3-7.0-2030		SSP3-7.0-2070	
	1%AEP	20%AEP	1%AEP	20%AEP
North-West Overland Flow	1.1 m ³ /s	0.5 m ³ /s	1.4 m ³ /s	0.6 m ³ /s
Derrimut Road Swale	1.0 m ³ /s	0.4 m ³ /s	1.3 m ³ /s	0.5 m ³ /s

5.3.2 Developed Conditions

The revised Melbourne Water DSS removes regional runoff from the Site by intercepting upstream flows within the northern retarding basin (RB6) and conveying them through the 1200 mm trunk pipe. As a result, external overland flow paths no longer interact with the Site.

Under ultimate conditions the Site receives only direct rainfall runoff. Flood behaviour therefore becomes entirely localised and controlled by internal grading and drainage design. This fundamentally changes the risk profile from flood conveyance to stormwater management.

Under the ultimate developed conditions stormwater runoff generated within the site will be captured and conveyed within the site drainage system. The site drainage will consist of an underground pipe network to capture runoff generated from events up to and including the 10% AEP which will be connected to the drainage network within the greater Tarneit Logistics Hub, discharging ultimately to BA5/WL15.

The gap flows up to and including the 1% AEP event for the future medium-term climate change horizon 2070, will discharge to an open drain located within the existing Melbourne Water and Ausnet easement along the south-east boundary. The swale drain will direct surface flows along the easement to the downstream DSS asset BA5/WL15.

5.4 Flood Hazard

Flood hazard across the Site, under existing conditions, has a H1 category classification, indicating conditions are unrestricted (safe) for all movement.

Development of the site is expected to coincide with delivery of the DSS assets TA6 > TA7 > TA8 – the 1% AEP (Q100) pipe conveying stormwater runoff from the DSS basin RB6, through the TLH to the downstream basin Ba5.

The provision of the DSS drainage assets, construction of the greater Tarneit Logistics Hub development and the regrading work along Boundary Road and Derrimut Road; stormwater runoff from the northern catchment area will be captured and conveyed through the DSS infrastructure providing flood immunity to the site.

Under the post developed scenario, the site will no longer interact with regional flooding and and/or be at risk of flood hazards.

5.5 Bench Level Assessment

The removal of external flood impacts and flood flows approaching the site, means the Site can be developed without the need for regional flood mitigation measures. Finished surface levels will be designed to ensure positive drainage and compliance with design standards (AS5200).

5.6 Site Access and Flood Safety

Terminal Station access will be via a new road (Tiestone Court) from within the Tarneit logistics hub (refer Appendix C) Existing flooding across the site and future entrance location is shown to not be hazardous. The proposed development and construction of the DSS assets will facilitate the removal of flood depths from the site and entrance location. New roads will be designed to safely convey overland flows within safety thresholds. As such, site access will not be impeded during flood events up to and including the future 1% AEP medium-term (2070) horizon.

6 Conclusions

The revised Melbourne Water Drainage Scheme removes external catchment runoff from the Site. Stormwater Runoff affecting the development is therefore limited to rainfall falling directly on the parcel.

Provided finished levels are appropriately graded and internal drainage connects to the legal point of discharge, the development will:

- Not be subject to flooding
- Not cause adverse flood impacts
- Comply with Melbourne Water flood management intent
- Be suitable for planning approval subject to detailed design

Accordingly, the proposed development is considered acceptable from a flooding and stormwater management perspective under ultimate drainage scheme conditions.

7 Limitations

This Report is provided by WSP Australia Pty Limited (WSP) for Powercor Australia (Client) in response to specific instructions from the Client and in accordance with WSP's proposal dated December 10 2025 and agreement with the Client dated December 11 2025 (Agreement).

PERMITTED PURPOSE

This Report is provided by WSP for the purpose described in the Agreement and no responsibility is accepted by WSP for the use of the Report in whole or in part, for any other purpose (Permitted Purpose).

QUALIFICATIONS AND ASSUMPTIONS

The services undertaken by WSP in preparing this Report were limited to those specifically detailed in the Report and are subject to the scope, qualifications, assumptions and limitations set out in the Report or otherwise communicated to the Client.

Except as otherwise stated in the Report and to the extent that statements, opinions, facts, conclusion and / or recommendations in the Report (Conclusions) are based in whole or in part on information provided by the Client and other parties identified in the report (Information), those Conclusions are based on assumptions by WSP of the reliability, adequacy, accuracy and completeness of the Information and have not been verified. WSP accepts no responsibility for the Information.

WSP has prepared the Report without regard to any special interest of any person other than the Client when undertaking the services described in the Agreement or in preparing the Report.

USE AND RELIANCE

This Report should be read in its entirety and must not be copied, distributed or referred to in part only. The Report must not be reproduced without the written approval of WSP. WSP will not be responsible for interpretations or conclusions drawn by the reader. This Report (or sections of the Report) should not be used as part of a specification for a project or for incorporation into any other document without the prior agreement of WSP.

WSP is not (and will not be) obliged to provide an update of this Report to include any event, circumstance, revised Information or any matter coming to WSP's attention after the date of this Report. Data reported and Conclusions drawn are based solely on information made available to WSP at the time of preparing the Report. The passage of time; unexpected variations in ground conditions; manifestations of latent conditions; or the impact of future events (including (without limitation) changes in policy, legislation, guidelines, scientific knowledge; and changes in interpretation of policy by statutory authorities); may require further investigation or subsequent re-evaluation of the Conclusions.

This Report can only be relied upon for the Permitted Purpose and may not be relied upon for any other purpose. The Report does not purport to recommend or induce a decision to make (or not make) any purchase, disposal, investment, divestment, financial commitment or otherwise. It is the responsibility of the Client to accept (if the Client so chooses) any Conclusions contained within the Report and implement them in an appropriate, suitable and timely manner.



In the absence of express written consent of WSP, no responsibility is accepted by WSP for the use of the Report in whole or in part by any party other than the Client for any purpose whatsoever. Without the express written consent of WSP, any use which a third party makes of this Report or any reliance on (or decisions to be made) based on this Report is at the sole risk of those third parties without recourse to WSP. Third parties should make their own enquiries and obtain independent advice in relation to any matter dealt with or Conclusions expressed in the Report.

DISCLAIMER

No warranty, undertaking or guarantee whether expressed or implied, is made with respect to the data reported or the Conclusions drawn. To the fullest extent permitted at law, WSP, its related bodies corporate and its officers, employees and agents assumes no responsibility and will not be liable to any third party for, or in relation to any losses, damages or expenses (including any indirect, consequential or punitive losses or damages or any amounts for loss of profit, loss of revenue, loss of opportunity to earn profit, loss of production, loss of contract, increased operational costs, loss of business opportunity, site deprecation costs, business interruption or economic loss) of any kind whatsoever, suffered on incurred by a third party

ARR Data Hub
Appendix A



Results - ARR Data Hub
[STARTTXT]

Input Data Information
[INPUTDATA]
Latitude,-37.773000
Longitude,144.660000
[END_INPUTDATA]

River Region
[RIVREG]
Division,South East Coast (Victoria)
River Number,7
River Name,Werribee River
[RIVREG_META]
Time Accessed,18 December 2025 10:14AM
Version,2016_v1
[END_RIVREG]

ARF Parameters
[LONGARF]
Zone,Southern Temperate
a,0.158
b,0.276
c,0.372
d,0.315
e,0.000141
f,0.41
g,0.15
h,0.01
i,-0.0027
[LONGARF_META]
Time Accessed,18 December 2025 10:14AM
Version,2016_v1
[END_LONGARF]

Storm Losses
[LOSSES]
ID,3553.0
Storm Initial Losses (mm),11.0
Storm Continuing Losses (mm/h),0.3
[LOSSES_META]
Time Accessed,18 December 2025 10:14AM
Version,2016_v1
[END_LOSSES]

Temporal Patterns
[TP]
code,SSmainland
Label,Southern Slopes (Vic/NSW)
[TP_META]
Time Accessed,18 December 2025 10:14AM
Version,2016_v2
[END_TP]

Areal Temporal Patterns
[ATP]
code,SSmainland
arealabel,Southern Slopes (Vic/NSW)
[ATP_META]

Time Accessed,18 December 2025 10:14AM
Version,2016_v2
[END_ATP]

Median Preburst Depths and Ratios

[PREBURST]

min (h)\AEP(%) ,50,20,10,5,2,1

60 (1.0),2.2 (0.151),1.8 (0.083),1.4 (0.056),1.1 (0.037),1.2 (0.031),1.2 (0.028)
90 (1.5),2.4 (0.140),2.0 (0.084),1.8 (0.061),1.6 (0.045),1.7 (0.040),1.8 (0.037)
120 (2.0),1.1 (0.057),1.3 (0.049),1.4 (0.045),1.6 (0.042),1.5 (0.033),1.5 (0.028)
180 (3.0),1.5 (0.069),1.1 (0.036),0.8 (0.023),0.6 (0.013),2.0 (0.037),3.0 (0.049)
360 (6.0),0.4 (0.015),1.2 (0.031),1.7 (0.037),2.2 (0.040),3.5 (0.051),4.5 (0.057)
720 (12.0),0.0 (0.000),1.1 (0.022),1.8 (0.030),2.5 (0.035),4.3 (0.048),5.6 (0.054)
1080 (18.0),0.0 (0.000),0.5 (0.008),0.8 (0.011),1.1 (0.013),2.3 (0.022),3.2 (0.027)
1440 (24.0),0.0 (0.000),0.0 (0.000),0.0 (0.000),0.0 (0.000),0.3 (0.003),0.6 (0.004)
2160 (36.0),0.0 (0.000),0.0 (0.000),0.0 (0.000),0.0 (0.000),0.0 (0.000),0.0 (0.000)
2880 (48.0),0.0 (0.000),0.0 (0.000),0.0 (0.000),0.0 (0.000),0.0 (0.000),0.0 (0.000)
4320 (72.0),0.0 (0.000),0.0 (0.000),0.0 (0.000),0.0 (0.000),0.0 (0.000),0.0 (0.000)

[PREBURST_META]

Time Accessed,18 December 2025 10:14AM

Version,2018_v1

Note,Preburst interpolation methods for catchment wide preburst has been slightly altered. Point values remain unchanged.

[END_PREBURST]From preburst class

10% Preburst Depths

[PREBURST10]

min (h)\AEP(%) ,50,20,10,5,2,1

60 (1.0),0.0 (0.000),0.0 (0.000),0.0 (0.000),0.0 (0.000),0.0 (0.000),0.0 (0.000)
90 (1.5),0.0 (0.000),0.0 (0.000),0.0 (0.000),0.0 (0.000),0.0 (0.000),0.0 (0.000)
120 (2.0),0.0 (0.000),0.0 (0.000),0.0 (0.000),0.0 (0.000),0.0 (0.000),0.0 (0.000)
180 (3.0),0.0 (0.000),0.0 (0.000),0.0 (0.000),0.0 (0.000),0.0 (0.000),0.0 (0.000)
360 (6.0),0.0 (0.000),0.0 (0.000),0.0 (0.000),0.0 (0.000),0.0 (0.000),0.0 (0.000)
720 (12.0),0.0 (0.000),0.0 (0.000),0.0 (0.000),0.0 (0.000),0.0 (0.000),0.0 (0.000)
1080 (18.0),0.0 (0.000),0.0 (0.000),0.0 (0.000),0.0 (0.000),0.0 (0.000),0.0 (0.000)
1440 (24.0),0.0 (0.000),0.0 (0.000),0.0 (0.000),0.0 (0.000),0.0 (0.000),0.0 (0.000)
2160 (36.0),0.0 (0.000),0.0 (0.000),0.0 (0.000),0.0 (0.000),0.0 (0.000),0.0 (0.000)
2880 (48.0),0.0 (0.000),0.0 (0.000),0.0 (0.000),0.0 (0.000),0.0 (0.000),0.0 (0.000)
4320 (72.0),0.0 (0.000),0.0 (0.000),0.0 (0.000),0.0 (0.000),0.0 (0.000),0.0 (0.000)

[PREBURST10_META]

Time Accessed,18 December 2025 10:14AM

Version,2018_v1

Note,Preburst interpolation methods for catchment wide preburst has been slightly altered. Point values remain unchanged.

[END_PREBURST10]From preburst class

25% Preburst Depths

[PREBURST25]

min (h)\AEP(%) ,50,20,10,5,2,1

60 (1.0),0.1 (0.008),0.1 (0.003),0.0 (0.001),0.0 (0.000),0.0 (0.000),0.0 (0.000)
90 (1.5),0.1 (0.007),0.1 (0.003),0.0 (0.001),0.0 (0.000),0.0 (0.000),0.0 (0.000)
120 (2.0),0.0 (0.000),0.0 (0.000),0.0 (0.000),0.0 (0.000),0.0 (0.000),0.0 (0.000)
180 (3.0),0.0 (0.000),0.0 (0.000),0.0 (0.000),0.0 (0.000),0.0 (0.000),0.0 (0.000)
360 (6.0),0.0 (0.000),0.0 (0.000),0.0 (0.000),0.0 (0.000),0.1 (0.001),0.1 (0.002)
720 (12.0),0.0 (0.000),0.0 (0.000),0.0 (0.000),0.0 (0.000),0.0 (0.000),0.0 (0.000)
1080 (18.0),0.0 (0.000),0.0 (0.000),0.0 (0.000),0.0 (0.000),0.0 (0.000),0.0 (0.000)
1440 (24.0),0.0 (0.000),0.0 (0.000),0.0 (0.000),0.0 (0.000),0.0 (0.000),0.0 (0.000)
2160 (36.0),0.0 (0.000),0.0 (0.000),0.0 (0.000),0.0 (0.000),0.0 (0.000),0.0 (0.000)
2880 (48.0),0.0 (0.000),0.0 (0.000),0.0 (0.000),0.0 (0.000),0.0 (0.000),0.0 (0.000)
4320 (72.0),0.0 (0.000),0.0 (0.000),0.0 (0.000),0.0 (0.000),0.0 (0.000),0.0 (0.000)

[PREBURST25_META]

Time Accessed,18 December 2025 10:14AM

Version,2018_v1

Note,Preburst interpolation methods for catchment wide preburst has been slightly altered. Point values remain unchanged.

[END_PREBURST25]From preburst class

75% Preburst Depths

[PREBURST75]

min (h)\AEP(%),50,20,10,5,2,1

60 (1.0),11.0 (0.746),10.1 (0.479),9.5 (0.368),8.9 (0.289),11.6 (0.306),13.6 (0.311)
90 (1.5),10.4 (0.610),10.6 (0.440),10.7 (0.366),10.8 (0.311),11.6 (0.271),12.2 (0.246)
120 (2.0),5.4 (0.286),8.2 (0.310),10.0 (0.312),11.8 (0.309),13.5 (0.288),14.8 (0.272)
180 (3.0),9.8 (0.450),10.7 (0.356),11.4 (0.311),12.0 (0.276),15.0 (0.280),17.2 (0.277)
360 (6.0),3.8 (0.137),8.4 (0.218),11.5 (0.245),14.4 (0.259),16.2 (0.237),17.6 (0.222)
720 (12.0),1.2 (0.033),7.3 (0.145),11.4 (0.186),15.3 (0.210),19.4 (0.217),22.5 (0.218)
1080 (18.0),1.7 (0.041),5.7 (0.096),8.3 (0.115),10.8 (0.126),14.6 (0.140),17.5 (0.146)
1440 (24.0),2.3 (0.049),4.1 (0.063),5.3 (0.066),6.5 (0.068),9.6 (0.083),11.9 (0.090)
2160 (36.0),0.0 (0.000),0.8 (0.011),1.3 (0.015),1.9 (0.017),4.5 (0.034),6.5 (0.044)
2880 (48.0),0.0 (0.000),0.3 (0.003),0.4 (0.004),0.6 (0.005),2.1 (0.015),3.3 (0.020)
4320 (72.0),0.0 (0.000),0.0 (0.000),0.0 (0.000),0.0 (0.000),0.0 (0.000),0.0 (0.000)

[PREBURST75_META]

Time Accessed,18 December 2025 10:14AM

Version,2018_v1

Note,Preburst interpolation methods for catchment wide preburst has been slightly altered. Point values remain unchanged.

[END_PREBURST75]From preburst class

90% Preburst Depths

[PREBURST90]

min (h)\AEP(%),50,20,10,5,2,1

60 (1.0),31.4 (2.122),27.3 (1.295),24.6 (0.955),22.0 (0.717),24.8 (0.657),26.9 (0.617)
90 (1.5),21.2 (1.249),21.1 (0.880),21.0 (0.720),21.0 (0.603),24.6 (0.575),27.3 (0.552)
120 (2.0),16.8 (0.898),19.3 (0.733),20.9 (0.653),22.5 (0.591),33.0 (0.704),40.9 (0.754)
180 (3.0),18.8 (0.869),21.0 (0.696),22.4 (0.613),23.8 (0.548),30.0 (0.560),34.6 (0.558)
360 (6.0),13.2 (0.470),20.3 (0.523),25.0 (0.532),29.5 (0.530),31.6 (0.461),33.2 (0.418)
720 (12.0),16.2 (0.443),21.6 (0.427),25.2 (0.410),28.7 (0.393),37.7 (0.421),44.5 (0.430)
1080 (18.0),14.1 (0.334),16.9 (0.286),18.8 (0.261),20.6 (0.241),27.2 (0.260),32.1 (0.268)
1440 (24.0),10.3 (0.221),17.0 (0.259),21.5 (0.269),25.8 (0.271),28.1 (0.243),29.8 (0.225)
2160 (36.0),15.8 (0.302),15.0 (0.201),14.5 (0.159),14.1 (0.129),24.1 (0.183),31.6 (0.212)
2880 (48.0),0.5 (0.009),1.9 (0.024),2.9 (0.029),3.8 (0.032),12.4 (0.087),18.8 (0.117)
4320 (72.0),2.1 (0.035),3.7 (0.042),4.8 (0.044),5.8 (0.044),6.9 (0.045),7.8 (0.045)

[PREBURST90_META]

Time Accessed,18 December 2025 10:14AM

Version,2018_v1

Note,Preburst interpolation methods for catchment wide preburst has been slightly altered. Point values remain unchanged.

[END_PREBURST90]From preburst class

Climate Change Factors

[CCF]

[SSP1-2.6]

<1 hour,1.5 Hours,2 Hours,3 Hours,4.5 Hours,6 Hours,9 Hours,12 Hours,18 Hours,>24 Hours

2030,1.18,1.17,1.16,1.14,1.13,1.12,1.12,1.11,1.1,1.1
2040,1.21,1.19,1.17,1.16,1.15,1.14,1.13,1.12,1.11,1.11
2050,1.22,1.2,1.18,1.17,1.15,1.15,1.14,1.13,1.12,1.11
2060,1.23,1.21,1.2,1.18,1.17,1.16,1.15,1.14,1.13,1.12
2070,1.24,1.22,1.2,1.18,1.17,1.16,1.15,1.14,1.13,1.12
2080,1.23,1.21,1.2,1.18,1.17,1.16,1.15,1.14,1.13,1.12
2090,1.23,1.21,1.2,1.18,1.17,1.16,1.15,1.14,1.13,1.12

2100,1.22,1.2,1.19,1.17,1.16,1.15,1.14,1.13,1.12,1.12
 [END_SSP1-2.6]
 [SSP2-4.5]
 ,<1 hour,1.5 Hours,2 Hours,3 Hours,4.5 Hours,6 Hours,9 Hours,12 Hours,18 Hours,>24 Hours
 2030,1.18,1.17,1.16,1.14,1.13,1.12,1.12,1.11,1.1,1.1
 2040,1.22,1.2,1.19,1.17,1.16,1.15,1.14,1.13,1.12,1.12
 2050,1.27,1.24,1.23,1.21,1.19,1.18,1.17,1.16,1.15,1.14
 2060,1.3,1.27,1.25,1.23,1.21,1.2,1.19,1.18,1.16,1.16
 2070,1.33,1.3,1.28,1.26,1.24,1.22,1.21,1.19,1.18,1.17
 2080,1.37,1.33,1.31,1.28,1.26,1.24,1.22,1.21,1.2,1.19
 2090,1.4,1.36,1.34,1.31,1.28,1.26,1.24,1.23,1.21,1.2
 2100,1.41,1.37,1.35,1.32,1.29,1.27,1.25,1.24,1.22,1.21
 [END_SSP2-4.5]
 [SSP3-7.0]
 ,<1 hour,1.5 Hours,2 Hours,3 Hours,4.5 Hours,6 Hours,9 Hours,12 Hours,18 Hours,>24 Hours
 2030,1.18,1.17,1.16,1.14,1.13,1.12,1.12,1.11,1.1,1.1
 2040,1.23,1.21,1.2,1.18,1.17,1.16,1.15,1.14,1.13,1.12
 2050,1.29,1.26,1.24,1.22,1.2,1.19,1.18,1.17,1.16,1.15
 2060,1.35,1.32,1.3,1.27,1.25,1.23,1.22,1.2,1.19,1.18
 2070,1.42,1.38,1.35,1.32,1.29,1.28,1.26,1.24,1.22,1.21
 2080,1.5,1.45,1.42,1.38,1.35,1.33,1.3,1.28,1.26,1.25
 2090,1.59,1.53,1.49,1.44,1.4,1.38,1.35,1.33,1.3,1.29
 2100,1.66,1.59,1.55,1.5,1.45,1.42,1.39,1.37,1.34,1.32
 [END_SSP3-7.0]
 [SSP5-8.5]
 ,<1 hour,1.5 Hours,2 Hours,3 Hours,4.5 Hours,6 Hours,9 Hours,12 Hours,18 Hours,>24 Hours
 2030,1.2,1.18,1.17,1.16,1.14,1.13,1.13,1.12,1.11,1.11
 2040,1.26,1.24,1.22,1.2,1.18,1.17,1.16,1.15,1.14,1.14
 2050,1.34,1.31,1.29,1.26,1.24,1.23,1.21,1.2,1.18,1.18
 2060,1.42,1.38,1.35,1.32,1.29,1.28,1.26,1.24,1.22,1.21
 2070,1.52,1.47,1.43,1.4,1.36,1.34,1.31,1.29,1.27,1.26
 2080,1.63,1.57,1.52,1.48,1.43,1.4,1.37,1.35,1.33,1.31
 2090,1.77,1.69,1.64,1.58,1.52,1.49,1.45,1.42,1.39,1.37
 2100,1.86,1.77,1.71,1.64,1.58,1.54,1.5,1.47,1.43,1.41
 [END_SSP5-8.5]
 [Climate_Change_INITIAL_LOSS]
 ,Losses SSP1-2.6,Losses SSP2-4.5,Losses SSP3-7.0,Losses SSP5-8.5
 2030,1.05,1.05,1.05,1.05
 2040,1.05,1.06,1.06,1.07
 2050,1.06,1.07,1.07,1.08
 2060,1.06,1.07,1.09,1.1
 2070,1.06,1.08,1.1,1.12
 2080,1.06,1.09,1.12,1.14
 2090,1.06,1.09,1.13,1.17
 2100,1.06,1.1,1.15,1.19
 [END_Climate_Change_INITIAL_LOSS]
 [Climate_Change_CONTINUING_LOSS]
 ,Losses SSP1-2.6,Losses SSP2-4.5,Losses SSP3-7.0,Losses SSP5-8.5
 2030,1.1,1.1,1.1,1.11
 2040,1.12,1.12,1.13,1.14
 2050,1.12,1.15,1.16,1.18
 2060,1.13,1.17,1.19,1.23
 2070,1.13,1.18,1.23,1.28
 2080,1.13,1.2,1.27,1.33
 2090,1.13,1.21,1.31,1.39
 2100,1.12,1.22,1.34,1.44
 [END_Climate_Change_CONTINUING_LOSS]
 [TEMPERATURE_CHANGES]
 ,SSP1-2.6,SSP2-4.5,SSP3-7.0,SSP5-8.5
 2030,1.2,1.2,1.2,1.3

2040,1.3,1.4,1.5,1.6

2050,1.4,1.7,1.8,2.1

2060,1.5,1.9,2.2,2.5

2070,1.5,2.1,2.5,3.0

2080,1.5,2.2,2.9,3.5

2090,1.5,2.4,3.3,4.1

2100,1.4,2.5,3.6,4.5

[END_TEMPERATURE_CHANGES]

[CCF_META]

Time Accessed,18 December 2025 10:14AM

Version,2024_v1

Note,Updated climate change factors for IFD Initial loss and continuing loss based on IPCC AR6 temperature increases from the updated Climate Change Considerations (Book 1: Chapter 6) in ARR (Version 4.2). ARR recommends the use of Current and near-term (2030 midpoint). Medium-term (2050 midpoint) and Long-term (2090 midpoint)

[END_CCF]

[ENDTXT]

Flood Maps
Appendix B





Tarneit Hydrology Study
 SSP3-2030 20%AEP_CC
 Flood Depth

Legend

- Project Site
- Easement

SSP3-2030 20%AEP_CC Depth (m)

0.05 - 0.06
0.06 - 0.07
0.07 - 0.08
0.08 - 0.09
0.09 - 0.10
0.10 - 0.15
0.15 - 0.50
0.50 - 1.50
1.50 - 2.00

 Coordinate System: GDA2020 MGA Zone 55
 1:6,700 Date: 18/02/2026
 Data sources: WSP, Google Earth (2016)

0 250 500 m



©WSP Australia Pty Ltd ("WSP") Copyright in the drawings, information and data recorded ("the information") is the property of WSP. This document and the information are solely for the use of the authorised recipient and this document may not be used, copied or reproduced in whole or part for any purpose other than that which it was supplied by WSP. WSP makes no representation, undertakes no duty and accepts no responsibility to any third party who may use or rely upon this document or the information. NCSI Certified Quality System to ISO 9001. © APPROVED FOR AND ON BEHALF OF WSP Australia Pty Ltd.

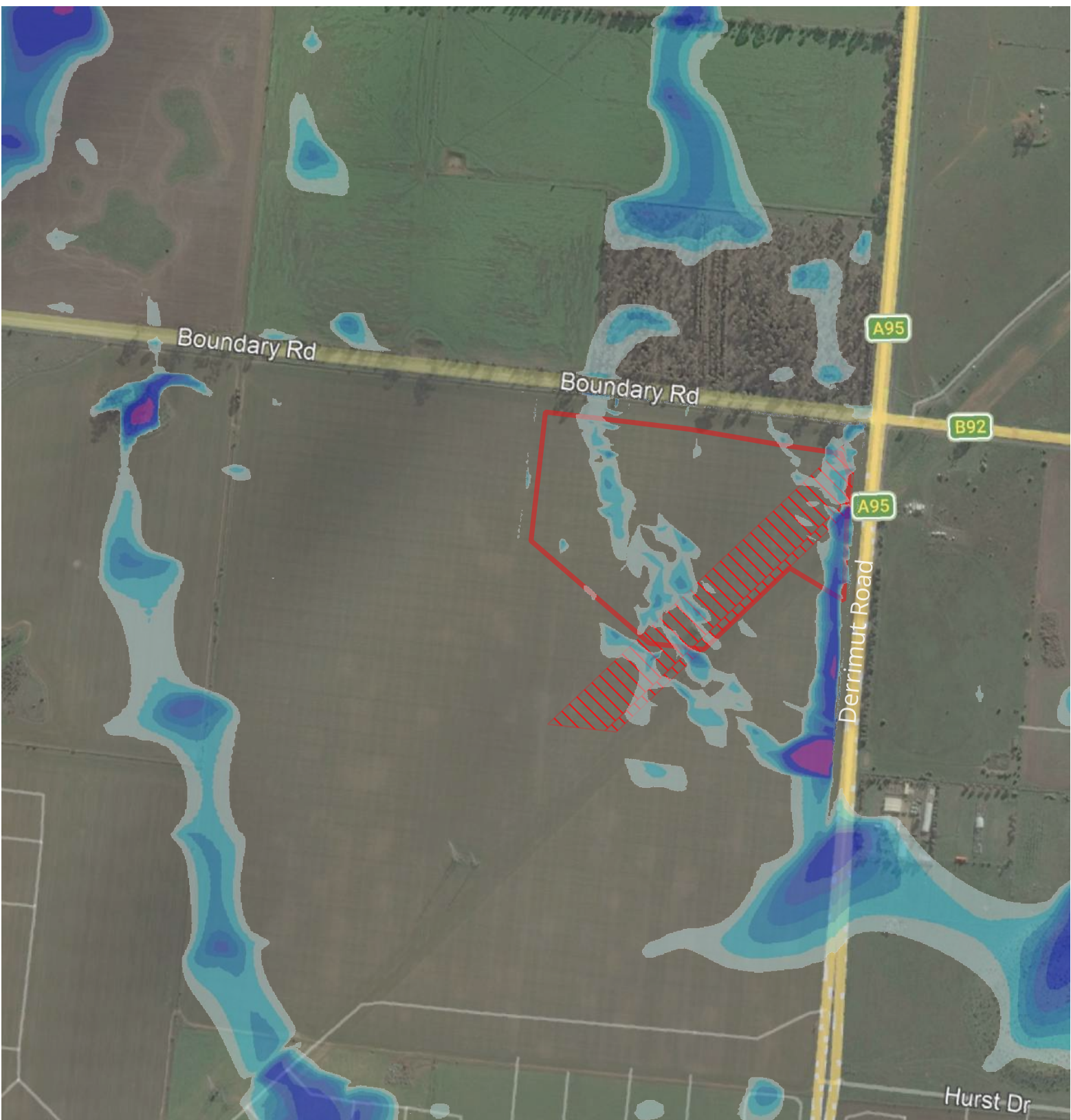

Tarneit Hydrology Study

SSP3-2030 1%AEP_CC

Flood Depth

Legend

- Project Site
- Easement

SSP3-2030 1%AEP_CC Depth (m)

	0.05 - 0.06
	0.06 - 0.07
	0.07 - 0.08
	0.08 - 0.09
	0.09 - 0.10
	0.10 - 0.15
	0.15 - 0.50
	0.50 - 1.50
	1.50 - 2.00

Coordinate System: GDA2020 MGA Zone 55
 1:6,700 Date: 18/02/2026
 Data sources: WSP, Google Earth (2016)

0 250 500 m



©WSP Australia Pty Ltd ("WSP") Copyright in the drawings, information and data recorded ("the information") is the property of WSP. This document and the information are solely for the use of the authorised recipient and this document may not be used, copied or reproduced in whole or part for any purpose other than that which it was supplied by WSP. WSP makes no representation, undertakes no duty and accepts no responsibility to any third party who may use or rely upon this document or the information. NCSI Certified Quality System to ISO 9001. © APPROVED FOR AND ON BEHALF OF WSP Australia Pty Ltd.



Tarneit Hydrology Study
 SSP3-2070 20%AEP_CC
 Flood Depth

Legend

- Project Site
- Easement

SSP3-2070 20AEP_CC Flood Depth (m)

0.05 - 0.06
0.06 - 0.07
0.07 - 0.08
0.08 - 0.09
0.09 - 0.10
0.10 - 0.15
0.15 - 0.50
0.50 - 1.50
1.50 - 2.00

 Coordinate System: GDA2020 MGA Zone 55
 1:6,700 Date: 18/02/2026
 Data sources: WSP, Google Earth (2016)

0 250 500 m



©WSP Australia Pty Ltd ("WSP") Copyright in the drawings, information and data recorded ("the information") is the property of WSP. This document and the information are solely for the use of the authorised recipient and this document may not be used, copied or reproduced in whole or part for any purpose other than that which it was supplied by WSP. WSP makes no representation, undertakes no duty and accepts no responsibility to any third party who may use or rely upon this document or the information. NCSI Certified Quality System to ISO 9001. © APPROVED FOR AND ON BEHALF OF WSP Australia Pty Ltd.



Tarneit Hydrology Study

SSP3-2070 1%AEP_CC

Flood Depth

Legend

- Project Site
- Easement

SSP3-2070 1%AEP_CC Flood Depth (m)

	0.05 - 0.06
	0.06 - 0.07
	0.07 - 0.08
	0.08 - 0.09
	0.09 - 0.10
	0.10 - 0.15
	0.15 - 0.50
	0.50 - 1.50
	1.50 - 2.00

Coordinate System: GDA2020 MGA Zone 55
 1:6,700 Date: 18/02/2026
 Data sources: WSP, Google Earth (2016)

0 250 500 m



©WSP Australia Pty Ltd ("WSP") Copyright in the drawings, information and data recorded ("the information") is the property of WSP. This document and the information are solely for the use of the authorised recipient and this document may not be used, copied or reproduced in whole or part for any purpose other than that which it was supplied by WSP. WSP makes no representation, undertakes no duty and accepts no responsibility to any third party who may use or rely upon this document or the information. NCSI Certified Quality System to ISO 9001. © APPROVED FOR AND ON BEHALF OF WSP Australia Pty Ltd.

Preliminary Development Plans
Appendix C



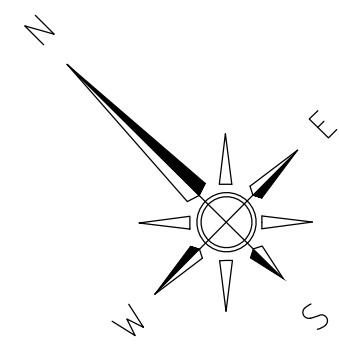

NOTES:

- ANY CHANGES MADE ON SITE SHALL BE CONFIRMED BY THE DESIGNER.
- REFER:
 - "SPIRE - 1005 BOUNDARY ROAD - TITLE RE-ESTABLISHMENT & LEVEL AND FEATURE SURVEY"
 - MCTS/TBC
 - MCTS/604/1
 - MCTS/TBC
- COORDINATES ARE GIVEN IN METRES TO MGA2020 ZONE 55.
- BASE LINES ARE INDICATED BY PERMANENT MARKERS WHICH SHALL CONSIST OF A STEEL MARKER LOCATED IN THE CENTRE OF A CONCRETE BLOCK.
- BASE LINE MARKS HAVE BEEN LOCATED OUT OF TRAFFICABLE AREAS.
- BASE LINES ARE ESTABLISHED TO ENSURE A CLEAR VIEW ALONG THEIR ALIGNMENTS.

SETOUT POINTS			
MARKER	Northing	Easting	COMMENT
BM1	581304.3 879	296934.625	DATUM MARKER
BM2	5813217.470	296769.526	DATUM MARKER
BM3	5813097.192	296990.681	DATUM INTERSECTION
BM4	581314.605	297040.532	DATUM MARKER
BM5	5813270.783	296825.582	DATUM INTERSECTION
BM6	5813290.684	296846.506	DATUM MARKER
SM1	5813025.802	296872.250	FENCE CORNER
SM2	5813017.929	29694.2429	FENCE CORNER
SM3	5813126.019	297056.073	FENCE CORNER
SM4	5813076.844	297120.385	FENCE CORNER
SM5	5813145.023	297119.888	FENCE CORNER
SM6	5813242.416	297129.828	FENCE CORNER
SM7	5813270.572	297119.396	FENCE CORNER
SM8	5813274.272	297086.248	FENCE CORNER
SM9	5813293.859	296969.395	FENCE CORNER
SM10	5813301.819	296924.528	FENCE CORNER
SM11	5813311.328	296855.209	FENCE CORNER
SM12	5813324.142	296738.025	FENCE CORNER
SM13	5813158.018	296719.380	FENCE CORNER
SM14	5813049.490	296844.908	FENCE CORNER
SM15	5813037.390	296858.903	FENCE CORNER
SM16	5813056.648	296851.097	FENCE CORNER
SM17	5813044.549	296865.092	FENCE CORNER

GATE SCHEDULE				
ITEM	TYPE	No.	CLEAR OPENING DIMENSIONS (mm)	DRAWING NUMBER
G1	DOUBLE (VEHICLE)	1	6000	MCTS/TBC
G2	DOUBLE (VEHICLE & PEDESTRIAN)	1	6000	MCTS/TBC
G3	PEDESTRIAN	1	900	MCTS/TBC

FENCE SCHEDULE			
ITEM	TYPE	LENGTH (m)	REFER DRAWING
F1	TBC	1259.1	MCTS/TBC
F2	TBC	37.5	MCTS/TBC

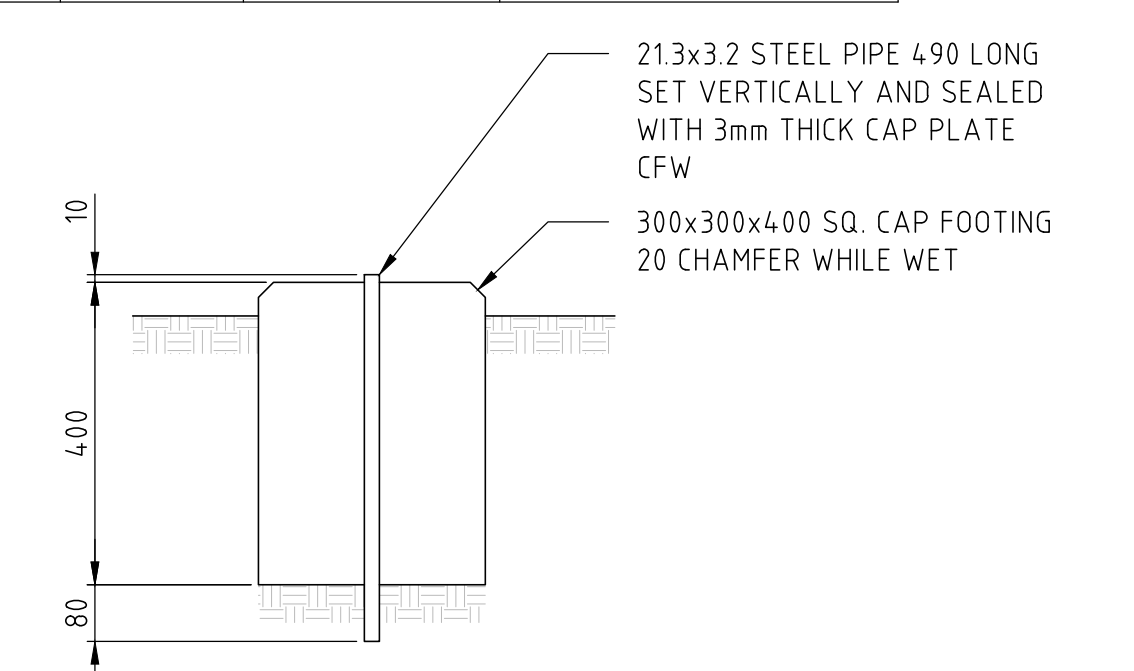

DATUM MARKER DETAILS
SCALE 1:10

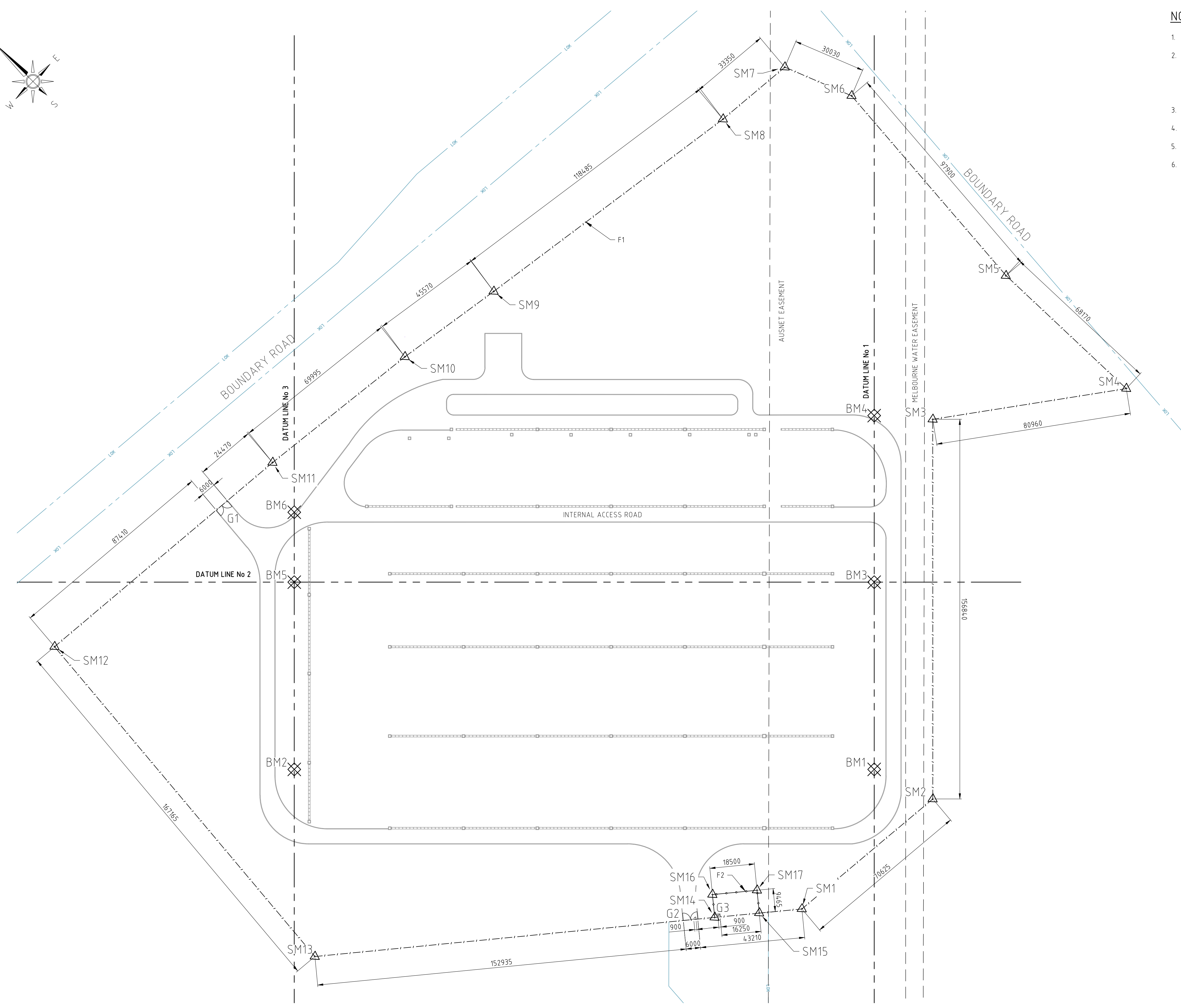

SITE PLAN
SCALE 1:750

- LEGEND**
- DATUM
 - ⊕ DATUM MARKER
 - △ FENCE MARKER
 - - - - SUBSTATION SECURITY FENCE (F1)
 - - - - COLORBOND SECURITY FENCE (F2)

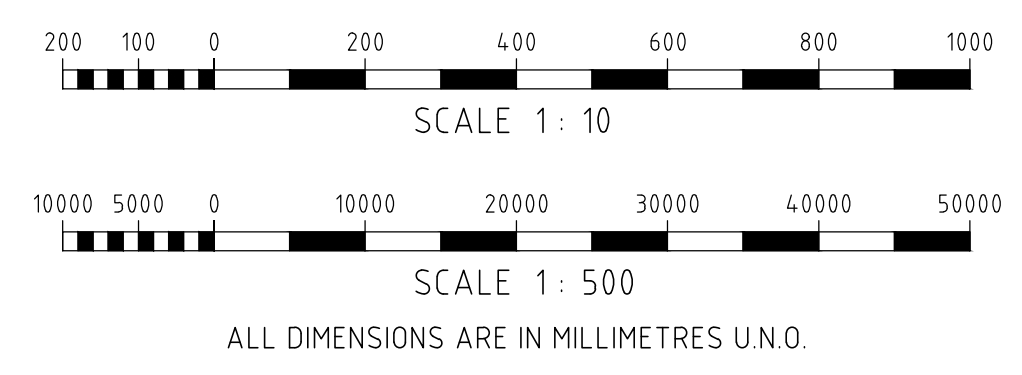

**FOR INFORMATION
NOT FOR CONSTRUCTION**

REFERENCE	
FENCE & GATE DETAILS	MCTS/TBC
SWITCHYARD BENCHING & EARTHWORKS PLAN & SECTIONS	MCTS/604/1
GENERAL ARRANGEMENT PLAN	MCTS/TBC

SCALE 1:750		REVISION 03/02/26	6057342 - ISSUED FOR INFORMATION		JB ABJ
DRAWING NUMBER	MCTS	603	-1	SHEET 1 OF 1	
Electricity Networks Locked Bag 14 090 Melbourne 8001 www.citipower.com.au www.powercor.com.au					
DRAWN J.Bessinger xx/xx/xx	DRAFTING CHECK xxx xx/xx/xx	DESIGNER J.Bessinger xx/xx/xx	DESIGN APPROVAL A.Britten-Jones xx/xx/xx	PROJECT MANAGER 6057342	
SUBSTATION MCTS - MOUNT COTTRELL SWITCHYARD FENCING & SITE SETOUT PLAN					

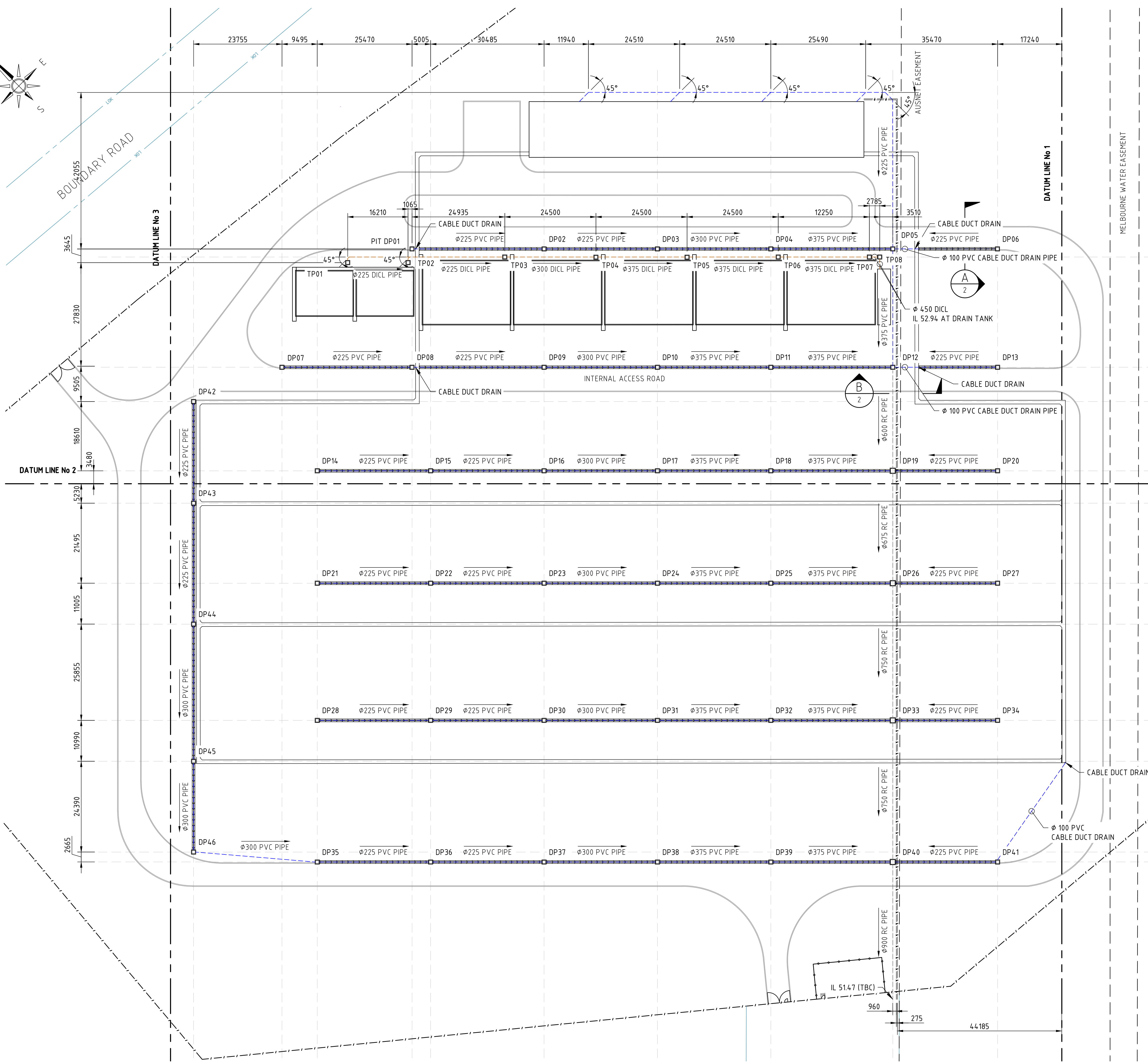
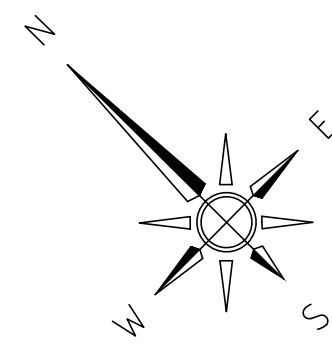

NOTES:

GENERAL:

1. REFER:

- MCTS/TBC FOR CIVIL & STRUCTURAL GENERAL NOTES
- MCTS/TBC FOR GENERAL ARRANGEMENT PLAN
- MCTS/TBC FOR FOUNDATION LAYOUT PLAN
- MCTS/605/2 FOR SWITCHYARD OIL CONTAINMENT & DRAINAGE DETAILS
- MCTS/604/1 FOR BENCHING & EARTHWORKS PLAN & DETAILS
- MCTS/TBC FOR WATER SUPPLY PLAN

DRAINAGE:

1. ALL STORMWATER DRAINAGE SHALL COMPLY WITH AS/NZS 3500.3
2. ALL REINFORCED CONCRETE (RC) PIPES SHALL BE OF MIN. CLASS 4 AS OER AS/NZS4058-2007 WITH FLUSH JOINTS AND EXTERNAL JOINT BANDS.
3. RC PIPE SUPPORT SHALL BE TYPE H2 AS PER AS/NZS3725-2007 WITH 3% CEMENT STABILISED BEDDING MATERIAL.
4. PVC PIPES SHALL BE CLASS SN4 AS PER AS/NZS1254-2010 WITH ALL JOINTS FULLY GLUED AND PIT ENTRIES GROUTED WITH 40 MPa NON-SHRINK GROUT.
5. PVC PIPE BACKFILL SHALL BE WASHED SAND COMPACTED TO 95% SMD. PVC PIPES SHALL BE BACKFILLED WITH MIN 100mm 5% CEMENT-SATBILISED SAND FOR ROAD CROSSING SECTIONS AS SHOWN.
6. ALL CABLE DUCTS SHALL BE DRAINED AT THE LOWEST POINT WITH Ø100 PVC DRAIN PIPE. DRAIN PIPES SHALL BE FITTED WITH ALLPROOF STORMWATER DRAIN.
7. A MINIMUM OF 450mm COVER SHALL BE MAINTAINED OVER ALL BUILDING PVC DOWN PIPES AND CABLE DUCT PVC DRAIN PIPES.
8. ALL DRAINAGE PIPEWORK SHALL BE FLUSHED CLEAN AND CAMERA-SURVEYED PROMPTLY AFTER FINAL BACKFILL & COMPACTION AT THE DISCRETION OF NS ENGINEER. FOOTAGE SHALL BE PROVIDED TO THE NS ENGINEER WITHIN 5 DAYS OF BACKFILLING.

SUBSTATION DRAINAGE PLAN
SCALE 1500

- LEGEND:**
- DATUM LINE
 - / - / SUBSTATION SECURITY FENCE
 - / - / COLORBOND SECURITY FENCE
 - w WATER PIPEWORK
 - s SEWER PIPEWORK
 - - - - PVC PIPE (DRAIN PIPEWORK)
 - - - - DICL PIPE (DRAIN PIPEWORK)
 - - - - RCP PIPE (DRAIN PIPEWORK)
 - ▨ DISHED INVERT

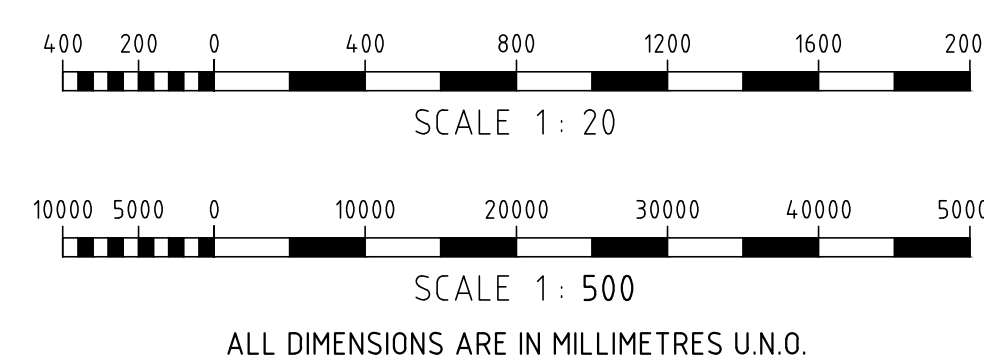

REFERENCE	CIVIL & STRUCTURAL GENERAL NOTES	MCTS/TBC
	SWITCHYARD WATER SUPPLY PLAN	MCTS/TBC
	SWITCHYARD BENCHING & EARTHWORKS PLAN & SECTIONS	MCTS/604/1
	SWITCHYARD OIL CONTAINMENT & DRAINAGE - DETAILS	MCTS/605/2
	SWITCHYARD FOUNDATION PLAN	MCTS/TBC
	GENERAL ARRANGEMENT PLAN	MCTS/TBC

**FOR INFORMATION
NOT FOR CONSTRUCTION**

SCALE 1:500		REVISION 03/02/26	6057342 - ISSUED FOR INFORMATION		JB ABJ
DRAWING NUMBER	MCTS	605	1	-1	SHEET 1 OF 2
Electricity Networks Locked Bag 14090 Melbourne 8001 www.citipower.com.au www.powercor.com.au					
DRAWN	DRAFTING CHECK	DESIGNER	DESIGN APPROVAL	PROJECT MANAGER	
J.Bessinger xx/xx/xx	xxx xx/xx/xx	J.Bessinger xx/xx/xx	A.Britten-Jones xx/xx/xx	XXX	

NOTE: EXISTING SERVICES
ALL EXISTING SERVICES UNDER NEW AND PROPOSED ROAD PAVEMENT, FOOTPATH AND DRIVEWAYS TO BE FCR BACKFILLED.

NOTE: EXISTING STRUCTURES
ALL EXISTING DRAINAGE PITS AND SEWER STRUCTURES WITHIN NEW WORKS ARE TO BE ADJUSTED TO MATCH NEW FINISHED SURFACE LEVELS.

TABLE OF SERVICE LOCATIONS

STREET NAME	SEW	GAS	DW	COMS	ELEC	POLES	BOK
TIESTONE COURT	1.00 N/S	*2.10 S	2.90 S	1.80 N	2.30 N	**0.80	4.75 N / 4.75 S

* ALLOWANCE ONLY ** FROM BACK OF KERB

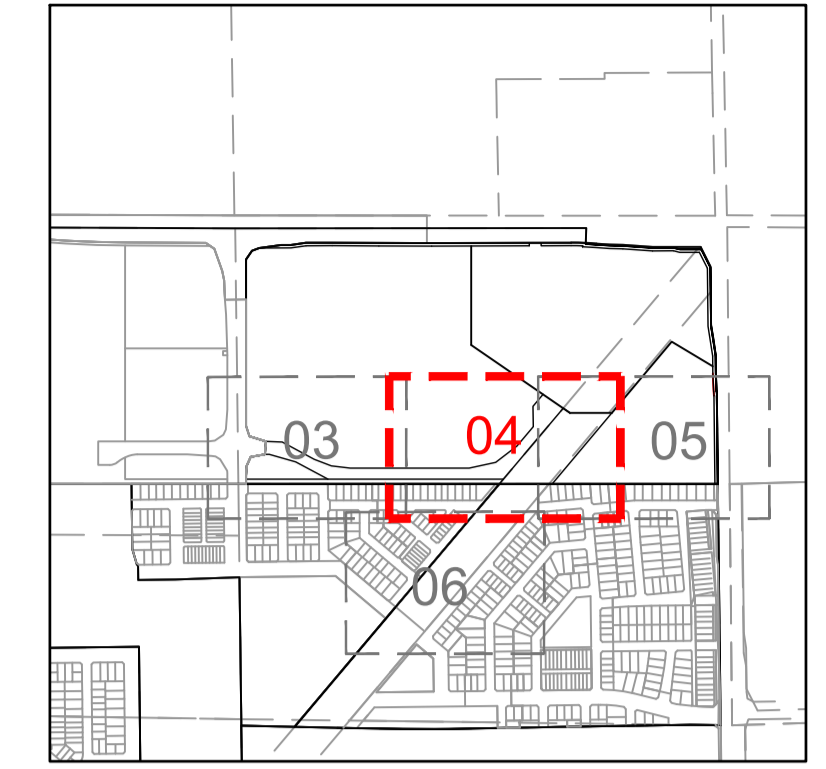

KEY PLAN
NOT TO SCALE

TBM SCHEDULE

I.D.	TYPE	EASTING	NORTHING	LEVEL
01	STAR PICKET	295564.58	5813486.50	55.91
02	SPIKE	295949.93	5813440.94	56.96
03	STAR PICKET	296340.46	5813393.93	56.22
04	STAR PICKET	296809.73	5813342.49	55.65
05	STAR PICKET	297141.37	5813304.90	54.36
06	STAR PICKET	295520.83	5813060.37	53.95
07	STAR PICKET	295921.00	5813007.09	53.93
08	STAR PICKET	296298.26	5812965.98	53.02
09	STAR PICKET	296853.06	5812925.03	52.94
10	STAR PICKET	297103.51	5812873.74	-
11	STAR PICKET	295564.15	5813274.08	54.73
12	STAR PICKET	295556.51	5813096.14	53.80
13	STAR PICKET	295537.81	5813039.03	53.64
14	STAR PICKET	295526.90	5812874.23	53.01
15	NAIL	295598.31	5812795.46	-
16	STAR PICKET	295688.45	5812701.14	-
17	STAR PICKET	296547.21	5812756.09	52.01
18	STAR PICKET	296692.80	5812534.00	51.06
19	STAR PICKET	296928.13	5812510.18	50.50

NOTE: TBM'S
TBM'S SHOWN IN THE TABLE ABOVE ARE OUTSIDE OF THE SCOPE OF THIS DRAWING. REFER TO SHEET 01/03 FOR LOCATION OF TBM'S IN RELATION TO BOUNDARY ROAD WORKS.

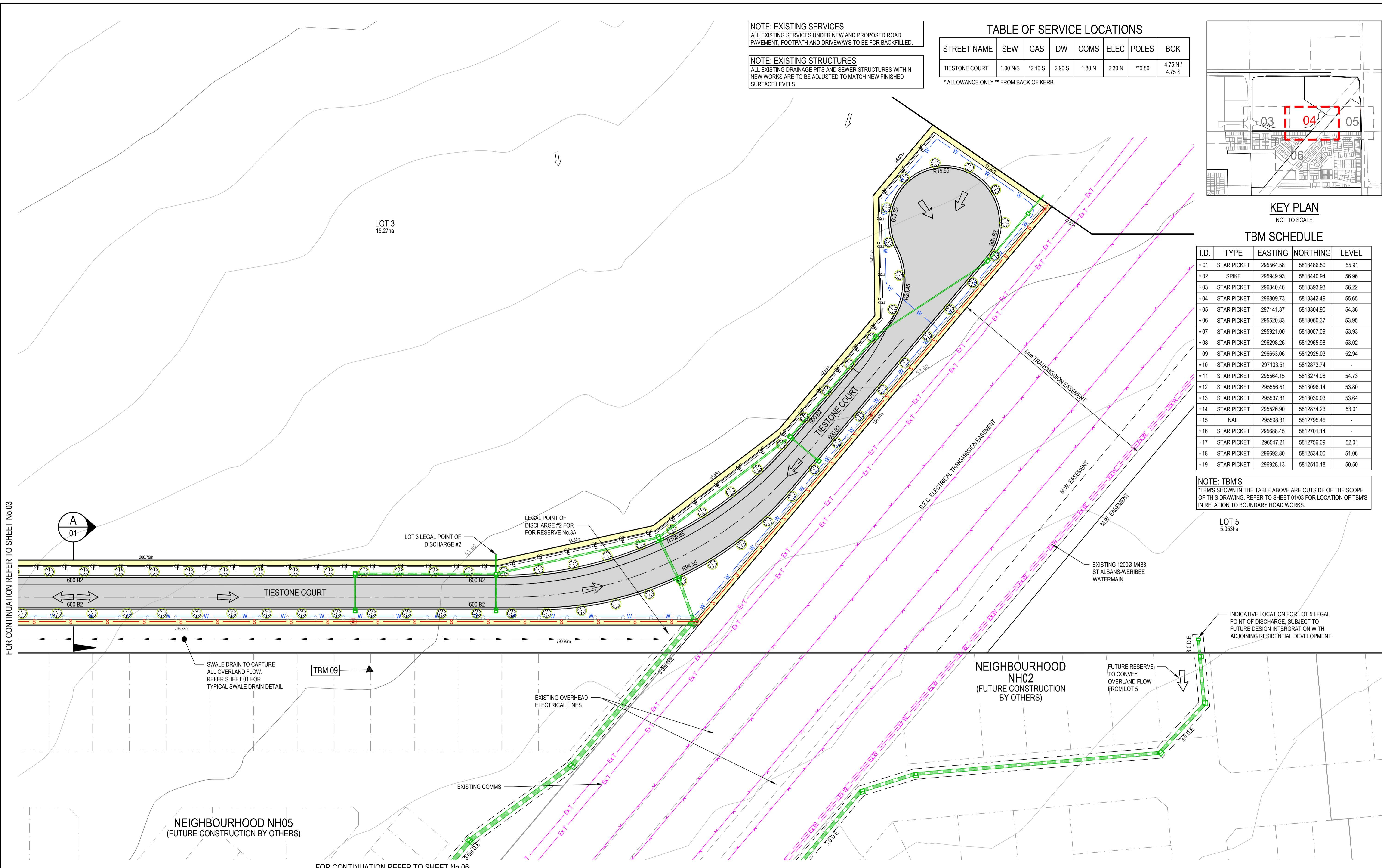

FOR CONTINUATION REFER TO SHEET No.03

FOR CONTINUATION REFER TO SHEET No.05

REV	DESCRIPTION	DATE	AMEND	APP'D
E	UPDATED TO P.O.S. VER. H			
D	COUNCIL ISSUE	29/11/24	GA/RNB	RMS
C	CLIENT ISSUE	03/09/24	GA/RY	RMS
B	INITIAL ISSUE	30/06/23	SR/FM	SR
A	INITIAL ISSUE	06/02/23	PN/FM	SR

Drawn: R. YOUNG
Date: 20/06/24
AN 1991340
Designed: G. ANTON
Date: 12/06/24
AN 3911053
Checked: R. SABER
Date: 29/11/24
AN 1481634
Reg. Eng. Date: 06/02/23
Date: PN/FM
Reg. No. SR
PLANS REQUIRE REG. ENG. APPROVAL

LEGEND

- SW DRAIN & PIT
- SEWER MAIN & MANHOLE
- ELECTRICITY
- GAS (ALLOWANCE ONLY)
- WATER
- OPTIC FIBRE
- SIGNAGE
- LIMIT OF WORKS
- EXISTING COMMS
- EXISTING WATER
- EX OVERHEAD ELECTRICAL
- PROPOSED STREET TREE WITH 8M TREE RING
- REGRADE LOT (MIN 1:150)
- OVERLAND FLOW ARROW
- EXISTING TREE TO BE REMOVED
- SW MD DRAIN & PIT (ADJ. WORKS)
- SEWER MAIN & MH (ADJ. WORKS)
- ELECTRICITY (ADJ. WORKS)
- OPTIC FIBRE (ADJ. WORKS)
- WATER (ADJ. WORKS)
- ASPHALT PAVEMENT
- CONCRETE PATH
- LANDSCAPING
- RELOCATED DSW (ADJACENT)
- SWALE
- PSM / TBM

Coordinates: MGA2020
Levels: AHD
Scale @ A1/A3: 0m 5m 10m 20m 30m
Scale: 1:500 / 1:1000

TARNEIT LOGISTICS HUB
STAGE 2
1005 BOUNDARY ROAD, TARNEIT
WYNDHAM CITY COUNCIL
DETAIL PLAN
SHEET 02 OF 04
Drawing No: 20264.2FDP02
Revision: D
Sheet No: 04 of 12

REVISION IN PROGRESS
DRAWING SUITABLE FOR INTERNAL DCE USE ONLY
FUNCTIONAL

Drawing File: C:\1\2d\Synergy\Verba\ENERGY-ME\20264-2\Tarnet_Logistics_Hub - Stage_2\2414\3 Design\1_ACAD\3_GENERAL\FUNCTIONAL_PLANS\20264.2FDP02.dwg - DWG
Date/Time: Fri Jun 21, 2024 - 2:45pm - chrisb

TLH DSS Asset Delivery
Appendix D



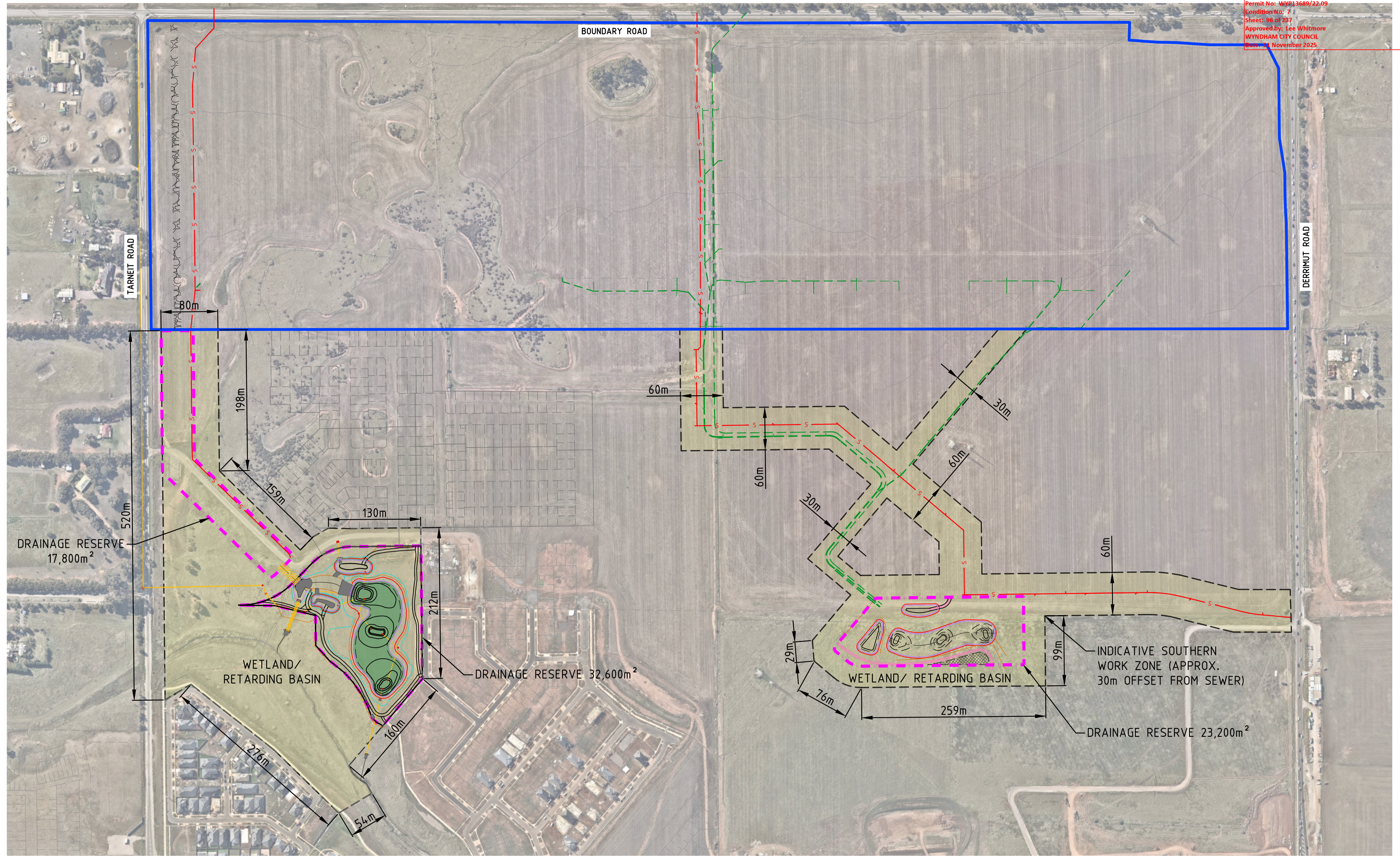

DRAINAGE RESERVE
 17,800m²

WETLAND/
 RETARDING BASIN

DRAINAGE RESERVE 32,600m²

WETLAND/
 RETARDING BASIN

INDICATIVE SOUTHERN
 WORK ZONE (APPROX.
 30m OFFSET FROM SEWER)

DRAINAGE RESERVE 23,200m²

BOUNDARY RD & DERRIMUT RD, TRUGANINA
 1110 DOHERTY ROAD, TARNEIT
 ACCESS PLAN FOR EXTERNAL
 SEWER AND DRAINAGE WORKS
 DCE REF 20264SK02
 DRAWN BY G.ANTON
 REVISION F
 REV DATE 15/08/2024

Charter Hall

Scale @ A1/A3 1:2500 / 1:5000

LEGEND

	SW DRAIN
	SEWER MAIN
	ACCESS AREA
	FLOODWAY
	DRAINAGE RESERVE BOUNDARY

NOTE
 AREAS AND DIMENSIONS SHOWN ON THIS PLAN
 ARE APPROXIMATE ONLY AND ARE SUBJECT TO
 DETAIL DESIGN AND AUTHORITY APPROVAL

BEFORE YOU DIG
 www.byda.com.au

DALTON CONSULTING ENGINEERS
 ABN 78 429 221 049
 VICTORIA
 T 61 3 9813 7400
 W dceng.com.au
 QUEENSLAND
 T 61 7 3374 9000
 E info@dceng.com.au

Drawing File: C:\Users\gndregm\Desktop\20264SK02.dwg - 20264SK02.dwg
 2026/08/15 10:23:30 AM - 2026/08/15 10:23:30 AM - Gndregm