



**APPENDIX 7 TRAFFIC IMPACT ASSESSMENT**

**AP07**

**ADVERTISED  
PLAN**

**This copied document to be made available  
for the sole purpose of enabling  
its consideration and review as  
part of a planning process under the  
Planning and Environment Act 1987.  
The document must not be used for any  
purpose which may breach any  
copyright**

# TRAFFIC IMPACT ASSESSMENT

## Project 4G – Integrated Egg Laying Operation



Traffic Engineering Report

**Client** McLean Farms Australia Pty Ltd

**Project Number** 25E-0010

## REPORT CONTROL SHEET

Report Details	
<b>Report Title:</b>	Traffic Impact Assessment – Project 4G – Integrated Egg Laying Operation
<b>Project No.:</b>	25E-0010
<b>Site:</b>	Torrumbarry, Victoria
<b>Authors:</b>	Christian Tedman Angel Baker Isobella Kerridge

Document Control					
Revision	Author	Reviewer	Approved for Issue		
			Name	Signature	Date
1	C Tedman A Baker I Kerridge	A Baker A Gwatking	Adam Gwatking	 CPEng, NER, RPEV: PE0017373 RPEQ: 15158	14 / 08 / 2025
2	A Baker	A Baker A Gwatking	Adam Gwatking	 CPEng, NER, RPEV: PE0017373 RPEQ: 15158	15 / 10 / 2025

*\*Revision 2 – updates have been completed to address comments / feedback received from the Department of Transport and Planning (DTP) and referral agencies as part of the draft planning permit application submission in September 2025.*

### Copyright © 2025 by RMA Engineers:

*All rights reserved. This report or any portion thereof may not be reproduced or used in any manner whatsoever without the express written permission of RMA Engineers Pty Ltd.*

### Disclaimer:

*RMA Engineers has undertaken this report based on accepted traffic engineering practices, standards, and information available at the time of writing. It is not intended as a quote, guarantee or warranty and does not cover any latent defects. RMA Engineers do not accept any responsibility for the authentication of accuracy of supplied information or validation of data that is outside the scope of works. RMA Engineers are not accountable for any changes to the standards, physical infrastructure conditions or planning impacts that occur after the completion date of the assessment.*

*The conclusions in this report should not be read in isolation. We recommend that its contents be reviewed in person with the author so that the assumptions and available information can be discussed in detail to enable the reader to make their own risk assessment in conjunction with information from other sources.*

*The document is produced by RMA Engineers for the sole benefit and use by the client in accordance with the contracted terms. RMA Engineers does not assume responsibility or liability to any third party arising from any use or reliance on the content of this document.*

# Contents

<b>REPORT CONTROL SHEET .....</b>	<b>1</b>
<b>1. Introduction .....</b>	<b>5</b>
1.1 Report objectives and scope .....	5
1.2 Reference material .....	6
<b>2. Proposed development.....</b>	<b>7</b>
2.1 Location and descriptions.....	7
2.1.1 Ultimate operation .....	7
2.1.2 Pollock’s Block Rearing Farm .....	7
2.1.3 Warwick’s Block Cage-Free Layer Farm.....	9
2.1.4 T-Block Free-Range Layer Farm and ‘Organic Nutrients’ Composting Facility .....	11
<b>3. Development details .....</b>	<b>14</b>
3.1 Pollock’s Block Rearing Farm .....	14
3.1.1 Operational and staging details.....	14
3.1.2 Expected traffic movements and design vehicles .....	14
3.2 Warwick’s Block Cage-Free Layer Farm.....	17
3.2.1 Operational and staging details.....	17
3.2.2 Expected traffic movements and design vehicles .....	17
3.3 T-Block Free Range Layer Farm.....	20
3.3.1 Operation and staging details .....	20
3.3.2 Expected traffic movements and design vehicles .....	20
3.4 Organic Nutrients Composting Facility.....	23
3.4.1 Operational details and staging.....	23
3.4.2 Expected traffic movements and design vehicles .....	23
3.5 Summary .....	25
3.5.1 Servicing and visitors .....	25
3.5.2 Waste and refuse collection .....	25
<b>4. Existing transport environment.....</b>	<b>27</b>
4.1 Surrounding road network .....	27
4.2 Key roads .....	28
4.2.1 Murray Valley Highway.....	28
4.2.2 Roslynmead Road.....	29
4.2.3 Heppell Road.....	30
4.2.4 Davis Road.....	31
4.2.5 Chrystal Road.....	32
4.2.6 Baillieu Road .....	33
4.3 Key intersections .....	34
4.3.1 Murray Valley Highway / Roslynmead Road / Bail Road .....	35
4.3.2 Murray Valley Highway / Heppell Road.....	36
4.3.3 Murray Valley Highway / Davis Road.....	37
4.3.4 Roslynmead Road / Chrystal Road .....	38

4.3.5	Baillieu Road / Chrystal Road .....	39
4.4	Crash data .....	39
4.4.1	Crash data for past 5 year period.....	39
4.4.2	Crash data for past 15-year period .....	41
4.5	Existing traffic volumes.....	43
4.5.1	Survey data .....	43
4.5.2	First principles assessment – Heppell Road and Chrystal Road traffic volumes.....	43
4.5.3	Historical growth rate.....	44
4.5.4	Heavy vehicle percentages .....	44
4.5.5	Assessment scenarios .....	45
<b>5.</b>	<b>Planning considerations.....</b>	<b>46</b>
<b>6.</b>	<b>Development traffic volumes .....</b>	<b>47</b>
<b>7.</b>	<b>Development traffic impact on external road network .....</b>	<b>48</b>
7.1	Intersection operational assessment.....	48
7.1.1	Assessment area.....	48
7.1.2	Assessment scenarios .....	49
7.1.3	Intersection modelling parameters .....	49
7.2	Intersection operational assessment results .....	49
7.3	Mid-block assessment (link level of service).....	51
<b>8.</b>	<b>Safety considerations .....</b>	<b>52</b>
8.1	Crash data .....	52
8.2	Turn warrant assessment.....	52
8.3	Safe intersection sight distance assessment .....	54
8.3.1	Safe intersection sight distance .....	54
8.4	Suitability of surrounding road network .....	55
8.4.1	Murray Valley Highway.....	56
8.4.2	Roslynmead Road.....	56
8.4.3	Heppell Road.....	56
8.4.4	Davis Road .....	57
8.4.5	Chrystal Road.....	57
8.4.6	Baillieu Road .....	58
8.5	Suitability of surrounding intersections (swept path assessment) .....	60
8.5.1	Murray Valley Highway / Davis Road .....	60
8.5.2	Murray Valley Highway / Heppell Road.....	63
8.5.3	Murray Valley Highway / Roslynmead Road / Bail Road .....	64
8.5.4	Roslynmead Road / Chrystal Road .....	66
8.5.5	Baillieu Road / Chrystal Road .....	68
8.6	Risk assessment .....	70
<b>9.</b>	<b>Site layout review .....</b>	<b>71</b>
9.1	Site access review.....	71
9.2	Car parking review .....	72
9.2.1	Car parking requirements.....	72
9.2.2	Car parking geometry.....	72

9.2.3	Provisions for persons with disabilities (PWD).....	72
9.2.4	Car parking summary .....	73
<b>10.</b>	<b>Implementation plan .....</b>	<b>74</b>
<b>11.</b>	<b>Summary and recommendations .....</b>	<b>80</b>
<b>Appendix A</b>	<b>Development layout.....</b>	<b>85</b>
<b>Appendix B</b>	<b>Proposed travel route maps .....</b>	<b>86</b>
<b>Appendix C</b>	<b>Traffic count data .....</b>	<b>87</b>
<b>Appendix D</b>	<b>Background traffic volumes .....</b>	<b>88</b>
<b>Appendix E</b>	<b>Development traffic volumes.....</b>	<b>89</b>
<b>Appendix F</b>	<b>SIDRA analysis results .....</b>	<b>90</b>
<b>Appendix G</b>	<b>Turn warrant assessment .....</b>	<b>91</b>
<b>Appendix H</b>	<b>Intersection concept sketches and swept path assessment .....</b>	<b>92</b>
<b>Appendix I</b>	<b>Crash data provided by Transport for Victoria .....</b>	<b>93</b>

# 1. Introduction

RMA Engineers has been engaged by McLean Farms Australia Pty Ltd (the Client) to undertake a Traffic Impact Assessment (TIA) in support of development applications for a proposed poultry Integrated Egg Laying operation located in Torrumbarry, Victoria.

The proposed development is located within the Campaspe Shire Council (CSC) and includes the following sites:

- Chick rearing farm, referred to as Pollock's Block Rearing Farm (720,000 birds)
- Cage-free laying farm, referred to as Warwick's Block Cage Free Layer Farm (1,280,000 birds)
- Free-range laying farm, referred to as T-Block Free Range Layer Farm (800,000 birds)
- Composting facility, referred to as 'Organic Nutrients' Composting Facility

The proposed infrastructure will include a total of 36 laying sheds, 16 cage-free and 20 free-range, and 18 rearing sheds with associated ancillary infrastructure.

This report has been prepared in support of the development applications for the proposed Integrated Egg Laying operation. Three separate development applications will be lodged concurrently for assessment by the Victorian Minister for Planning.

Given the level of integration of traffic movements associated between the different proposed sites, the traffic assessment has been considered for the entire Integrated Egg Laying operation (all sites). This report considers the traffic impacts of the ultimate development scenario.

This traffic impact assessment has been undertaken in general accordance with the road transport related requirements identified in Austroads Guide to Traffic Management – Part 12: *Integrated Transport Assessments for Developments (2020)*.

## 1.1 Report objectives and scope

The purpose of this traffic impact assessment (TIA) is to document an investigation of traffic and transport impacts of the proposed development on the surrounding road network.

The assessment considers the following:

- Estimation of traffic generation by the development and distribution on the surrounding road network.
- Review of potential operational impacts at the key intersections with the proposed development influence at the year of completion and ten year design horizon.
- Review of key intersection layouts and turn warrants.
- Safety considerations, review of historical crash data and commentary on required mitigation measures.
- Assessment of sight distance in accordance with Austroads requirements.
- High level review of the proposed development layout against relevant standards.

Where required, this report makes recommendations for the mitigation of development impacts.

## 1.2 Reference material

In preparing this report, reference has been made to the following:

- Austroads Guide to Traffic Management – Part 12: *Integrated Transport Assessments for Developments (2020)*.
- Australian Standard AS28901.1 *Off Street Car Parking (2004)*
- Austroads Guide to Road Design, Part 3: *Geometric Design (2023)*
- Austroads Guide to Road Design, Part 4A: *Unsignalised and Signalised Intersections (2023)*
- Institute of Public Works Engineering Australasia (IPWEAQ) *Lower Order Roads Design Guidelines (2016)*
- *CSC Planning Scheme* (last updated 4 July 2025)
- Other documents as referenced within this report, including information supplied by the client.

## 2. Proposed development

### 2.1 Location and descriptions

#### 2.1.1 Ultimate operation

The ultimate proposed development will comprise of a Rearing Farm, a Cage Free Layer Farm, a Free Range Layer Farm and an ancillary Composting Facility, to establish an Integrated Egg Laying operation.

Refer to **Figure 2-1** and **Appendix A** for the proposed concept plan of the overall operation.

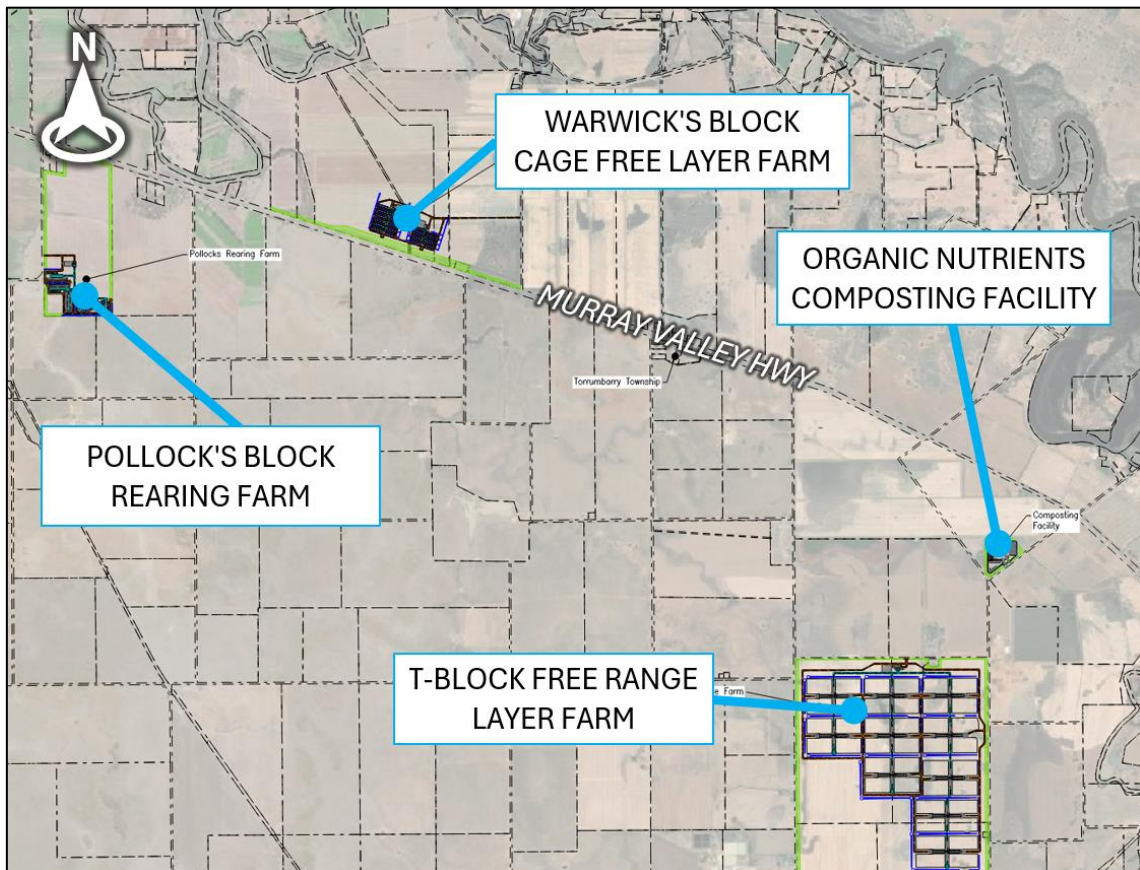

**Figure 2-1: Ultimate concept layout plan**

The following subsections outline the locations and descriptions of each site operation.

#### 2.1.2 Pollock's Block Rearing Farm

The proposed Pollock's Block Rearing Farm is located on the Murray Valley Highway on land described as Lot 4 on LP206281.

The site is approximately 124.16ha in area and is located within the Farming Zone under the CSC Planning Scheme. The site is current farmland (cropping/grazing) and has minimal tree coverage.

The property is bounded by the Murray Valley Highway along the northern boundary and Davis Road along the western boundary.

The Pollock's Block Rearing Farm site locality is shown in **Figure 2-2**.

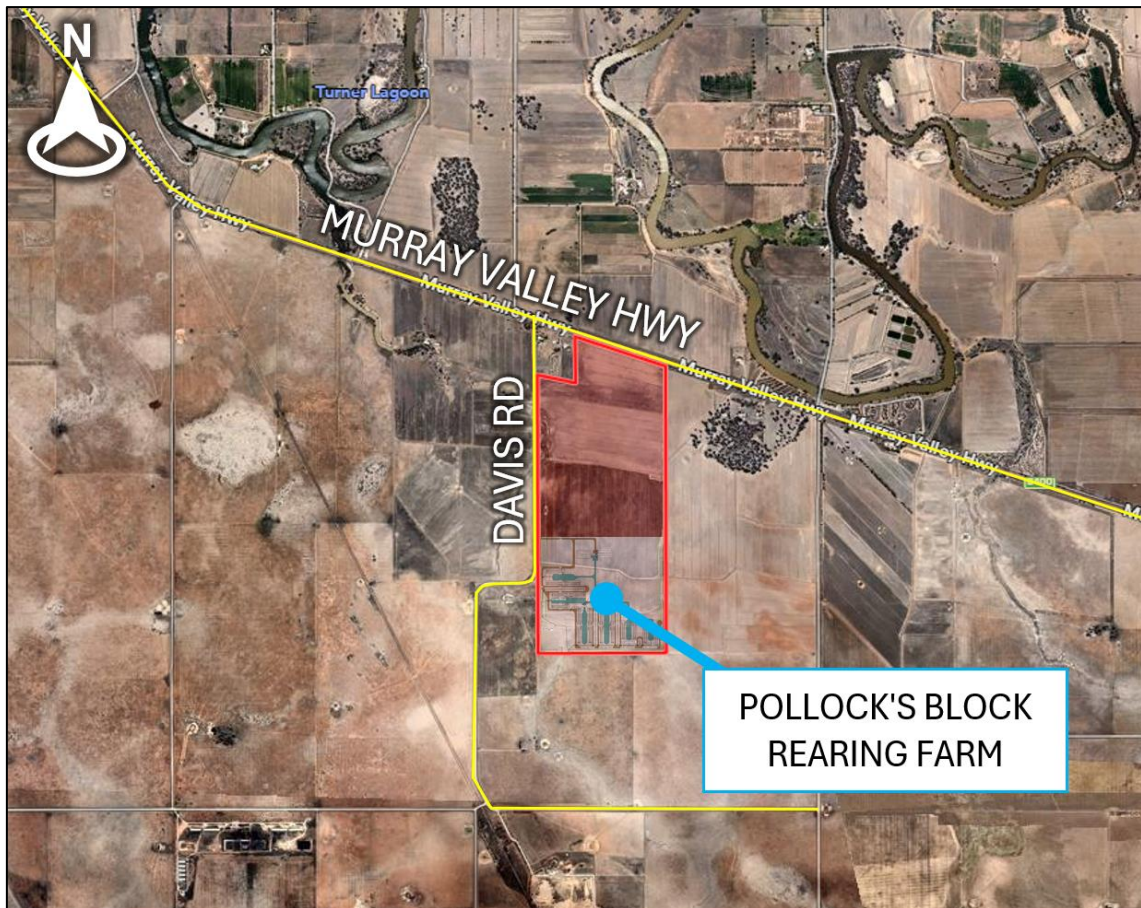

**Figure 2-2: Pollock's Block Rearing Farm site locality**

The proposed access to the Pollock's Block Rearing Farm is shown in **Figure 2-3**. The access is located approximately 20 m north of the existing farm access location and will provide access to the proposed poultry sheds (for chick delivery / collection, feed delivery and manure collection).

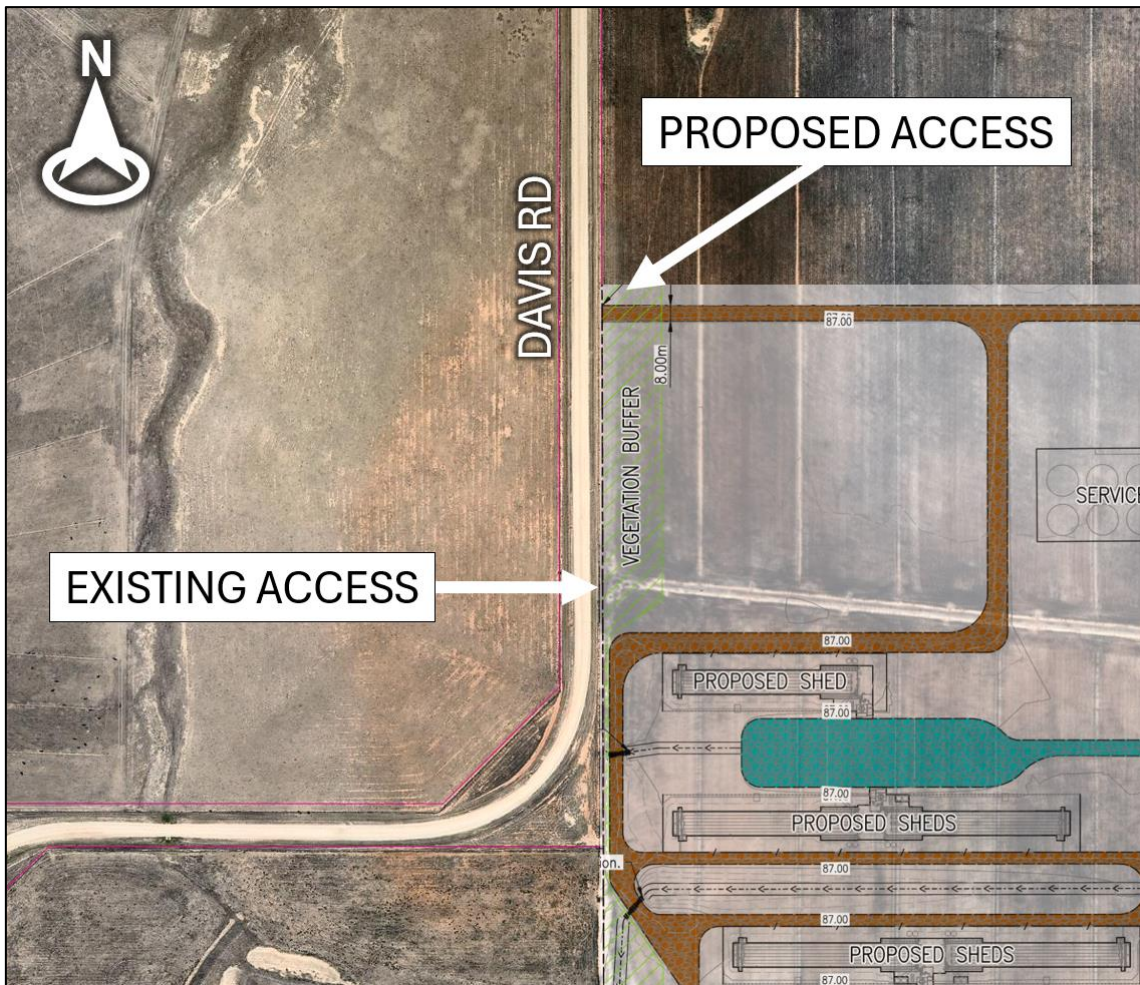

**Figure 2-3: Pollock's Block Rearing Farm site access**

### 2.1.3 Warwick's Block Cage-Free Layer Farm

The proposed Warwick's Block Cage-Free Layer Farm development is located on the Murray Valley Highway on land described by the following lots:

- Lot 16~7 on PP3663
- Lot 16A~7 on PP3663
- Lot 18~7 on PP3663
- Lot 19~7 on PP3663
- Lot 12~7 on PP3663
- Lot 12A~7 on PP3663
- Lot 2 on PS429220
- Unmade road reserve

The site is approximately 549.18ha in area and is located within the Farming Zone under the CSC Planning Scheme. The site is current farmland (cropping/grazing) and has minimal tree coverage. The property is bounded by the Murray Valley Highway along the southern boundary, Hepell Road along the eastern boundary, and Gunbower Creek to the north and west.

The Warwick's Block Cage-Free Layer Farm site locality is shown in **Figure 2-4**.

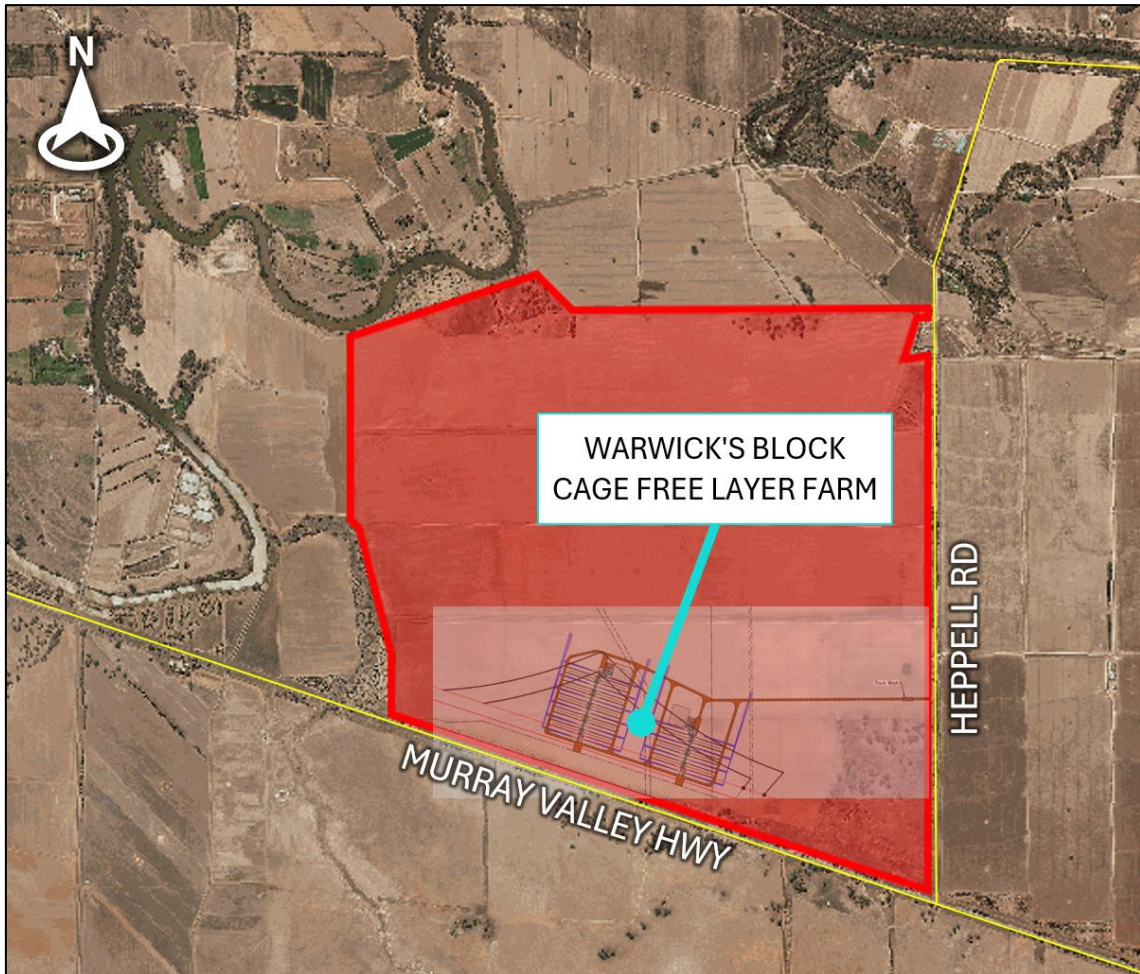

**Figure 2-4: Warwick's Block Cage-Free Layer Farm site locality**

The proposed access shown in **Figure 2-5** will be located approximately 800 m north of the Hoppel Road/Murray Valley Highway intersection and will provide access to the proposed poultry sheds (for pullet delivery / hen collection, feed delivery, egg collection and manure collection).

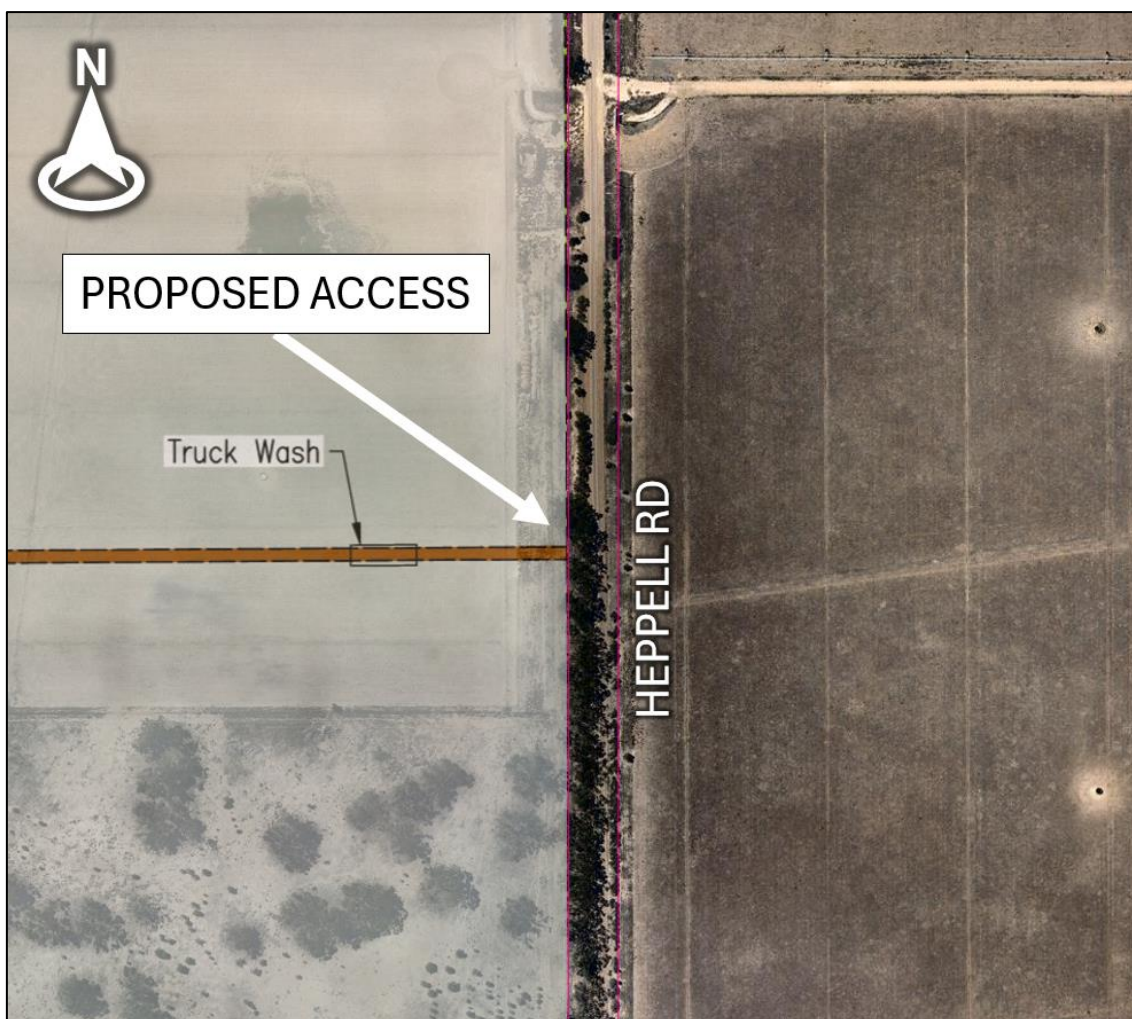

Figure 2-5: Warwick's Block Cage Free Layer Farm site access

#### 2.1.4 T-Block Free-Range Layer Farm and 'Organic Nutrients' Composting Facility

The proposed T-Block Free-Range Layer Farm and 'Organic Nutrients' Composting Facility is located on the Murray Valley Highway on land described by the following lots:

- Lot 1 on PS403267
- Lot 2 on PS403267
- Lot 1 on LP86931
- Lot 1 on PS547702
- Lot 2 on PS547702
- Lot 2 on PS404891
- Lot 23~3 on PP3663
- Lot 24~3 on PP3663
- Lot 18A~3 on PP3663

The site is approximately 1136.02ha in area and is located within the Farming Zone under the CSC Planning Scheme. The site is current farmland (cropping/grazing) and has minimal tree coverage. The development is bounded by the Murray Valley Highway to the north, Baillieu Road to the east and Roslynmead Road to the west.

The T-Block Free-Range Layer Farm and the 'Organic Nutrients' Composting Facility site locality is shown in **Figure 2-6**.

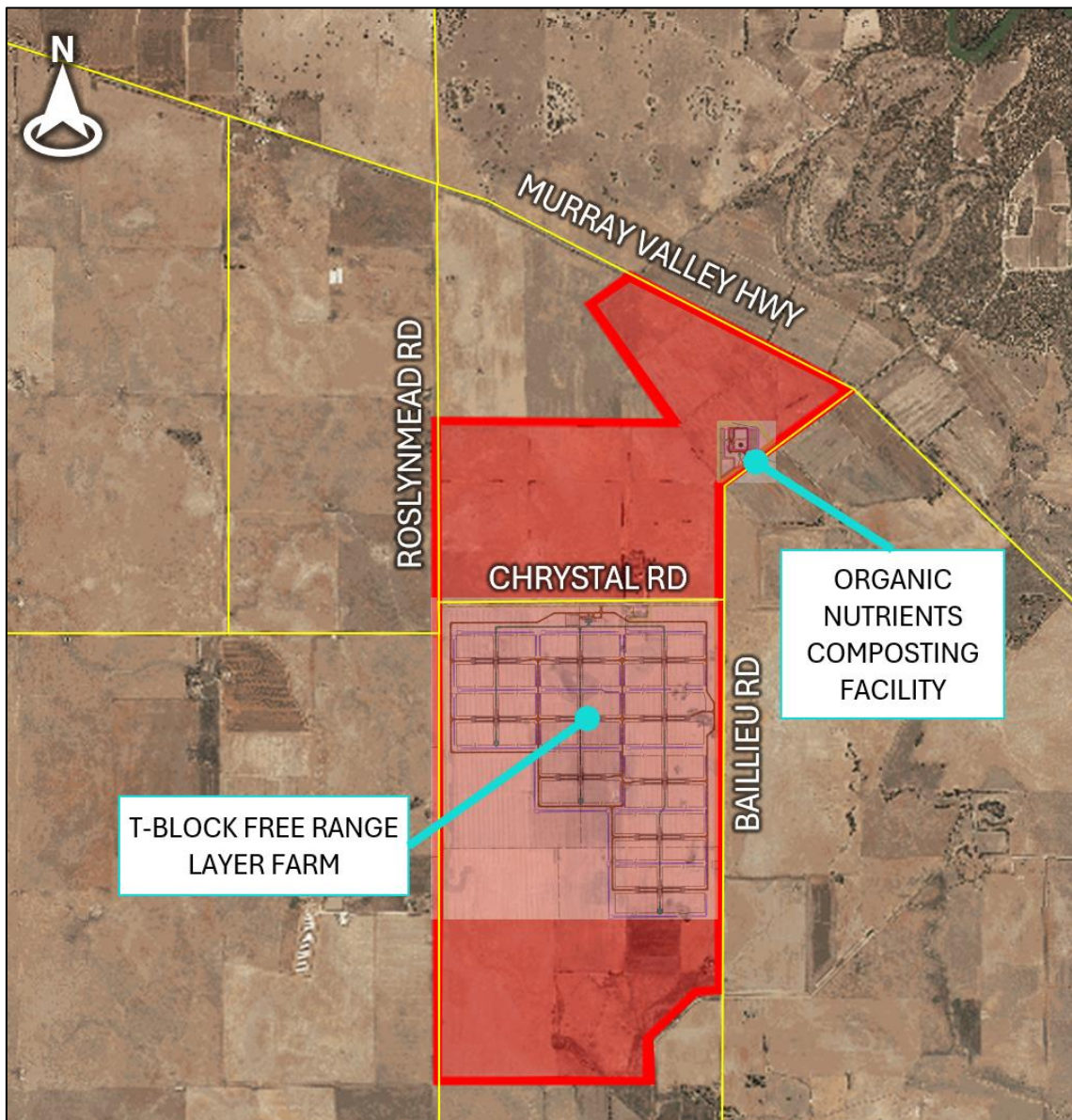

**Figure 2-6: T-Block Free-Range Layer Farm and 'Organic Nutrients' Composting Facility locality**

Access to the T-Block Free-Range Layer Farm is proposed via Chrystal Road, shown in **Figure 2-7**, which will provide access to the proposed poultry sheds (for pullet delivery / hen collection, feed delivery, egg collection and manure collection).

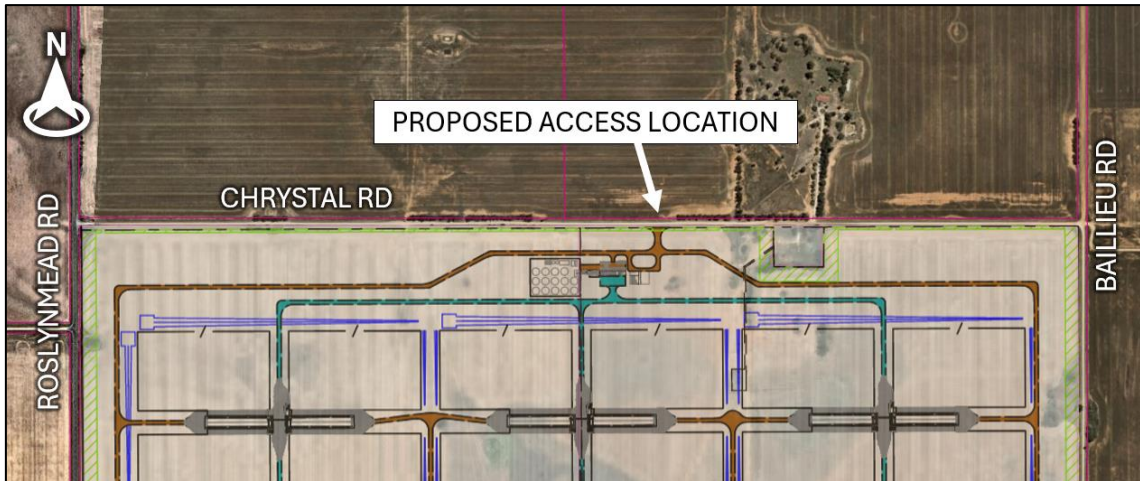

**Figure 2-7: T-Block Free Range Layer Farm site access**

Access to the 'Organic Nutrients' Composting Facility is proposed via Baillieu Road, approximately 1km north of the Baillieu Road / Chrystal Road intersection, as shown in **Figure 2-8**.

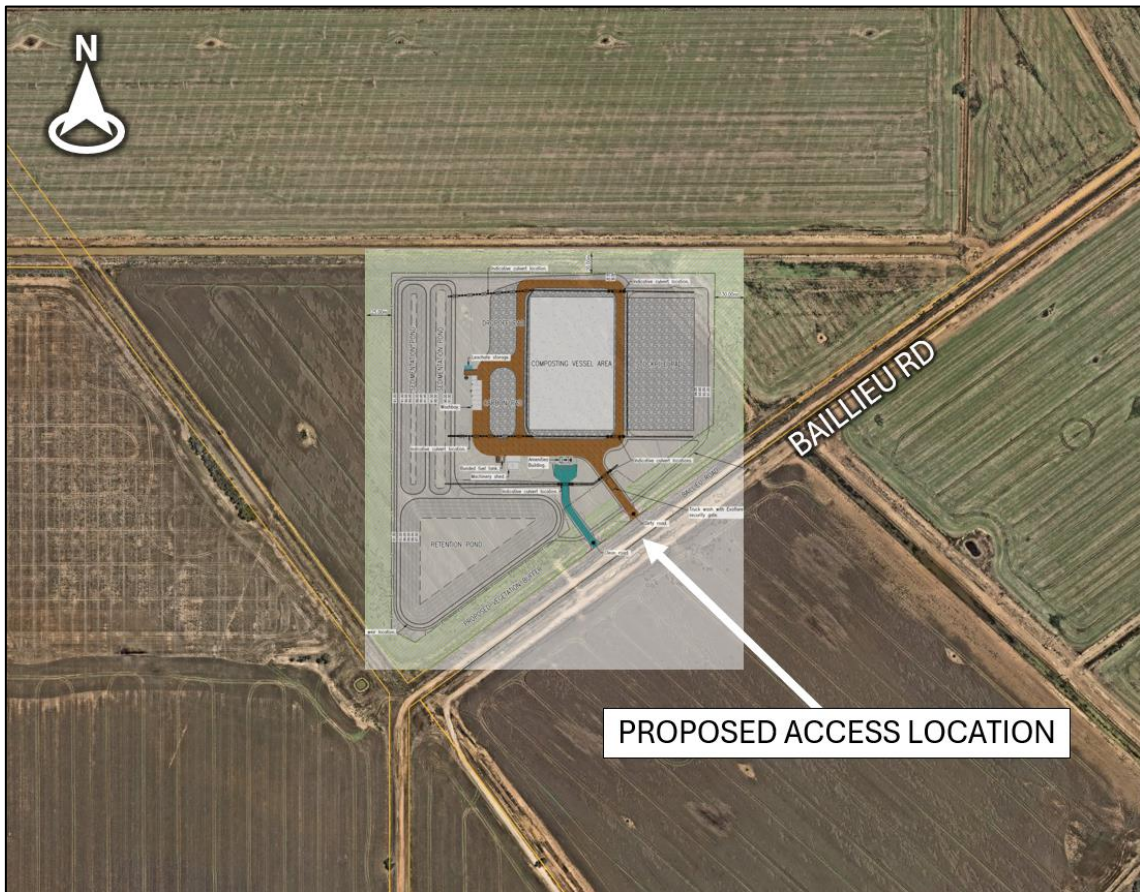

**Figure 2-8: 'Organic Nutrients' Composting Facility site access**

### 3. Development details

The proposed Integrated Egg Laying operation consists of the following sites:

- Pollock's Block Rearing Farm (720,000 birds),
- Warwick's Block Cage Free Layer Farm (1,280,000 birds),
- T-Block Free Range Layer Farm (800,000 birds) and,
- 'Organic Nutrients' Composting Facility.

The development will operate between the hours of 6am and 5pm, seven days a week. Relevant operational details of the farms are discussed below.

#### 3.1 Pollock's Block Rearing Farm

##### 3.1.1 Operational and staging details

The proposed development involves the construction of a new poultry rearing farm which is used for the rearing of laying birds from day-old chicks until they reach point-of-lay (around 17 weeks). At this age, the birds are collected from the farm and transferred to the Applicant's proposed egg laying farms also to be constructed within Torrumbarry. While being reared, the birds will be wholly contained within the proposed sheds at all times.

A maximum of 720,000 birds are proposed to be reared on the farm within 18 purpose built, best practice rearing sheds. These sheds will be delivered in two stages:

- Stage One: consisting of twelve sheds, commencing full operation in April 2028.
- Stage Two: consisting of six sheds, commencing full operation in January 2040.

The proposed sheds will be supported by ancillary services and infrastructure including a staff office and amenities building, workshop, water treatment, feed silos, and truck wash. The farm will also include construction of an access driveway connecting to Davis Road, internal driveways, parking and manoeuvring areas, and an extension of the electricity network.

##### 3.1.2 Expected traffic movements and design vehicles

Details regarding the vehicle movements associated with the Pollock's Block Rearing Farm development are provided below. It is noted that the information below considers the proposed ultimate form (i.e. all stages combined).

###### **Staff**

A total of 20 full time staff will be employed to carry out the site operations seven days a week.

The staff will arrive for their shift no later than 6am and leave the site when their shift ends, at approximately 2pm.

It is understood that staff members will travel to and from surrounding townships such as Echuca, Moama, Gunbower and Wharparilla in private (light) vehicles. As multiple staff may travel together, a carpooling rate of 10%-20% has been adopted for this assessment.

###### **Deliveries**

The deliveries to and from the site are expected to involve the following operational activities and associated vehicle movements:

- Chick delivery: One semi-trailer will deliver chicks to the development site once per fortnight (i.e. every two weeks). The semi-trailer will travel from Bendigo, Victoria. These deliveries are expected to occur on any given time and day between 7am to 1pm from Monday to Friday. The delivery can be arranged so that it doesn't coincide with any other deliveries or collections occurring on the site.
- Pullet collection: 21 semi-trailers will collect pullets from the development site every three weeks (over a one week period), totalling 364 loads per year. The semi-trailers will deliver the pullets to T-Block and Warwick's Block (associated laying farms). These deliveries are expected to occur on any given time and day between 6am to 4pm from Monday to Friday. Collections can be arranged so that it doesn't coincide with any other deliveries or collections occurring on the site.
- Feed delivery: Nine semi-trailers will deliver feed to the development site each week. The semi-trailers will travel from Colbinabbin. These deliveries are expected to occur between 7am to 5pm from Monday to Friday. The delivery can be arranged so that it doesn't coincide with any other deliveries or collections occurring on the site.
- Manure collection: 7 semi-trailers will deliver manure to the 'Organic Nutrients' Composting Facility each week. These deliveries are expected to occur between 6am to 4pm from Monday to Friday. The collection can be arranged so that it doesn't coincide with any other deliveries or collections occurring on the site.

**Table 3-1** and **Table 3-2** provide a summary of the anticipated daily development traffic volumes based on the operational details above.

Table 3-1: Expected traffic movements (staff) – Pollock’s Block Rearing Farm

Trip type	Arrival time	Departure time	Day(s)	No. of Staff	Origin / Destination	Traffic Generation	Average development traffic generation (ultimate scenario)		
							Estimated annual traffic generation (no. vehicles)	Estimated weekly traffic generation (no. vehicles)	Estimated daily traffic generation (no. vehicles)
Poultry staff	6-7am	3-4pm	Everyday	All Stages: 20 full time staff	Echuca/Moama/Gunbower/Wharparilla	All Stages: 18 vehicles per day, 7 days a week	6,552	126	18
<b>Total</b>							<b>6,552</b>	<b>126</b>	<b>18</b>

Table 3-2: Expected traffic movements and design vehicles (deliveries and collections) – Pollock’s Block Rearing Farm

Trip type	Arrival time	Departure time	Vehicle Type	Day(s)	Origin / Destination	Traffic Generation	Average development traffic generation (ultimate scenario)		
							Estimated annual traffic generation (no. vehicles)	Estimated weekly traffic generation (no. vehicles)	Estimated daily traffic generation (no. vehicles)
Chicks in	7am-1pm (varies)	7am-1pm (varies)	19m semi	Mon – Fri	Bendigo	All Stages: 1 vehicle, every 2 weeks	26	0.5	0.10
Pullet collection	6am-4pm (varies)	6am-4pm (varies)	19m semi	Mon – Fri	T-Block and Warwick’s Block Farms <i>NOTE: Truck is stationed at T-Block when not in use.</i>	All Stages: 21 vehicles over a week, every 3 weeks <i>Note: Trucks will arrive staggered over the course of one week.</i>	364	7	1.40
Feed delivery	7am-5pm (varies)	7am-5pm (varies)	19m semi	Mon – Fri	Colbinabbin	All Stages: 9 vehicles per week, every week	468	9	1.80
Manure collection	6am-4pm (varies)	6am-4pm (varies)	19m semi	Mon – Fri	‘Organic Nutrients’ Composting Facility <i>NOTE: Truck is stationed on-site when not in use.</i>	All Stages: 7 vehicles per week, every week	364	7	1.40
<b>Total</b>							<b>1,222</b>	<b>23.5</b>	<b>4.70</b>

From **Table 3-1** and **Table 3-2**, it is identified that the development will generate low daily traffic volumes, consisting of an average of five heavy vehicles and 18 light vehicles per day. This equates to a combined average of 46 vehicle trips per day (i.e. 23 vehicles per day).

## **3.2 Warwick's Block Cage-Free Layer Farm**

### **3.2.1 Operational and staging details**

The proposed development involves the construction of a new poultry layer farm which is used for production of eggs intended for human consumption. The proposed farm will accommodate a maximum of 1,280,000 layer birds within 16 purpose built, best practice layer sheds. These sheds will be delivered in two stages:

- Stage One: consisting of eight sheds, commencing full operation in April 2028.
- Stage Two: consisting of eight sheds, commencing full operation in January 2040.

The areas of the subject site outside of the proposed poultry farm will continue to be used for cropping purposes.

The proposed sheds will be supported by ancillary services and infrastructure including a staff office and amenities building, egg collection infrastructure and holding rooms, workshop, water treatment, feed silos and truck wash. The farm will also include construction of an access driveway connecting to Heppell Road, internal driveways, parking and manoeuvring areas, and an extension of the electricity network. Water supply will be provided by extension of the existing arrangements and licenses servicing the site.

The proposed farm will house layer birds that are placed within the sheds at around 17 weeks of age. Once placed the typical laying cycle will last for around 68 weeks, including 66 weeks of production, and 2 weeks of down time allocated for shed cleaning, and set up prior to the next batch. As a cage free farm, the birds will be free to move around but will always be contained within the sheds.

### **3.2.2 Expected traffic movements and design vehicles**

Details regarding the vehicle movements associated with the Warwick's Block Cage Free Layer Farm development are provided below. It is noted that the information below considers the proposed ultimate form (i.e. all stages combined).

#### **Staff**

A total of 44 full time staff will be employed to carry out the site operations seven days a week.

The staff will arrive for their shift no later than 6am and leave the site when their shift ends, at approximately 2pm.

It is understood that staff members will travel to and from surrounding townships such as Echuca, Moama, Gunbower and Wharparilla in private (light) vehicles. As multiple staff may travel together, a carpooling rate of 10%-20% has been adopted for this assessment.

### ***Deliveries***

The deliveries to and from the site are expected to involve the following operational activities and associated vehicle movements:

- Pullet delivery: 18 semi-trailer's will deliver pullets to the development site every three weeks (during a one week period). The semi-trailer's will travel from Pollock's Block Rearing Farm. These deliveries are expected to occur on any given time and day between 6am to 4pm from Monday to Friday. The delivery can be arranged so that it doesn't coincide with any other deliveries or collections occurring on the site.
- Hen collection: Seven semi-trailer loads will be required to collect hens from each shed at the end of each cycle. It is anticipated that 24 sheds will be serviced per year, totalling 168 loads per year. The semi-trailers will deliver the hens to the 'Organic Nutrients' Composting Facility. These collections / deliveries are expected to occur between 7pm to 3am from Monday to Friday.
- Feed delivery: 48 semi-trailers will deliver feed to the development site each week. The semi-trailers will travel from Colbinabbin. These deliveries are expected to occur between 6am to 5pm from Monday to Friday. The delivery can be arranged so that it doesn't coincide with any other deliveries or collections occurring on the site.
- Egg collection: 6 semi-trailers will collect eggs from the development site each day. The semi-trailers will travel to/from Merrifield. These deliveries are expected to occur between 6am to 4pm from Monday to Friday. The collection can be arranged so that it doesn't coincide with any other deliveries or collections occurring on the site.
- Manure collection: 24 semi-trailers will deliver manure to the 'Organic Nutrients' Composting Facility each week. These deliveries are expected to occur between 6am to 4pm from Monday to Friday. The delivery can be arranged so that it doesn't coincide with any other deliveries or collections occurring on the site.

**Table 3-3** and **Table 3-4** provide a summary of the anticipated daily development traffic volumes based on the operational details above.

**Table 3-3: Expected traffic movements (staff) – Warwick’s Block Cage Free Layer Farm**

Trip type	Arrival time	Departure time	Day(s)	No. of Staff	Origin / Destination	Traffic Generation	Average development traffic generation (ultimate scenario)		
							Estimated annual traffic generation (no. vehicles)	Estimated weekly traffic generation (no. vehicles)	Estimated daily traffic generation (no. vehicles)
<b>Poultry staff</b>	5-6am	2-3pm	Everyday	<b>All Stages:</b> 44 full time staff	Echuca/Moama/Gunbower/Wharparilla	<b>All Stages:</b> 40 vehicles per day, 7 days a week	14,560	280	40
<b>Total</b>							<b>14,560</b>	<b>280</b>	<b>40</b>

**Table 3-4: Expected traffic movements and design vehicles (deliveries and collections) – Warwick’s Block Cage Free Layer Farm**

Trip type	Arrival time	Departure time	Vehicle Type	Day(s)	Origin / Destination	Traffic Generation	Average development traffic generation (ultimate scenario)		
							Estimated annual traffic generation (no. vehicles)	Estimated weekly traffic generation (no. vehicles)	Estimated daily traffic generation (no. vehicles)
<b>Pullet delivery</b>	6am-4pm (varies)	6am-4pm (varies)	19m semi	Mon – Fri	Pollock’s Block Rearing Farm <i>NOTE: Truck is stationed at T-Block when not in use.</i>	<b>All Stages:</b> 18 vehicles, every 3 weeks	312	6	1.20
<b>Hen collection</b>	7pm-3am (varies)	7pm-3am (varies)	19m semi	Mon – Fri	‘Organic Nutrients’ Composting Facility <i>NOTE: Truck is stationed at T-Block when not in use.</i>	<b>All Stages:</b> 168 vehicles per year <i>Note: Hens are removed over the course of 2 days. 24 sheds x 7 loads = 168 trips removed over 2 days.</i>	168	3.2	0.65
<b>Feed delivery</b>	6am-5pm (varies)	6am-5pm (varies)	19m semi	Mon – Fri	Colbinabbin	<b>All Stages:</b> 48 vehicles per week, every week	2,496	48	9.60
<b>Egg collection</b>	6am-4pm (varies)	6am-4pm (varies)	19m semi	Every day	Merrifield	<b>All Stages:</b> 6 vehicles per day, 7 days a week	2,184	42	6.00
<b>Manure collection</b>	6am-4pm (varies)	6am-4pm (varies)	19m semi	Mon – Fri	‘Organic Nutrients’ Composting Facility <i>NOTE: Truck is stationed on-site when not in use.</i>	<b>All Stages:</b> 24 vehicles per week, every week	1,248	24	4.80
<b>Total</b>							<b>6,408</b>	<b>123.2</b>	<b>22.25</b>

From **Table 3-3** and **Table 3-4**, it is identified that the development will generate an average of 22 heavy vehicles and 40 light vehicles per day. This equates to a combined average of 124 vehicle trips per day (i.e. 62 vehicles per day).

### 3.3 T-Block Free Range Layer Farm

#### 3.3.1 Operation and staging details

The proposed development involves the construction of a new poultry layer farm which is used for production of eggs intended for human consumption. The proposed farm will accommodate a maximum of 800,000 layer birds within 20 purpose built, best practice layer sheds. These sheds will be constructed in 2 stages:

- Stage One: consisting of 10 sheds, commencing full operation in April 2028.
- Stage Two: consisting of 10 sheds, commencing full operation in January 2042.

The areas of the subject site outside of the proposed poultry farm will continue to be used for cropping purposes.

The proposed sheds will be supported by ancillary services and infrastructure including a staff office and amenities building, egg collection infrastructure and holding rooms, workshop, water treatment, feed silos, truck wash, perimeter fencing, and internal range areas. The farm will also include construction of an access driveway connecting to Baillieu Road, internal driveways, parking and manoeuvring areas, and an extension of the electricity network. Water supply will be provided by extension of the existing arrangements and licenses servicing the site.

The proposed farm will house layer birds that are placed within the sheds at around 17 weeks of age. Once placed the typical laying cycle will last for around 68 weeks, including 66 weeks of production, and 2 weeks of down time allocated for shed cleaning, and set up prior to the next batch. The farm is intended to operate as a free-range layer farm whereby the birds are provided with daily access to the range areas. However, the sheds will be constructed to allow them to operate as free range or cage free sheds as required.

#### 3.3.2 Expected traffic movements and design vehicles

Details regarding the vehicle movements associated with the T-Block Free Range Layer Farm development are provided below. It is noted that the information below considers the proposed ultimate form (i.e. all stages combined).

##### **Staff**

A total of 48 full time staff will be employed to carry out the site operations seven days a week,

The staff will arrive for their shift no later than 6am and leave the site when their shift ends, at approximately 2pm.

It is understood that staff members will travel to and from surrounding townships such as Echuca, Moama, Gunbower and Wharparilla in private (light) vehicles. As multiple staff may travel together, a carpooling rate of 10%-20% has been adopted for this assessment.

### **Deliveries**

The deliveries to and from the site are expected to involve the following operational activities and associated vehicle movements:

- Pullet delivery: 10 semi-trailer's will deliver pullets to the development site every three weeks (during one week). The semi-trailer's will travel from Pollock's Block Rearing Farm. These deliveries are expected to occur on any given time and day between 6am to 4pm from Monday to Friday. The delivery can be arranged so that it doesn't coincide with any other deliveries or collections occurring on the site.
- Hen collection: Seven semi-trailer loads will be required to collect hens from each shed at the end of each cycle. It is anticipated that 16 sheds will be serviced per year, totalling 112 loads per year. The semi-trailers will deliver the hens to the 'Organic Nutrients' Composting Facility. These collections / deliveries are expected to occur between 7pm to 3am from Monday to Friday.
- Feed delivery: 30 semi-trailers will deliver feed to the development site each week. The semi-trailers will travel from Colbinabbin. These deliveries are expected to occur between 6am to 5pm from Monday to Friday. The delivery can be arranged so that it doesn't coincide with any other deliveries or collections occurring on the site.
- Egg collection: Four semi-trailers will collect eggs from the development site each day. The semi-trailers will travel to/from Merrifield. These deliveries are expected to occur between 6am to 5pm from Monday to Friday. The delivery can be arranged so that it doesn't coincide with any other deliveries or collections occurring on the site.
- Manure collection: 14 semi-trailers will deliver manure to the 'Organic Nutrients' Composting Facility each week. These deliveries are expected to occur between 6am to 4pm from Monday to Friday. The delivery can be arranged so that it doesn't coincide with any other deliveries or collections occurring on the site.

**Table 3-5** and **Table 3-6** provide a summary of the anticipated daily development traffic volumes based on the operational details above.

**Table 3-5: Expected traffic movements (staff) – T-Block Free Range Layer Farm**

Trip type	Arrival time	Departure time	Day(s)	No. of Staff	Origin / Destination	Traffic Generation	Average development traffic generation (ultimate scenario)		
							Estimated annual traffic generation (no. vehicles)	Estimated weekly traffic generation (no. vehicles)	Estimated daily traffic generation (no. vehicles)
<b>Poultry staff</b>	5-6am	2-3pm	Everyday	<b>All Stages:</b> 48 full time staff	Echuca/Moama/Gunbower/Wharparilla	<b>All Stages:</b> 44 vehicles per day, 7 days a week	16,016	308	44
<b>Total</b>							<b>16,016</b>	<b>308</b>	<b>44</b>

**Table 3-6: Expected traffic movements and design vehicles (deliveries and collections) – T-Block Free Range Layer Farm**

Trip type	Arrival time	Departure time	Vehicle Type	Day(s)	Origin / Destination	Traffic Generation	Average development traffic generation (ultimate scenario)		
							Estimated annual traffic generation (no. vehicles)	Estimated weekly traffic generation (no. vehicles)	Estimated daily traffic generation (no. vehicles)
<b>Pullet delivery</b>	6am-4pm (varies)	6am-4pm (varies)	19m semi	Mon – Fri	Pollock's Block Rearing Farm <i>NOTE: Truck is stationed at T-Block when not in use.</i>	<b>All Stages:</b> 10 vehicles, every 3 weeks	174	3.3	0.67
<b>Hen collection</b>	7pm-3am (varies)	7pm-3am (varies)	19m semi	Mon – Fri	'Organic Nutrients' Composting Facility <i>NOTE: Truck is stationed at T-Block when not in use.</i>	<b>All Stages:</b> 112 vehicles per year	112	2.15	0.43
<b>Feed delivery</b>	6am-5pm (varies)	6am-5pm (varies)	19m semi	Mon – Fri	Colbinabbin	<b>All Stages:</b> 30 vehicles per week, every week	1,560	30	6.00
<b>Egg collection</b>	6am-4pm (varies)	6am-4pm (varies)	19m semi	Every day	Merrifield	<b>All Stages:</b> 4 vehicles per day, 7 days a week	1,456	28	4.00
<b>Manure collection</b>	6am-4pm (varies)	6am-4pm (varies)	19m semi	Mon – Fri	'Organic Nutrients' Composting Facility <i>NOTE: Trucks is stationed on-site when not in use.</i>	<b>All Stages:</b> 14 vehicles per week, every week	728	14	2.80
<b>Total</b>							<b>4,030</b>	<b>77.5</b>	<b>13.90</b>

From **Table 3-5** and **Table 3-6**, it is identified that the development will generate an average of 14 heavy vehicles and 44 light vehicles per day. This equates to a combined average of 116 vehicle trips per day (i.e. 58 vehicles per day).

### 3.4 Organic Nutrients Composting Facility

#### 3.4.1 Operational details and staging

The T-Block Free Range Layer Farm development application also includes an ancillary composting facility located on Lot 2 on PS404891. This 'Organic Nutrients' Composting Facility is located directly to the north-east of T-Block Free Range Layer Farm and will be sized to accept manure and floor litter directly from the poultry farms (T-Block, Warwick's Block and Pollock's Block) which is then composted to create a soil conditioner and fertilizer product which will be used for own use off site.

#### 3.4.2 Expected traffic movements and design vehicles

Details regarding the vehicle movements associated with the Organic Nutrients Composting Facility development are provided below. It is noted that the information below considers the proposed ultimate form (i.e. all stages combined).

##### **Staff**

A total of five full time staff will be employed to carry out the site operations seven days a week. The staff travelling to and from the site will arrive for their shift at approximately 7am and leave the site when their shift ends, at approximately 3pm.

It is understood that all staff members will travel to and from surrounding townships such as Echuca, Moama, Gunbower and Wharparilla in private (light) vehicles. It is noted that multiple staff may travel in the same light vehicle, however for a conservative assessment it has been assumed that each staff member will travel separately.

##### **Deliveries**

The deliveries to and from the site are expected to involve the following operational activities and associated vehicle movements:

- **Carbon source:** Nine semi-trailers will deliver carbon source to the development site every week. The semi-trailers will travel from various locations within Victoria. These deliveries are expected to occur on any given time and day between 6am to 4pm from Monday to Friday. The delivery can be arranged so that it doesn't coincide with any other deliveries or collections occurring on the site.
- **Manure delivery:** 45 semi-trailers will deliver manure from the other farm sites (Pollock's Block, Warwick's Block, T-Block) each week. These deliveries are expected to occur on any given time and day between 6am to 4pm from Monday to Friday. The delivery can be arranged so that it doesn't coincide with any other deliveries or collections occurring on the site.
- **Composting:** 29 semi-trailers will deliver compost to other farm sites (Warwick's Block and T-Block) each week. These deliveries are expected to occur on any given time and day between 6am to 4pm from Monday to Friday. The delivery can be arranged so that it doesn't coincide with any other deliveries or collections occurring on the site.

**Table 3-7** and **Table 3-8** provide a summary of the anticipated daily development traffic volumes based on the operational details above.

**Table 3-7: Expected traffic movements (staff) – Organic Nutrients composting Facility**

Trip type	Arrival time	Departure time	Day(s)	No. of Staff	Origin / Destination	Traffic Generation	Average development traffic generation (ultimate scenario)		
							Estimated annual traffic generation (no. vehicles)	Estimated weekly traffic generation (no. vehicles)	Estimated daily traffic generation (no. vehicles)
Composting Facility staff	6-7am	3-4pm	Everyday	All Stages: 5 full time staff	Echuca/Moama/Gunbower/Wharparilla	All Stages: 5 vehicles per day, 5 days a week	1,300	25	5
<b>Total</b>							<b>1,300</b>	<b>25</b>	<b>5</b>

**Table 3-8: Expected traffic movements and design vehicles (deliveries and collections) - Organic Nutrients composting Facility**

Trip type	Arrival time	Departure time	Vehicle Type	Day(s)	Origin / Destination	Traffic Generation	Average development traffic generation (ultimate scenario)		
							Estimated annual traffic generation (no. vehicles)	Estimated weekly traffic generation (no. vehicles)	Estimated daily traffic generation (no. vehicles)
Carbon source	6am-4pm (varies)	6am-4pm (varies)	19m semi	Mon – Fri	Various	All Stages: 9 vehicles per week, every weeks	468	9	1.80
Manure delivery	6am-4pm (varies)	6am-4pm (varies)	19m semi	Mon – Fri	Pollock’s Block, Warwick’s Block and T-Block Farms	All Stages: 45 vehicles per week, every week	2,340 <sup>1</sup>	45 <sup>1</sup>	9.00 <sup>1</sup>
Composting	6am-4pm (varies)	6am-4pm (varies)	19m semi	Mon – Fri	Warwick’s Block T-Block	All Stages: 29 vehicles per week, every week	1,508	29	5.80
<b>Total</b>							<b>4,316</b>	<b>83</b>	<b>16.60</b>

<sup>1</sup> These movements are already accounted for in each of the farm generation tables above (Table 3-2, Table 3-4 and Table 3-6)

From **Table 3-7** and **Table 3-8**, it is identified that the development will generate low daily traffic volumes, consisting of an average of 17 heavy vehicles and 5 light vehicles per day. This equates to a combined average of 44 vehicle trips per day (i.e. 22 vehicles per day).

### 3.5 Summary

**Table 3-9** summarises the estimated daily traffic generation for the development as a whole.

**Table 3-9: Estimated daily traffic generation summary – total development (all sites)**

Site	Estimated daily traffic generation (no. vehicles)	
	Staff	Heavy vehicles
Pollock's Block Rearing Farm	18	5.7
Warwick's Block Cage Free Layer Farm	40	21.9
T-Block Free Range Layer Farm	44	13.9
'Organic Nutrients' Composting Facility	5	7.6 <sup>1</sup>
<b>Total</b>	<b>107</b>	<b>48.5</b>

<sup>1</sup>A total of 9 vehicle trips have been excluded from the composting site's heavy vehicle trip count, as these trips are already accounted for within the respective farm heavy vehicle traffic volumes presented in this table.

As indicated above, the development as a whole is expected to generate 107 light vehicles and 49 heavy vehicles per day. These vehicles will be dispersed between the four sites, and the arrival/departure of heavy vehicles will be distributed throughout the day.

The maximum number of vehicles proposed to enter and exit the development site per hour are associated with staff vehicle movements as the heavy vehicle movements is distributed evenly throughout the day.

#### 3.5.1 Servicing and visitors

In addition to the above, the proposed development sites are expected to have other ad-hoc trips associated with servicing (such as maintenance, contractors and small deliveries), as well as visitors. On average, these volumes are expected to be low in comparison with the operation of the sites and will occur so that they don't coincide with any other deliveries or peak hours. Because of this, these types of trips have not been included in the assessment.

#### 3.5.2 Waste and refuse collection

It is anticipated that there will be a number of additional heavy vehicles associated with waste collection at each of the development sites. All solid waste not being transferred to the composting facility (i.e. general refuse and cardboard) will be transported via a refuse collection vehicle (10.5m long rigid vehicle) to an approved waste disposal facility by a licensed contractor. General waste will be transported to the Veolia Patho Landfill site on Davis Road (to the south of the Pollock's Block Rearing Farm), and cardboard will be transported to a sorting/recycling facility in Echuca. The expected waste collection details for the total development (all stages) are outlined in the **Table 3-10** below.

**Table 3-10: Estimated waste collection traffic generation**

Site	Estimated refuse collection vehicle traffic generation	
	Weekly (no. vehicles)	Daily (no. vehicles)
<b>Pollock's Block Rearing Farm</b>	1 (general refuse) 1 (cardboard/recyclables)	0.2 (general refuse) 0.2 (cardboard/recyclables)
<b>Warwick's Block Cage Free Layer Farm</b>	1 (general refuse) 1 (cardboard/recyclables)	0.2 (general refuse) 0.2 (cardboard/recyclables)
<b>T-Block Free Range Layer Farm</b>	1 (general refuse) 1 (cardboard/recyclables)	0.2 (general refuse) 0.2 (cardboard/recyclables)
<b>'Organic Nutrients' Composting Facility</b>	1 (general refuse)	0.2 (general refuse)
<b>Total</b>	<b>4 (general refuse)</b> <b>3 (cardboard/recyclables)</b>	<b>0.8 (general refuse)</b> <b>0.6 (cardboard/recyclables)</b>

The waste collection traffic can be managed to occur during off-peak periods within normal business hours, from Monday to Friday. The average number of daily trips generated by the waste collection is deemed minimal with less than one vehicle for general waste collection and less than one vehicle for cardboard collection per day. Because of this, the waste collection trips have not been included in the assessment as they will not impact upon the peak hour assessment periods discussed in **Section 4.5.5**.

## 4. Existing transport environment

### 4.1 Surrounding road network

The primary traffic network providing access to the subject sites is via the following roads:

- Murray Valley Highway (all sites)
- Roslynmead Road
- Heppell Road
- Davis Road
- Chrystal Road
- Baillieu Road

The primary traffic network is shown in **Figure 4-1**. The specific travel routes associated with each site is provided in **Appendix B**.

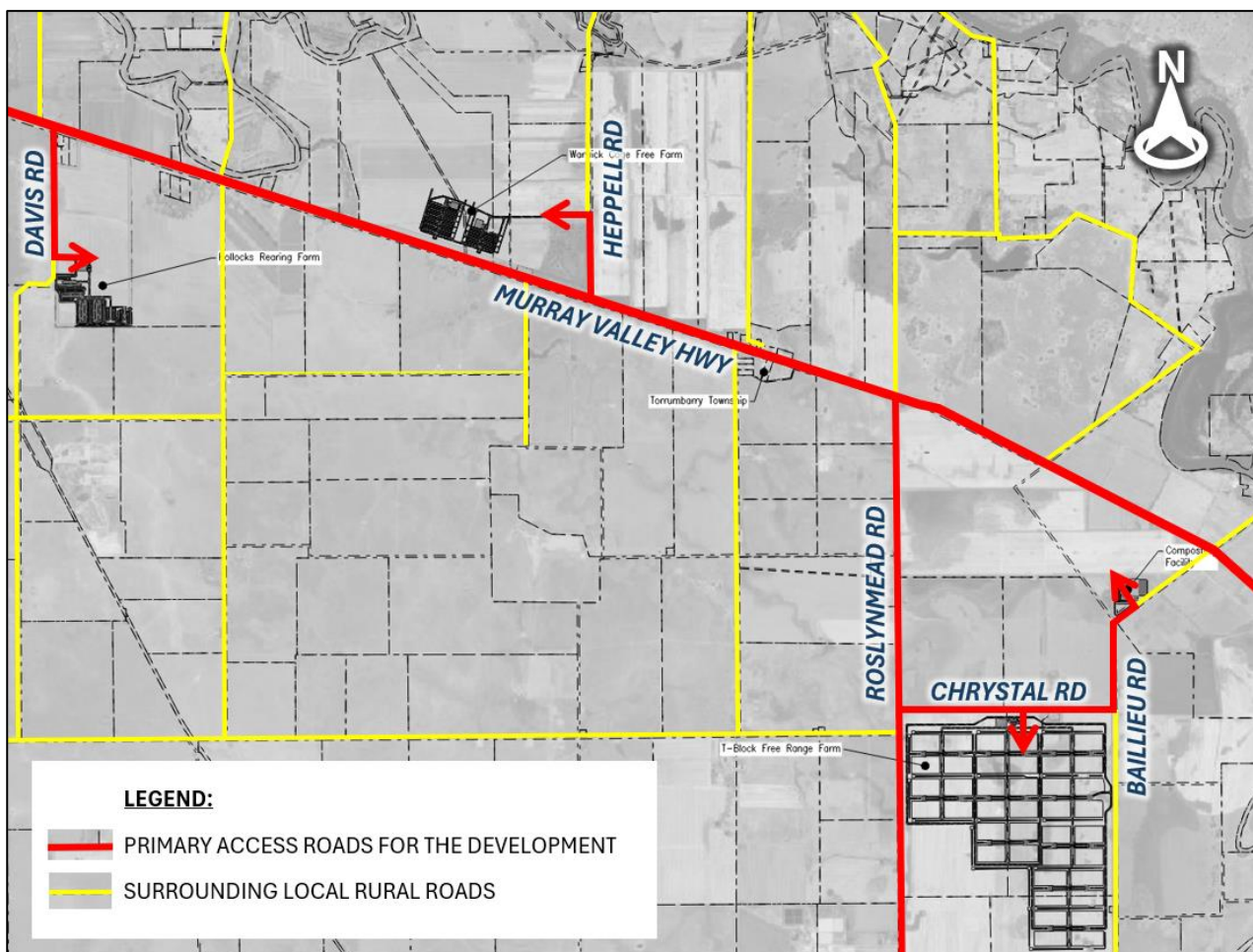

**Figure 4-1: Primary access roads**

The key roads and intersections are discussed further in the following sections.

## 4.2 Key roads

### 4.2.1 Murray Valley Highway

The Murray Valley Highway is a State Controlled Arterial Road (SCR) under the Victorian Planning Scheme.

The highway predominantly follows the state border line of Victoria (VIC) and New South Wales (NSW) between Euston, NSW in the west and Corryong, VIC in the east (approximately 663 kilometres in length).

Within the vicinity of the subject sites, the Murray Valley Highway has the following characteristics (refer **Figure 4-2**):

- Two-way, two-lane configuration
- Sealed carriageway width of approximately 9-10m
- 3.5m wide lanes
- 1.5m wide shoulders
- Road reserve width of 60m
- Posted speed limit of 100km/h
- 2025 daily traffic volumes of approximately 3,500 vehicles per day (vpd)



**Figure 4-2: Murray Valley Highway (facing east from Davis Road)**

#### 4.2.2 Roslynmead Road

Roslynmead Road runs predominantly north-south and connects the Murray Valley Highway in the north with Mount Terrick Road in the south. It is classified as a Collector – Rural road, as per the CSC *Register of Public Roads*.

Within the vicinity of the subject sites, Roslynmead Road has the following characteristics (refer **Figure 4-3**):

- Two-way, two-lane configuration
- Sealed carriageway width of approximately 6.5 m
- 3.3m wide lanes
- Gravel/grassed shoulders
- Road reserve width of 20 m
- Unsigned rural default speed limit (100 km/h)
- 2025 daily traffic volumes of approximately 340 vpd



**Figure 4-3: Roslynmead Road (looking south from the Murray Valley Highway)**

### 4.2.3 Heppell Road

Heppell Road runs predominantly north-south and connects National Channel Road in the north with the Murray Valley Highway in the south. It is classified as an earth Access Rural Road in the vicinity of the subject site, as per the *CSC Register of Public Roads*.

In the vicinity of the subject site, Heppell Road has the following characteristics (refer to **Figure 4-4**):

- Two-way, undivided configuration
- 5m wide earth Access Rural Road
- Traversable grassed verges (varying between 1 m to 5 m)
- Road reserve width of approximately 20 m
- Unsigned rural default speed limit (100 km/h)
- Traffic counts of 17vpd at 20% CV (information supplied by CSC in September 2025)



**Figure 4-4: Heppell Road (facing north from the Murray Valley Highway)**

#### 4.2.4 Davis Road

Davis Road is a two-way undivided road that runs predominantly north- south and connects the Murray Valley Highway in the north with Mount Terrick Road in the south. It is classified as an Access Rural Road, as per the CSC *Register of Public Roads*.

Davis Road provides access to the Veolia Patho Landfill site to the south of the proposed Pollock's Block Rearing Farm site. Davis Road experiences a high proportion of heavy vehicle traffic associated with the landfill site.

In the vicinity of the subject site, Davis Road has the following characteristics (refer to **Figure 4-5**):

- Two-way configuration
- Partially sealed carriageway (sealed approximately 300 m from the Murray Valley Highway) with a sealed pavement width varying between approximately 4-6 m, and gravel shoulders ranging between 1-3 m
- Approximately 7-10 m unsealed gravel carriageway continuing to the south of the paved section
- Traversable verges (varying between 1-5 m)
- No line marking
- Road reserve width of approximately 20 m
- Unsigned rural default speed limit (100 km/h)
- 2025 daily traffic volumes of approximately 110vpd (with 75% heavy vehicle proportion)



**Figure 4-5: Davis Road (looking south from the Murray Valley Highway)**

#### 4.2.5 Chrystal Road

Chrystal Road is a two-way undivided road that runs predominantly east-west and connects Baillieu Road in the east with Roslynmead Road in the west. It is classified as a gravel/unsealed Collector Road, as per the *CSC Register of Public Roads*.

In the vicinity of the subject site, Chrystal Road has the following characteristics (refer to **Figure 4-6**):

- Two-way configuration
- Unsealed gravel/dirt carriageway width varying between approximately 4-6 m
- Traversable verges (varying between 1-5 m)
- Road reserve width of approximately 18 m
- Unsigned rural default speed limit (100 km/h)
- Traffic counts of 10vpd at 15% CV (information supplied by CSC in September 2025)



**Figure 4-6: Chrystal Road (looking east from Roslynmead Road)**

#### 4.2.6 Baillieu Road

Baillieu Road is a two-way undivided road that runs predominantly north-south and intersects the Murray Valley Highway in the north with Reserve Road in the south. It is classified as an earth Access Rural Road, as per the CSC *Register of Public Roads*.

In the vicinity of the subject site, Baillieu Road has the following characteristics (refer to **Figure 4-7**):

- Two-way configuration
- Unsealed gravel/dirt carriageway width varying between approximately 4-6 m
- Dry weather road unsealed pavement
- Traversable verges (varying between 1 m to 10 m)
- Road reserve width of approximately 18 m
- Unsigned rural default speed limit (100 km/h)
- Traffic counts of 5vpd (information supplied by CSC in September 2025)



**Figure 4-7: Baillieu Road (looking southwest from Murray Valley Highway)**

### 4.3 Key intersections

The following key intersections are located near and most relevant to the site:

- Murray Valley Highway / Roslynmead Road / Bail Road
- Murray Valley Highway / Heppell Road
- Murray Valley Highway / Davis Road
- Roslynmead Road / Chrystal Road
- Baillieu Road / Chrystal Road

These intersections are shown on **Figure 4-8** and are detailed further the following sections.

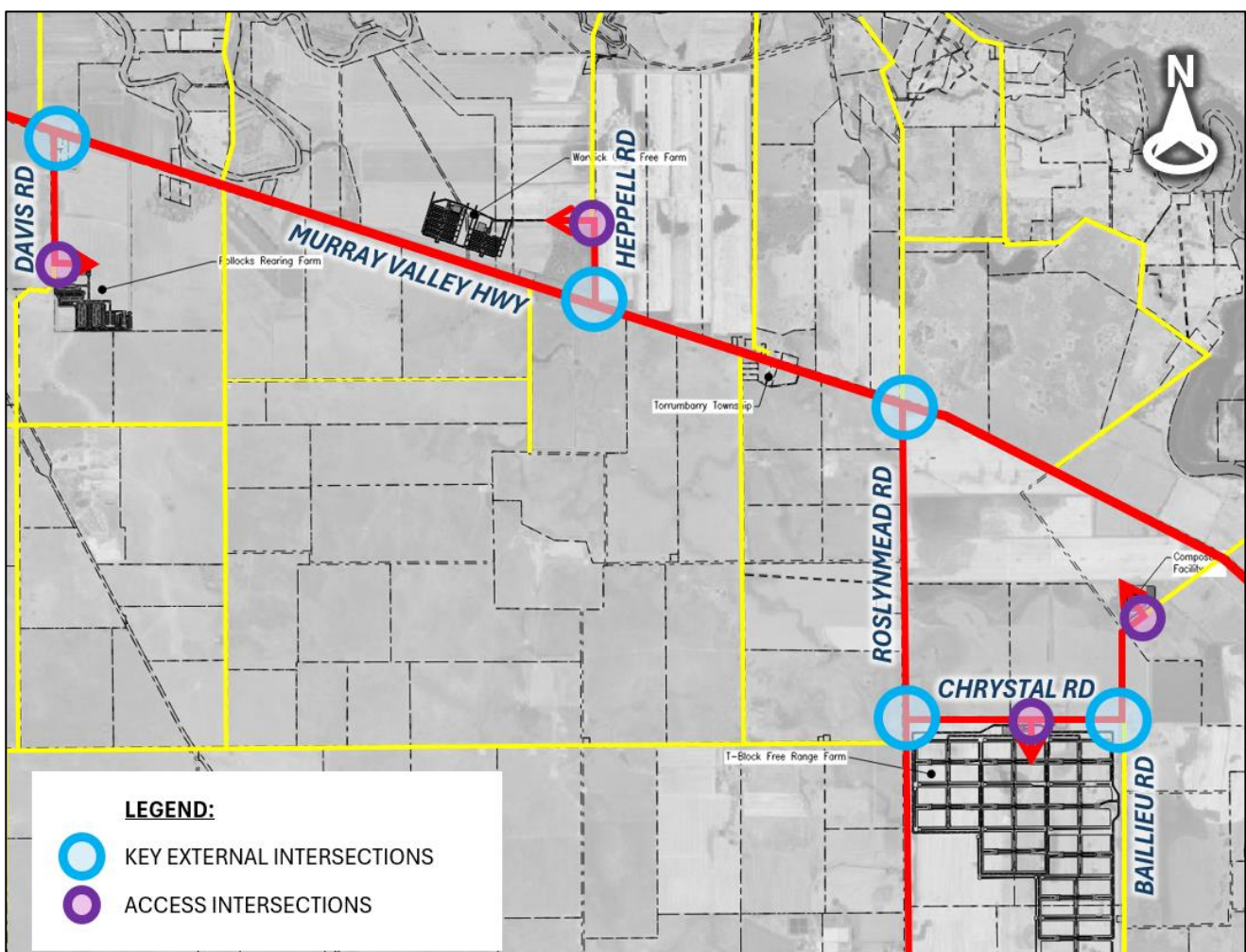

**Figure 4-8: Key intersections**

It is noted that there are other intersections in the vicinity of the site that may be utilised by the development traffic, however, due to the location and expected distribution of development traffic, the above intersections are the only intersections where the impact of the development is considered of significance (i.e. development traffic being more than five per cent of the background traffic).

#### 4.3.1 Murray Valley Highway / Roslynmead Road / Bail Road

The intersection of the Murray Valley Highway / Roslynmead Road / Bail Road consists of a priority controlled four leg intersection (refer to **Figure 4-9**), with 'Give-Way' signage and line-marking on the Roslynmead Road and Bail Road legs. Each leg of the intersection consists of one approach lane and one departure lane.

The intersection allows all turning movements and has shoulders that act as quasi basic left turn and basic right turn provisions. The shoulder line on the western approach on Murray Valley Highway is denoted by continuity (dashed) line marking which suggests that this approach may be for left turning provisions.

The Roslynmead Road leg has recently been upgraded to a widened seal.



Figure 4-9: Murray Valley Highway / Roslynmead Road / Bail Road intersection

#### 4.3.2 Murray Valley Highway / Heppell Road

The intersection of the Murray Valley Highway / Heppell Road consists of a priority controlled T intersection (refer to **Figure 4-10**), with 'Give-Way' signage on the Heppell Road leg. Each leg of the intersection consists of one approach lane and one departure lane. The Heppell Road leg is unsealed gravel formation.

The intersection allows all turning movements and does not have any dedicated turning lanes.



Figure 4-10: Murray Valley Highway / Heppell Road intersection

#### 4.3.3 Murray Valley Highway / Davis Road

The intersection of the Murray Valley Highway / Davis Road consists of a priority controlled T intersection (refer to **Figure 4-11**), with 'Give-Way' signage on the Davis Road leg. Each leg of the intersection consists of one approach lane and one departure lane.

The intersection allows all turning movements and has shoulder on the eastern approach that act as quasi basic left turn provisions.



Figure 4-11: Murray Valley Highway / Davis Road intersection

#### 4.3.4 Roslynmead Road / Chrystal Road

The intersection of Roslynmead Road / Chrystal Road consists of a priority controlled T intersection (refer to **Figure 4-12**), with no signage or line-marking on the Chrystal Road minor leg. Each leg of the intersection consists of one approach lane and one departure lane. The Chrystal Road leg is unsealed gravel formation.

The intersection allows all turning movements and does not have any dedicated turning lanes.

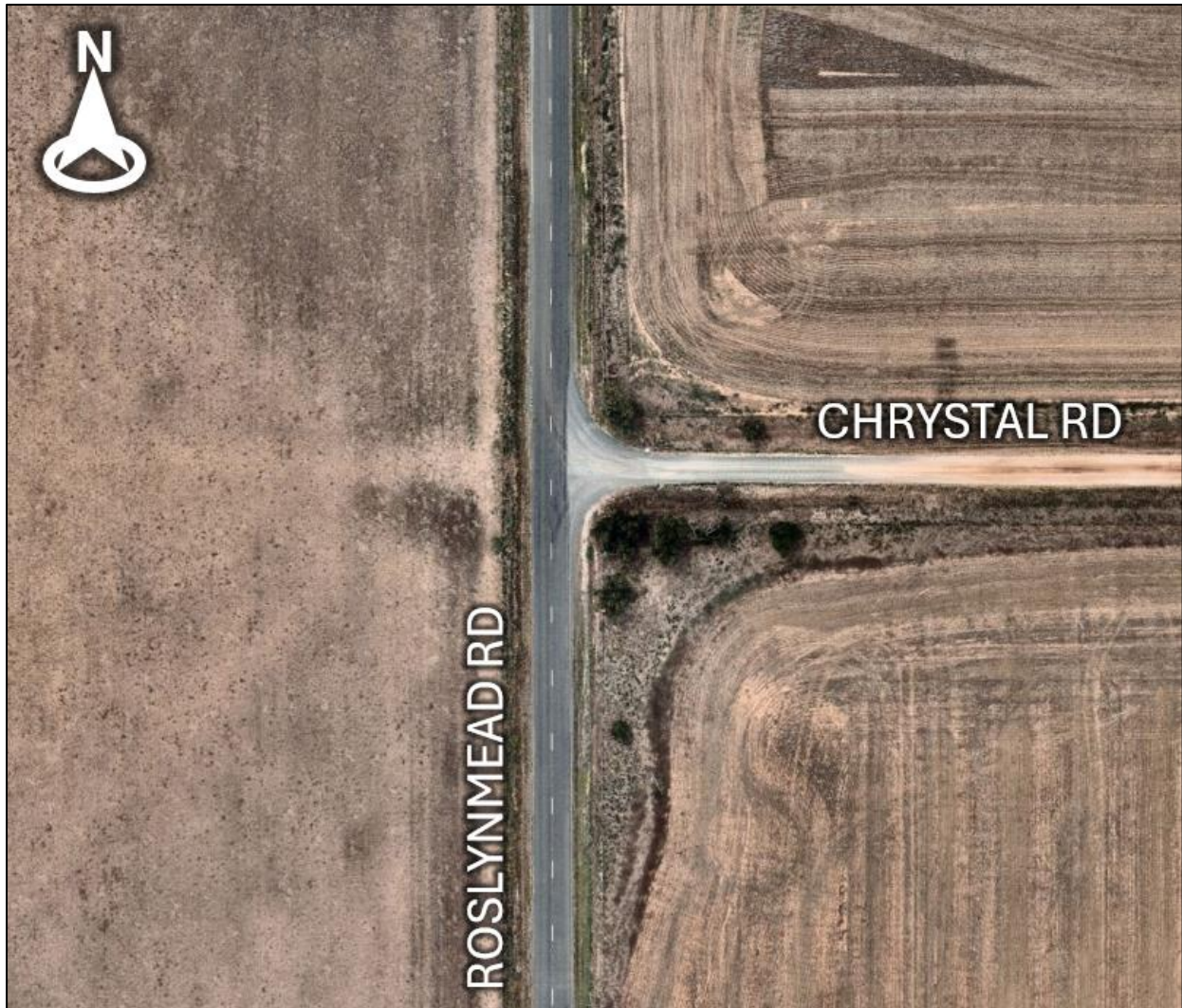

Figure 4-12: Roslynmead Road / Chrystal Road intersection

#### 4.3.5 Baillieu Road / Chrystal Road

The intersection of the Baillieu Road / Chrystal Road consists of a priority controlled T intersection (refer to **Figure 4-13**), with no signage or line-marking on the Chrystal Road minor leg. It is noted that there is a private driveway opposite the Chrystal Road minor leg. Each leg of the intersection consists of one approach lane and one departure lane. All legs of the intersection are unsealed gravel formation.

The intersection allows all turning movements and does not have any dedicated turning lanes.



Figure 4-13: Baillieu Road / Chrystal Road intersection

## 4.4 Crash data

### 4.4.1 Crash data for past 5 year period

Transport Victoria crash data was reviewed for the previous 5 years from 1 January 2019 until present. Data was obtained from *Transport Victoria (Victorian road crash data) ODP mapping*.

Findings indicate that there were four recorded crashes in the immediate vicinity of the site and associated key intersections.

The recorded crash locations are illustrated in **Figure 4-14**, with details of the recorded crashes summarised in **Table 4-1**.

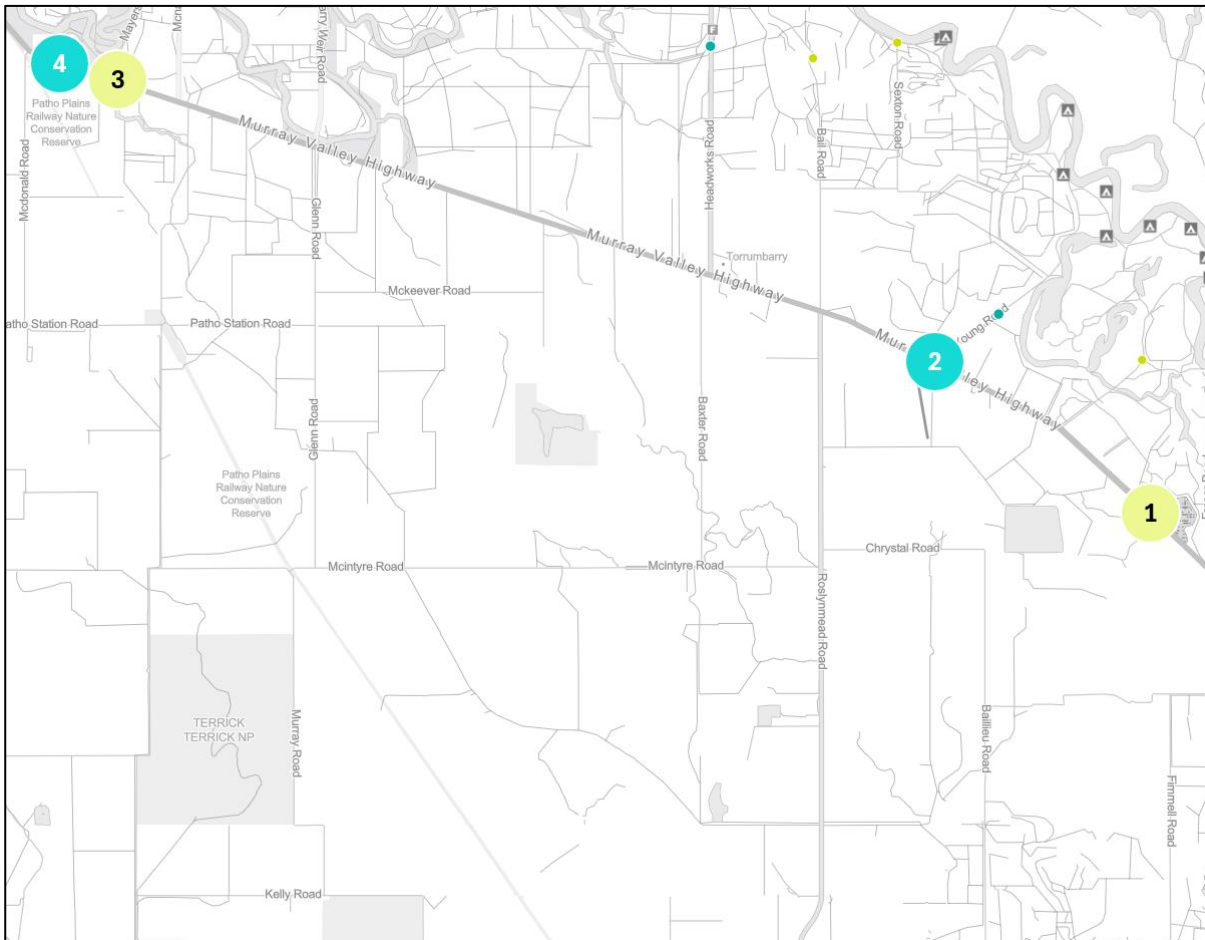

**Figure 4-14: Historical crash locations for past 5 year period (from *Transport Victoria (Victorian road crash data) ODP mapping*)**

**Table 4-1: Crash data for past 5 year period**

No.	Crash year	Severity	DCA code	DCA description	Light condition
1	2022	Other injury accident	173	Right off carriageway into object/parked vehicle	Daylight
2	2021	Serious injury accident	152	Pulling out (overtaking)	Daylight
3	2023	Other injury accident	111	Right far (intersections only)	Daylight
4	2021	Serious injury accident	171	Left off carriageway into object/parked vehicle	Daylight

The recorded crash data indicates that each crash is different in location and nature, and therefore no crash patterns could be determined from the review.

Further commentary regarding the suitability of the existing road network is detailed in **Section 8.4**.

#### 4.4.2 Crash data for past 15-year period

As part of the draft planning permit application review process, Transport for Victoria indicated that a 15-year period is preferred for crash data assessments.

In response, it is important to note that crash data is commonly examined for the previous 5 year period, per Austroads guidelines and considered standard practice. Extending the review period beyond this is deemed to be outdated due to the following reasons:

- 1) Road features and conditions may have changed significantly over time.
- 2) Mitigation for crashes in the preceding periods should have been appropriately addressed by the relevant road authority.

Nevertheless, in alignment with Transport for Victoria’s request, crash data has been reviewed for the previous 15 years from 1 January 2010 until present. This data, provided by Transport for Victoria in September 2025, is included in **Appendix I**.

The recorded crash locations are illustrated in **Figure 4-15**, with details of the recorded crashes summarised in **Table 4-2**

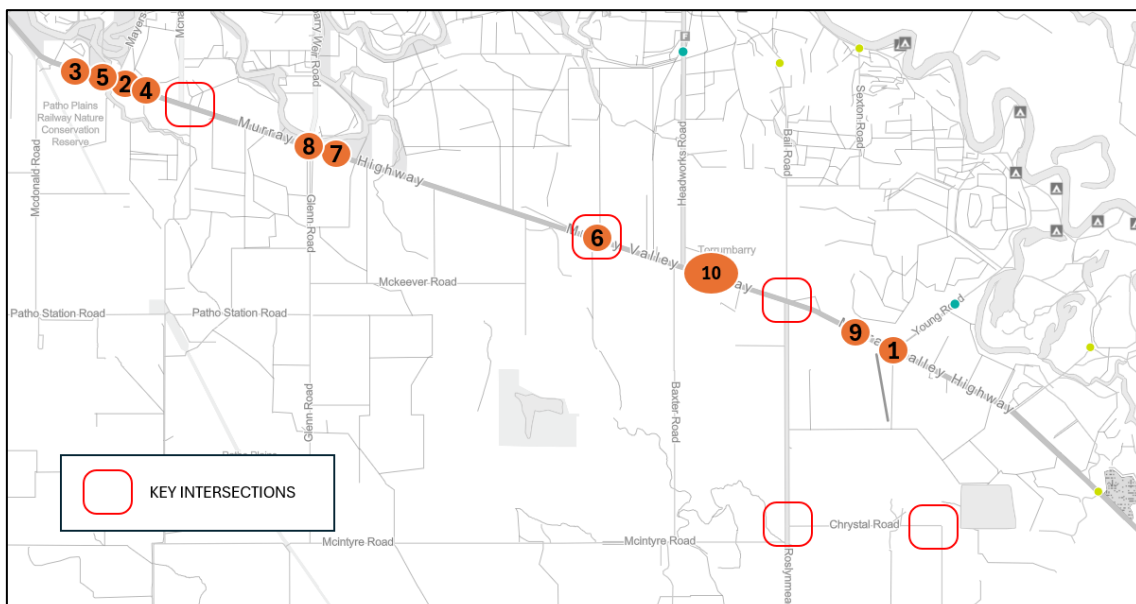

**Figure 4-15: Historical crash locations for past 15 year period**

**Table 4-2: Crash data for past 15 year period**

No.	Crash year	Severity	DCA code	DCA description	Light condition
1	2021	Serious injury accident	152	Pulling out (overtaking)	Daylight
2	2023	Other injury accident	111	Right far (intersections only)	Daylight
3	2021	Serious injury accident	171	Left off carriageway into object/parked vehicle	Daylight
4	2010	Serious injury accident	172	Off carriageway to right	Dusk
5	2012	Fatal accident	179	Other accident-off path on straight	Daylight
6	2013	Other injury accident	171	Left off carriageway into object/parked vehicle	Dark-not lighted
7	2016	Serious injury accident	129	Other opposing manoeuvres	Dark-lighted
8	2017	Serious injury accident	132	Right rear end	Daylight
9	2015	Other injury accident	171	Left off carriageway into object/parked vehicle	Daylight
10	2017	Serious injury accident	120	Head on (not overtaking)	Daylight

Findings indicate that there were 10 recorded crashes along Murray Valley highway between Patho School Road and Young Road. Of the 10 crashes:

- 5 were single vehicles crashes (lost control/off carriageway)
- 2 were midblock (head-on, pulling out from side of the highway)
- 3 were intersection crashes (all at different intersections/driveways not associated with our development including School Road, Torrumbarry Weir Road and a private driveway access).

No pattern of intersection crashes can be identified from this data. A pattern of run-off road incidents could be argued for the length of the corridor but these occurred through the area and were not concentrated to a specific location.

Furthermore, it should also be noted that a concentration of crashes occurred in the vicinity of Patho School Road (3 out of the 10 crashes). However, this intersection and bridge have since been upgraded within the crash reporting time period.

Therefore, from review of the historical crash data, no mitigation or upgrades are required.

Further commentary regarding the suitability of the existing road network is detailed in **Section 8.4**.

## 4.5 Existing traffic volumes

Traffic data was obtained from manual intersection traffic movement surveys, as well as via a first principles assessment, to identify the existing traffic volumes of the surrounding road network.

### 4.5.1 Survey data

Manual traffic survey data was undertaken by Austraffic at the following key intersections:

- Murray Valley Highway / McNaught Road
- Murray Valley Highway / Davis Road
- Murray Valley Highway / Roslynmead Road / Bail Road

A summary of the survey data peak periods are shown below in **Table 4-3**. The count surveys from Austraffic are provided in **Appendix C**.

**Table 4-3: Traffic survey data**

Intersection	Date	AM peak hour	PM peak hour
Murray Valley Highway / McNaught Road	Wednesday, 7 May 2025	8:45-9:45am	3:45-4:45pm
Murray Valley Highway / Davis Road	Wednesday, 7 May 2025	8:45-9:45am	3:45-4:45pm
Murray Valley Highway / Roslynmead Road / Bail Road	Wednesday, 7 May 2025	9:15-10:15am	3:30-4:30pm

The traffic count surveys indicate a background AM and PM network peak hour period of 9:00-10:00am and 3:45-4:45pm respectively.

### 4.5.2 First principles assessment – Heppell Road and Chrystal Road traffic volumes

Background traffic volumes for Heppell Road and Chrystal Road have been nominated based on a first principal assessment for rural residential land uses.

#### ***Heppell Road***

Heppell Road is a dry weather road with a limited catchment of approximately four residential dwellings. The estimated traffic generation of the existing Heppell Road catchment shown in **Table 4-4**, was determined using the following parameters (based from the *NSW RTA Guide to Traffic Generating Developments (2002)*):

- Traffic generation rate of 0.85 trips per dwelling in the AM and PM peak hour periods.
- In / out splits of 30 per cent / 70 per cent for the AM peak and 70 per cent / 30 per cent for the PM peak.

**Table 4-4: Estimated peak hour traffic generation (existing Heppell Road catchment)**

Total number of dwellings	Total peak hour trips	AM		PM	
		In	Out	In	Out
4	3	1	2	2	1

*Note: trips rounded to the nearest number*

In the absence of intersection turning volume data, the above traffic volumes and a directional distribution split of 80 per cent east and 20 per cent west via the Murray Valley Highway were adopted to determine turning movements at the Murray Valley Highway / Heppell Road intersection. The estimated external distributions assumed have been based on consideration of local surrounding attractors, and traffic survey data of nearby intersections.

Given the low peak hour volumes, the application of the in/out splits and distribution results in less than one vehicle trip for each movement. Therefore, for the assessment, one vehicle trip has been adopted on each movement at the Murray Valley Highway / Heppell Road intersection for the AM and PM peak hours.

#### **Chrystal Road**

Chrystal Road is a dry weather road with a limited catchment of one residential dwelling. There are no major origins or destinations along this section of road (only farmland), and it is not considered to be a major connecting road as there are other more direct routes in the network. Therefore, as per Heppell Road above, for the assessment, one vehicle trip has been adopted on each movement at the Roslynmead Road / Chrystal Road intersection for the AM and PM peak hours.

#### **4.5.3 Historical growth rate**

Historical growth of the network was approximated by the VicRoads daily traffic count data available for the Murray Valley Highway in the vicinity of the development sites. The historic five-year growth and ten-year growth both equate to approximately three per cent per annum.

Therefore, a compound growth rate of three per cent per annum has been adopted for the assessment for all key roads and intersections.

#### **4.5.4 Heavy vehicle percentages**

The following heavy vehicle percentages have been adopted for the background traffic volumes based from the 2025 manual traffic counts:

- Murray Valley Highway – 20% heavy vehicles
- Davis Road – 70% heavy vehicles
- Roslynmead Road – 25% heavy vehicles
- Other minor rural roads – 20% heavy vehicles

#### 4.5.5 Assessment scenarios

From the abovementioned operational data, and the above count data, it was identified that the external road network peak hours (AM and PM) do not coincide with the peak hours of the development traffic movements at the key intersections. For the purpose of the operational analysis and turn warrant assessment, the following assessment scenarios have been considered for the different peak hours throughout the weekday:

- Network Peak period → associated with the background traffic peak periods:
  - › AM – 9:00-10:00am
  - › PM – 3:45-4:45pm
- Development Peak 1 → associated with staff movements for Warwick’s Block and T-Block:
  - › AM – 5:00-6:00am
  - › PM – 2:00-3:00pm
- Development Peak 2 → associated with staff movements for Pollock’s Block and the Composting Facility:
  - › AM – 6:00-7:00am
  - › PM – 3:00-4:00pm

The assessment years for each of the above scenarios include:

- Development completion (ultimate for all stages) → 2042
- Ten year design horizon → 2052

From the above, the adopted background traffic volumes for each of the above scenarios are illustrated in **Appendix D**.

## 5. Planning considerations

From a review of online mapping, no planned state or local government road upgrades are proposed within the vicinity of the site.

It is understood that Davis Road may be upgraded in future to a sealed and widened cross section to accommodate heavy vehicle movements to and from the Veolia Patho Landfill site. It is understood that Council currently have plans for this road upgrade, however, no funding has been granted at the time of writing this report.

## 6. Development traffic volumes

From the operational details (refer to **Section 3**), the estimated peak hour 'development' traffic volumes and 'background with development' traffic volumes are illustrated in **Appendix E** for the Network Peak period, Development Peak 1 and Development Peak 2 scenarios, for each assessment year (2042 completion year and the 2052 design horizon). The development traffic volumes represent the total ultimate development of each site (all stages).

## 7. Development traffic impact on external road network

**Table 7-1** provides information relating to the typical maximum traffic volume combinations for uninterrupted traffic flow conditions. These combinations provide guidance for unsignalised intersections carrying light crossing and turning volumes. Where the volumes are less than that illustrated in **Table 7-1**, it is considered unnecessary to flare intersection approaches or carry out an intersection analysis.

**Table 7-1: Intersection capacity – uninterrupted flow conditions**

Major road type <sup>1</sup>	Major road flow (vph) <sup>2</sup>	Minor road flow (vph) <sup>3</sup>
Two-lane	400	250
	500	200
	650	100

1. Major road is the through road i.e. has priority
2. Major road design volumes include through and turning movements
3. Minor road design volumes include through and turning volumes

The anticipated ultimate 2052 ‘background with development’ traffic volumes detailed in **Appendix E** do not exceed the hourly volume combinations shown in **Table 7-1** for the key intersections. Therefore, intersection analysis is not deemed warranted for the key intersection locations. It is expected that these key intersections will operate under practical capacity with the proposed development volumes.

Although operational analysis is therefore not deemed warranted for the key intersections, analysis has nevertheless been undertaken in consideration of turning movement provision and associated potential saturation and delay of the Murray Valley Highway intersections to illustrate the operational impact.

### 7.1 Intersection operational assessment

#### 7.1.1 Assessment area

The assessment area includes the key intersections of Murray Valley Highway, as follows:

- Murray Valley Highway / Roslynmead Road / Bail Road
- Murray Valley Highway / Heppell Road
- Murray Valley Highway / Davis Road

### 7.1.2 Assessment scenarios

As stated in **Section 4.5.5**, for the purpose of this assessment the following scenarios have been assessed for the ultimate development (all stages) with “background with development” traffic volumes:

- 2052 AM Network Peak period
- 2052 PM Network Peak period
- 2052 AM Development Peak 1
- 2052 PM Development Peak 1
- 2052 AM Development Peak 2
- 2052 PM Development Peak 2

### 7.1.3 Intersection modelling parameters

The key Murray Valley Highway intersections were assessed using SIDRA 10.0 intersection analysis program. This program calculates the operational performance of intersections based on input parameters such as geometry and traffic volumes. Output values that have been recorded include the degree of saturation (DOS), queue lengths (in metres) and delay times (in seconds). The DOS is a commonly used value, which is principally a volume to capacity ratio.

The typical desired standards of service (DSS) values for DOS and intersection performance are summarised in **Table 7-2**. A DOS exceeding these values indicates that the intersection is exceeding its practical capacity and users of the intersection are likely to experience unsatisfactory queuing and delays.

**Table 7-2: Typical acceptable DOS for intersections**

Intersection type	Maximum DOS
Signalised intersection	90 – 95% (0.90 – 0.95)
Roundabout	85% (0.85)
Unsignalised intersections	80% (0.80)

These values are also recommended by Austroads Guide to Traffic Management – Part 12.

## 7.2 Intersection operational assessment results

A summary of the traffic assessment results is shown below in **Table 7-3**. SIDRA intersection layouts and detailed results are included in **Appendix F**.

**Table 7-3: SIDRA analysis results (2052 Background with Development traffic)**

Intersection	Peak	Demand flow (vph)	SIDRA output			
			Degree of saturation (DOS)	Max. avg. delay (s)*	LoS	95%ile queue (m)*
<b>Murray Valley Highway / Roslynmead Road / Bail Road</b>	Network AM	621	0.21	17	C	3
	Network PM	636	0.18	12	B	2
	Dev Peak 1 AM	199	0.07	10	B	1
	Dev Peak 1 PM	678	0.22	19	C	3
	Dev Peak 2 AM	354	0.10	10	B	2
	Dev Peak 2 PM	638	0.19	15	C	2
<b>Murray Valley Highway / Heppell Road</b>	Network AM	615	0.20	13	B	1
	Network PM	621	0.19	12	B	1
	Dev Peak 1 AM	164	0.05	9	A	2
	Dev Peak 1 PM	638	0.19	14	B	2
	Dev Peak 2 AM	340	0.12	11	B	1
	Dev Peak 2 PM	627	0.21	12	B	1
<b>Murray Valley Highway / Davis Road</b>	Network AM	568	0.18	17	C	2
	Network PM	593	0.17	14	B	1
	Dev Peak 1 AM	123	0.04	10	B	<1
	Dev Peak 1 PM	557	0.16	16	C	2
	Dev Peak 2 AM	286	0.10	12	B	1
	Dev Peak 2 PM	572	0.17	12	B	2

\* rounded to the nearest whole number

The SIDRA models shows that all the key Murray Valley Highway intersections operate within performance standards for the 2052 ultimate scenario, for the three key peaks. Table 7-3 indicates that the intersections operate well below the DSS with minimal saturation, delays and queues. In addition to this, no individual movements exceed the 42-second delay threshold for unacceptable delay related to priority-controlled intersections.

It is recognised that the other key intersections of Roslynmead Road / Chrystal Road, and Baillieu Road / Chrystal Road, as well as all the proposed development accesses, will also operate well within the DSS given the lower vehicular demands compared to the Murray Valley Highway intersections.

From the above, the development impact on the key external intersections do not cause any adverse operational issues. The intersections operate well within performance thresholds and therefore, no mitigation of operational impacts or upgrades are required for the key external intersections.

### 7.3 Mid-block assessment (link level of service)

Level of service (LoS) values for midblock locations on urban roads with interrupted flow conditions are described in **Table 7-4**.

Peak hour traffic flow ranges are based on broad assumptions and could potentially change depending on the width of traffic lanes, adjacent intersection arrangements and other factors. Typically, mid-block LoS E and LoS F would require upgrades with additional through lanes, or duplication, to increase capacity.

**Table 7-4: Midblock level of service description**

Level of service		Peak hour traffic flow (veh per hour per lane)	
		From	To
A	Free flow – drivers are virtually unaffected by other drivers in the traffic stream	0	200
B	Stable flow – drivers have reasonable freedom to manoeuvre and select their desired speed	200	380
C	Stable flow – drivers are restricted to some extent in their freedom to manoeuvre and select their desired speed	380	600
D	Approaching unstable flow – drivers are severely restricted in their freedom to manoeuvre and select their desired speed	600	900
E	Unstable flow – traffic volumes at or close to capacity, drivers have virtually no freedom to manoeuvre or select their desired speed	900	1,400
F	Forced flow – traffic volumes over capacity with flow breakdown, queueing and delays	Greater than 1,400	

Source: *Guide to Traffic Generating Developments (NSW RMS, 2002)*

The mid-block level of service for Murray Valley Highway with the future ultimate development demands (i.e. 2052 Background with Development volumes) is LoS B with a maximum peak hour traffic flow of approximately 360vph per lane in each direction. All other key roads are expected to operate with a peak hour traffic flow of less than 70vph per direction which results in a mid-block LoS A.

Therefore, the key roads operate within the mid-block requirements for the existing lane capacities. No upgrades are required on the surrounding external road network with regards to operational capacity.

## 8. Safety considerations

### 8.1 Crash data

As per **Section 4.4**, the recorded crash data indicates that each crash is different in location and nature, and therefore no crash patterns could be determined from the review. It is recommended that ongoing monitoring of crashes in the area be conducted by the relevant road authority to determine crash patterns and relevant mitigation measures in the future.

### 8.2 Turn warrant assessment

Turn warrants are used to identify the need to provide separate turning provisions from a functionality and safety perspective. The warrants are essentially the relationship between the turning volumes versus the major road traffic volumes.

In accordance with Austroads, turn warrants are based on the construction of new roads (i.e. greenfield sites) and is also used as a reference for intervention levels for updating existing intersection turn treatments. Turn warrant assessment is usually undertaken at these intersections to determine if protected turning lanes (i.e. channelisation) are required from a safety perspective.

**Table 8-1** summarises the warrant treatments required at the key intersections with respect to traffic volumes provided in **Appendix D** and **Appendix E**. Detailed turn warrant graphs are provided at **Appendix G**.

**Table 8-1: Turn warrant summary results (2052)**

Intersection	Peak	Background		Background with Development	
		Left turn treatment triggered*	Right turn treatment triggered*	Left turn treatment triggered*	Right turn treatment triggered*
Murray Valley Highway / Roslynmead Road	Network AM	BAL	CHR	BAL	CHR
	Network PM	BAL	CHR(S)	BAL	CHR
	Dev Peak 1 AM	BAL	BAR	BAL	BAR
	Dev Peak 1 PM	BAL	CHR	BAL	CHR
	Dev Peak 2 AM	BAL	CHR(S)	BAL	CHR(S)
	Dev Peak 2 PM	BAL	CHR	BAL	CHR
Murray Valley Highway / Heppell Road	Network AM	BAL	BAR	BAL	BAR
	Network PM	BAL	BAR	BAL	BAR
	Dev Peak 1 AM	BAL	BAR	BAL	BAR
	Dev Peak 1 PM	BAL	BAR	BAL	BAR
	Dev Peak 2 AM	BAL	BAR	BAL	BAR
	Dev Peak 2 PM	BAL	BAR	BAL	BAR

<b>Murray Valley Highway / Davis Road</b>	Network AM	BAL	BAR	BAL	BAR
	Network PM	BAL	BAR	BAL	BAR
	Dev Peak 1 AM	BAL	BAR	BAL	BAR
	Dev Peak 1 PM	BAL	BAR	BAL	BAR
	Dev Peak 2 AM	BAL	BAR	BAL	BAR
	Dev Peak 2 PM	BAL	BAR	BAL	BAR
<b>Roslynmead Road / Chrystal Road</b>	Network AM	BAL	BAR	BAL	BAR
	Network PM	BAL	BAR	BAL	BAR
	Dev Peak 1 AM	BAL	BAR	BAL	BAR
	Dev Peak 1 PM	BAL	BAR	BAL	BAR
	Dev Peak 2 AM	BAL	BAR	BAL	BAR
	Dev Peak 2 PM	BAL	BAR	BAL	BAR
<b>Pollock's Block Access (Davis Road)</b>	Network AM	-	-	BAL	BAR
	Network PM	-	-	BAL	BAR
	Dev Peak 1 AM	-	-	BAL	BAR
	Dev Peak 1 PM	-	-	BAL	BAR
	Dev Peak 2 AM	-	-	BAL	BAR
	Dev Peak 2 PM	-	-	BAL	BAR
<b>T-Block Access (Chrystal Road)</b>	Network AM	-	-	BAL	BAR
	Network PM	-	-	BAL	BAR
	Dev Peak 1 AM	-	-	BAL	BAR
	Dev Peak 1 PM	-	-	BAL	BAR
	Dev Peak 2 AM	-	-	BAL	BAR
	Dev Peak 2 PM	-	-	BAL	BAR

\* BAR – Basic right turn treatment, CHR(S) – Channelised right turn (short) treatment, CHR - Channelised right turn (full) treatment

\* BAL – Basic left turn treatment

From the assessment, the turning movements at the key intersections fall within basic turn treatment thresholds (i.e. BAL and BAR), with the exception of Murray Valley Highway / Roslynmead Road which triggers a CHR turn treatment in the background scenario, regardless of the development. It is noted that this is similar for the 2042 completion year where the background volumes trigger CHR(S) turn treatment and the addition of the development traffic does not trigger any treatment greater than this.

Therefore, no mitigation measures are triggered by the development at the external key intersections as the development does not cause the requirement for additional turning treatments above what is already required by the background traffic volumes.

As per the turn warrant outcomes, all new accesses and intersections should be constructed with consideration of basic turning treatments (BAL and BAR).

### 8.3 Safe intersection sight distance assessment

#### 8.3.1 Safe intersection sight distance

Safe intersection sight distance has been reviewed for the existing key intersections. The review was completed to confirm applicable sight distance requirements in accordance with Austroads guidelines. The sight distance requirements at the intersections are derived from the formulae (Equation 2) specified in *Guide to Road Design - Part 4a*, as follows:

$$SISD = \frac{D_T \times V}{3.6} + \frac{V^2}{254 \times (d + 0.01 \times a)}$$

**Table 8-2** summarises the variables used for this calculation. It is noted that all key roads are either signed as 100km/h (posted speed limits) or are unsigned, and therefore a rural unposted default speed limit of 100km/h applies.

**Table 8-2: Variables adopted for sight distance assessment**

Variable symbol	Description	Value adopted for assessment		Unit of Measure
		Truck	Car	
<b>All key intersections</b>				
<b>DT</b>	Decision time (s) = observation time (3 s) + reaction time (s)	5.5	5.5	seconds
<b>V</b>	Operating (85 <sup>th</sup> percentile) speed	110	110	km/h
<b>d</b>	Coefficient of deceleration for cars / trucks ( <i>Guide to Road Design – Part 3: Geometric Design (Austroads 2009a)</i> )	0.29	0.36	
<b>a</b>	Longitudinal grade in % (in direction of travel: positive for uphill grade, negative for downhill grade)	0	0	%
<b>R<sub>T</sub></b>	Perception/reaction time ( <i>Guide to Road Design – Part 3: Geometric Design (Austroads 2009a)</i> )	2.5	2.5	seconds

The outcomes of this sight distance review are summarised in **Table 8-3**. The available sight distance is based on a desktop review of the intersections using Google Street View imagery.

**Table 8-3: SISD review summary**

Intersection	Approach leg	Vehicle type	Travel Direction	Available SISD	Required SISD	Compliance
<b>Murray Valley Highway / Roslynmead Road / Bail Road</b>	Murray Valley Highway	Truck	Westbound	>400m	332m	Compliant
			Eastbound	>400m	332m	Compliant
		Car	Westbound	>400m	300m	Compliant
			Eastbound	>400m	300m	Compliant
<b>Murray Valley Highway / Hepell Road</b>	Murray Valley Highway	Truck	Westbound	>400m	332m	Compliant
			Eastbound	>400m	332m	Compliant
		Car	Westbound	>400m	300m	Compliant
			Eastbound	>400m	300m	Compliant
<b>Murray Valley Highway / Davis Road</b>	Murray Valley Highway	Truck	Westbound	>400m	332m	Compliant
			Eastbound	>400m	332m	Compliant
		Car	Westbound	>400m	300m	Compliant
			Eastbound	>400m	300m	Compliant
<b>Roslynmead Road / Chrystal Road</b>	Roslynmead Road	Truck	Northbound	>400m	332m	Compliant
			Southbound	>400m	332m	Compliant
		Car	Northbound	>400m	300m	Compliant
			Southbound	>400m	300m	Compliant
<b>Baillieu Road / Chrystal Road</b>	Baillieu Road	Truck	Northbound	>400m*	332m	Compliant
			Southbound	>400m*	332m	Compliant
		Car	Northbound	>400m*	300m	Compliant
			Southbound	>400m*	300m	Compliant

\* estimated sight distance based from land survey given the flat terrain, minimal roadside vegetation and relatively flat grades of the roads.

The review indicates that the sight distance available at the key external intersections is satisfactory and meets the minimum SISD requirements for all approaches.

Given the relatively flat terrain and surrounding topography of the area, it is expected that the sight distance at each access location would meet relevant sight distance requirements. The sight distance of these accesses can be confirmed and appropriately designed during future detailed design phase of the development for each site.

### 8.4 Suitability of surrounding road network

An assessment has been undertaken to investigate and identify any possible safety concerns along the proposed key roads and traffic routes providing access to the proposed development sites in order to determine the suitability of the surrounding road network. Details of the suitability of the surrounding road network are provided in the sections below.

#### **8.4.1 Murray Valley Highway**

The Murray Valley Highway has suitable road geometry and sufficient sight lines available along the length of the road corridor, in the vicinity of the subject sites. The width of the pavement carriageway is approximately 9-10m, with 3.5m wide travel lanes and approximately 1.5m wide sealed shoulders on both sides of the road. From a desktop review, the existing cross section, pavement and road environment along the Murray Valley Highway is deemed suitable for development traffic.

Therefore, no mitigation measures or upgrades are deemed to be required by the development along the subject length of the Murray Valley Highway.

#### **8.4.2 Roslynmead Road**

Roslynmead Road pavement appears to be in good condition for a rural collector road. The road has suitable road geometry and sufficient sight lines available along the length of the road corridor, in the vicinity of the subject sites .

The width of the sealed pavement is approximately 6.5m, comprising two 3.3m wide lanes. There are no sealed road shoulders and as a result, minor edgewear is evident at intermittent locations along the corridor. From a desktop review, the existing cross section, pavement and road environment along Roslynmead Road is deemed suitable for development traffic.

It is recommended that the condition of Roslynmead Road be monitored. At this time, no mitigation measures or upgrades are deemed to be required by the development along the subject length of Roslynmead Road.

#### **8.4.3 Heppell Road**

Heppell Road is currently signed as a 'Dry Weather Road Only' and comprises an unsealed gravel/dirt carriageway. The terrain is flat, with sufficient sight lines available along the entire length of the road between the Murray Valley Highway and the proposed site access to Warwick's Block Cage Free Layer Farm. The unsealed pavement at the intersection with the Murray Valley Highway has deep wheel rutting and ponding which is not suitable for safe traffic movement.

As the Warwick's Block Cage Free Layer Farm intends to operate year round, with an average daily demand of over 150 vehicles per day, it is recommended the developer upgrades Heppell Road to a rural access road, including a 6.2m wide seal with 1.5m shoulders, suitable for traffic in all weather conditions (refer **Figure 8-1**). This upgrade is to be undertaken between the Murray Valley Highway and the proposed site access to Warwick's Block Cage Free Layer Farm. This upgrade is inline with the Campaspe Shire Council requirements of the Local Government Infrastructure Design Manual (Version 5.5 June 2025) - Table 6: *Rural Road Characteristics* and Standard Drawing 610: *Typical Road Profiles Low Density Rural Access*.

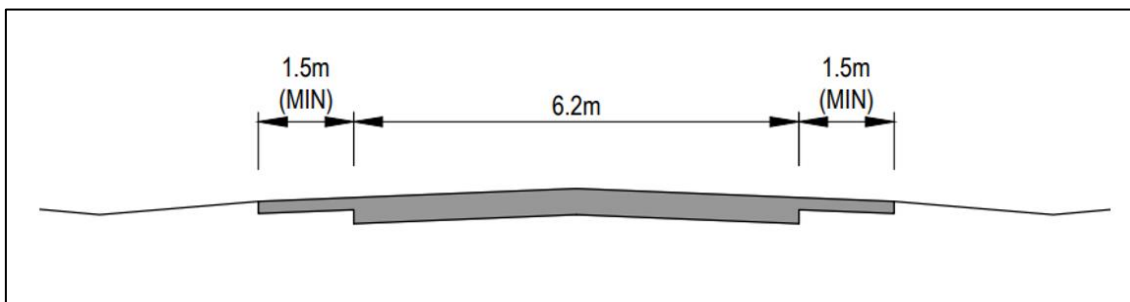

**Figure 8-1: Heppell Road – Proposed cross section**

#### **8.4.4 Davis Road**

The existing form of Davis Road comprises a sealed carriageway for approximately 300 m from the Murray Valley Highway with a width varying between approximately 4-6m, and gravel shoulders varying between 0.5-1.5m wide. Past this location, Davis Road is an unsealed gravel road, approximately 7m wide.

The existing 300m sealed portion reduces the amount of gravel migration from Davis Road to the Murray Valley Highway, however it is evident that some dust/gravel can migrate on the Highway. Therefore, it is recommended that this be monitored as the development operates.

The existing form of the gravel portion of Davis Road appears to be in good condition, with suitable road geometry and sufficient sight lines available along the entire length of the road between the Murray Valley Highway and the proposed site access for Pollock’s Block Rearing Farm.

Given that this road is used by heavy vehicles accessing the Veolia Patho Landfill site, and that the background volumes at the 2042 design year will be greater than 150 vehicles per day (vpd), it is recommended that Council upgrade Davis Road to a rural access road (with 6.2m wide seal with 1.5m shoulders), inline with the Campaspe Shire Council requirements of the Local Government Infrastructure Design Manual (Version 5.5 June 2025) - Table 6: *Rural Road Characteristics* and Standard Drawing 610: *Typical Road Profiles Low Density Rural Access*. This recommended upgrade is deemed required regardless of the proposed development.

Therefore, no mitigation measures or upgrades are deemed to be required by the development along the subject length of Davis Road.

#### **8.4.5 Chrystal Road**

The existing form of Chrystal Road is an unsealed gravel/dirt carriageway varying between approximately 4-6m wide. The terrain is flat, with sufficient sight lines available along the entire length of the road between Roslynmead Road and Baillieu Road.

Chrystal Road is the primary access road to the T-Block Free Range Layer Farm and the ‘Organic Nutrients’ Composting Facility and similar to Heppell Road, it is recommended that Chrystal Road is upgraded to local access road standards.

Given that the western section of Chrystal Road, between Roslynmead Road and the T-Block Free Range Layer Farm access, will have approximately 180vpd at the ultimate 2052 background with development scenario, it is recommended that this section of road be upgraded to a 6.2m wide seal with 1.5m shoulders, suitable for traffic in all weather conditions (refer **Figure 8-2**).

This upgrade is inline with the Campaspe Shire Council requirements of the Local Government Infrastructure Design Manual (Version 5.5 June 2025) - Table 6: *Rural Road Characteristics* and Standard Drawing 610: *Typical Road Profiles Low Density Rural Access*.

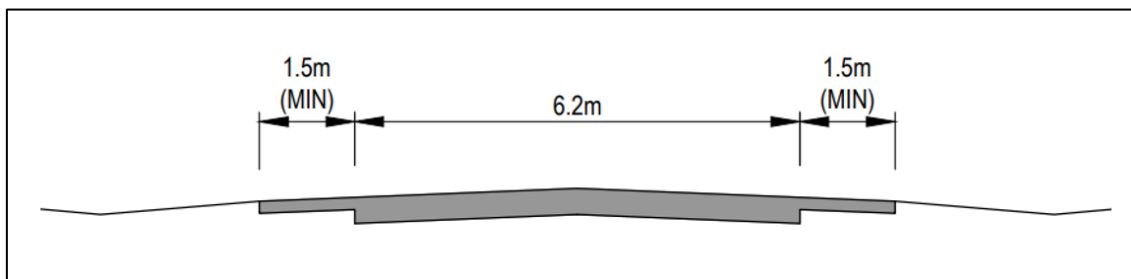

**Figure 8-2: Chrystal Road – Proposed cross section (western section)**

The eastern section of Chrystal Road, between the T-Block Free Range Layer Farm access and Baillieu Road is expected to have minimal traffic demands less than 100vpd at the ultimate 2052 background with development scenario. This section of road is recommended to be upgraded to a 4.0m wide single lane sealed pavement and 1.5m gravel shoulders, suitable for traffic in all weather conditions (refer **Figure 8-3**). This upgrade is inline with the Campaspe Shire Council requirements of the Local Government Infrastructure Design Manual (Version 5.5 June 2025) - Table 6: *Rural Road Characteristics*.

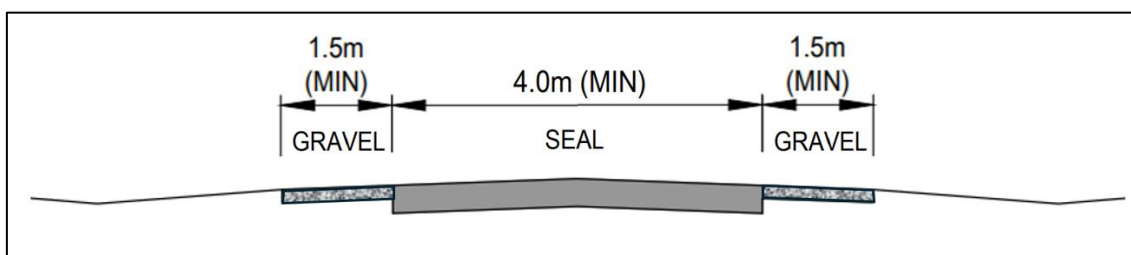
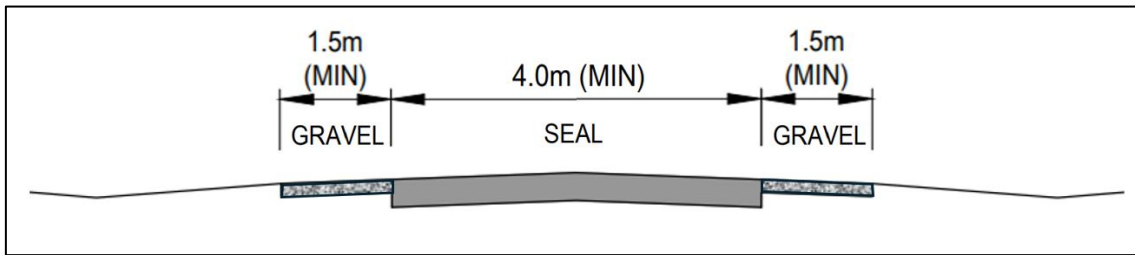

**Figure 8-3: Chrystal Road – Proposed cross section (eastern section)**

#### 8.4.6 Baillieu Road

The existing form of Baillieu Road is an unsealed gravel/dirt carriageway varying between approximately 4-6m wide. The terrain is flat, with sufficient sight lines available along the entire length of the road between the Chrystal Road and the site access to the 'Organic Nutrients' Composting Facility.

All manure collections from the associated farms are expected to travel to the 'Organic Nutrients' Composting Facility via Baillieu Road resulting in relatively low traffic volumes of less than 100vpd along Baillieu Road (i.e. similar to Chrystal Road (eastern section)). Therefore, it is recommended that Baillieu Road is upgraded to rural access road standards, including a 4.0m wide single lane sealed pavement and 1.5m gravel shoulders, suitable for traffic in all weather conditions (refer **Figure 8-4**). This upgrade is proposed for the section of Baillieu Road between Chrystal Road and the 'Organic Nutrients' Composting Facility access. This upgrade is inline with the Campaspe Shire Council requirements of the Local Government Infrastructure Design Manual (Version 5.5 June 2025) - Table 6: *Rural Road Characteristics*.



**Figure 8-4: Baillieu Road – Proposed cross section**

It is noted that there is a 120 degree curve in Baillieu Road located approximately 850m north of Chrystal Road. It is recommended that the pavement at this location be widened from the 4m carriageway width to accommodate two vehicles passing with applicable curve widening. This has been assessed with the provision of swept paths of two articulated vehicles (19m semi-trailers) passing each other at the curve location and is shown in **Figure 8-5** below.



**Figure 8-5: 19m AV turn path – Baillieu Road curve widening**

### 8.5 Suitability of surrounding intersections (swept path assessment)

A swept path assessment was undertaken for the largest design vehicle (19m semi-trailer) that will be utilising the key external intersections. The assessment was undertaken on the upgraded form of the intersections with the implementation of the turn warrant requirements (refer to **Section 8.2**) and the formation widths as described in the previous section (**Section 8.4**). The intersections have been checked and designed to adequately cater for two design vehicles (19m semi-trailers) to turn simultaneously without impact each other. The design vehicle dimensions are illustrated in **Figure 8-6** and the assessment includes 500mm buffer offsets from the truck body. The positioning of the Give Way holding line has also been considered as well as existing constraints. The intersection concept sketch drawings and associated swept path drawings are provided in **Appendix H**.

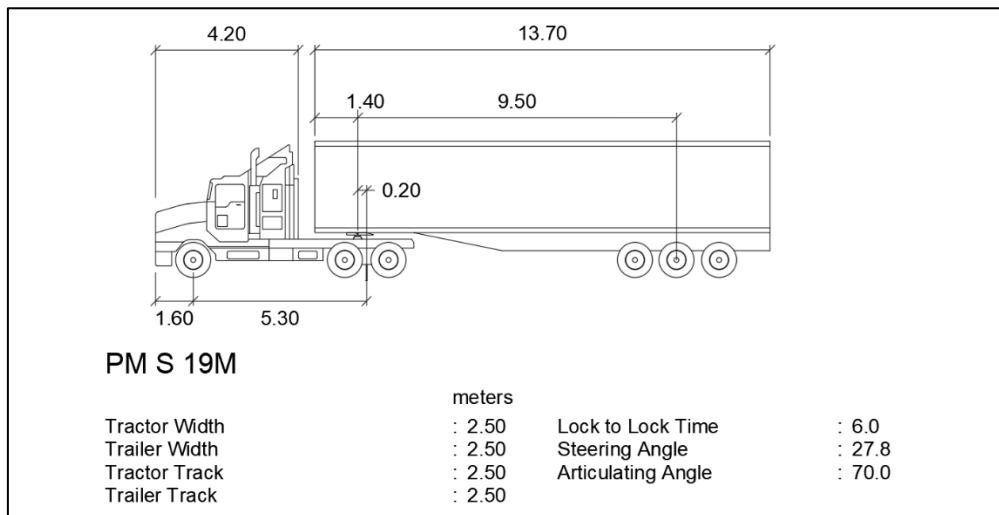

**Figure 8-6: 19m AV design vehicle profile – 2023 Austroads Standards**

It should be noted that the formation and geometry of each proposed access will be designed with respect to the applicable design vehicles in future detailed design stages and are not provided as part of the swept path assessment.

#### 8.5.1 Murray Valley Highway / Davis Road

The Murray Valley Highway / Davis Road intersection has been sketched with the turn warrant provisions of a BAL and BAR. As described in **Section 8.4.4**, the Davis Road carriageway is narrow and will need to be upgraded to a sealed 6.2m carriageway with 1.5m shoulders. The narrow carriageway, and associated small radius turnout at the Murray Valley Highway, has led to vehicles tracking over the verge to turn left in and right out of Davis Road. This is evident in **Figure 8-7** below.



**Figure 8-7: Evidence of vehicles tracking over verge at Davis Road turnout**

Therefore, the concept sketch layout for the intersection provided at **Appendix H** provides larger radius turnouts that have been widened to accommodate the design vehicles. The radius matches in with the current observations of vehicle trajectories at the intersection. Furthermore, it is also recognised that the existing culvert may need to be extended to provide for these larger turnouts and widening of Davis Road carriageway.

The recommended intersection geometry and swept paths for the Murray Valley Highway / Davis Road intersection are shown in **Figure 8-8**, **Figure 8-9** and **Figure 8-10**.



**Figure 8-8: Murray Valley Highway / Davis Road intersection upgrade concept sketch**



**Figure 8-9: Murray Valley Highway / Davis Road – 19m AV turn path – Right In / Left Out**

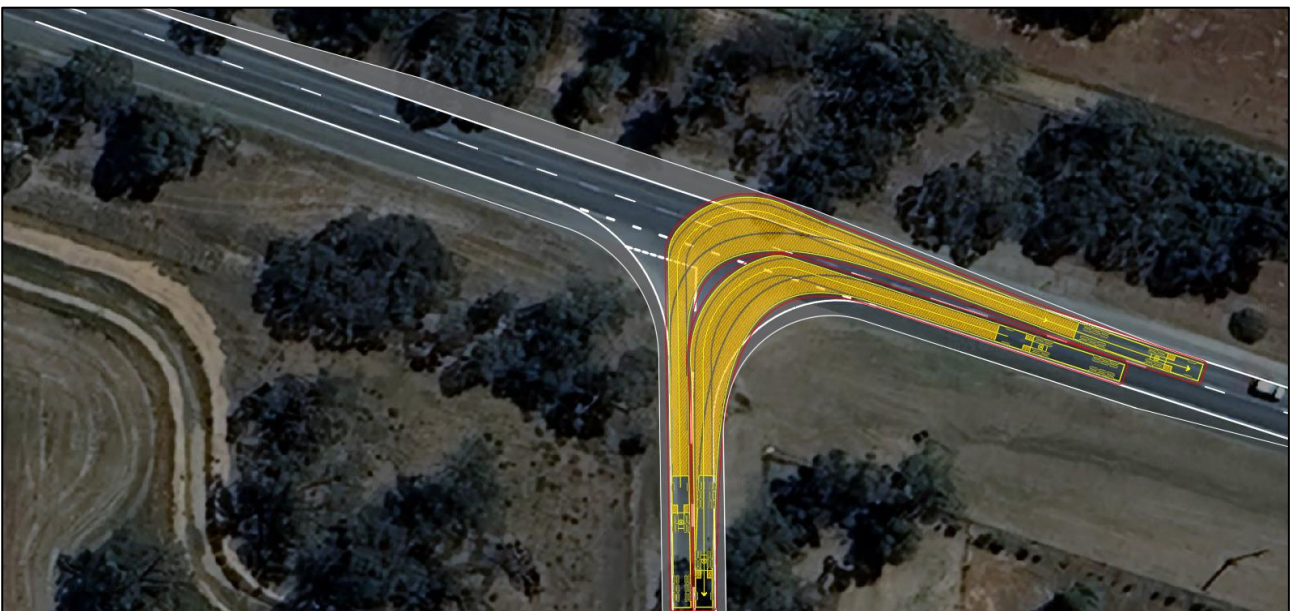

**Figure 8-10: Murray Valley Highway / Davis Road – 19m AV turn path – Left In / Right Out**

From the above figures, the recommended design geometry of the Murray Valley Highway / Davis Road intersection can adequately cater for the design vehicle movements.

### 8.5.2 Murray Valley Highway / Heppell Road

The Murray Valley Highway / Heppell Road intersection has been sketched with the turn warrant provisions of a BAL and BAR. As described in **Section 8.4.3**, the Heppell Road carriageway will be upgraded to a 6.2m sealed carriageway with 1.5m shoulders.

The proposed intersection geometry and swept paths for the Murray Valley Highway / Heppell Road intersection are shown in **Figure 8-11**, **Figure 8-12** and **Figure 8-13**.



**Figure 8-11: Murray Valley Highway / Heppell Road intersection upgrade concept sketch**



**Figure 8-12: Murray Valley Highway / Heppell Road – 19m AV turn path – Right In / Left Out**



**Figure 8-13: Murray Valley Highway / Heppell Road – 19m AV turn path – Left In / Right Out**

From the above figures, the proposed design geometry of the Murray Valley Highway / Heppell Road intersection can adequately cater for the design vehicle movements.

### **8.5.3 Murray Valley Highway / Roslynmead Road / Bail Road**

The Murray Valley Highway / Roslynmead Road / Bail Road intersection has been sketched with the turn warrant assessment outcomes of a full CHR and BAL for the Roslynmead Road leg. The Bail Road leg consists of a short CHR(S) and BAL turning provisions to compliment the design.

The concept sketch layout for the intersection provided at **Appendix H** provides larger radius turnouts for the Roslynmead leg to accommodate the design vehicles. No swept path assessment or upgrades have been provided for the Bail Road leg as no information regarding the traffic type or traffic demands is available, this leg is not utilised by the proposed development and the existing formation has been retained. It is recommended that Council consider the geometry of the northern Bail Road leg as part of the intersection design process.

The recommended intersection geometry and swept paths for the Murray Valley Highway / Roslynmead Road / Bail Road intersection are shown in **Figure 8-14**, **Figure 8-15** and **Figure 8-16**.



**Figure 8-14: Murray Valley Highway / Roslynmead Road intersection upgrade concept sketch**



**Figure 8-15: Murray Valley Highway / Roslynmead Road – 19m AV turn path – Right In / Left Out**



**Figure 8-16: Murray Valley Highway / Roslynmead Road – 19m AV turn path – Left In / Right Out**

From the above figures, the proposed design geometry of the Murray Valley Highway / Roslynmead Road intersection can adequately cater for the design vehicle movements.

#### 8.5.4 Roslynmead Road / Chrystal Road

The Roslynmead Road / Chrystal Road intersection has been sketched with the turn warrant provisions of a BAL and BAR. As described in **Section 8.4.5**, the western portion of the Chrystal Road carriageway will be upgraded to a 6.2m sealed carriageway with 1.5m shoulders.

The proposed intersection geometry and swept paths for the Roslynmead Road / Chrystal Road intersection are shown in **Figure 8-17**, **Figure 8-18** and **Figure 8-19**.



**Figure 8-17: Roslynmead Road / Chrystal Road intersection upgrade concept sketch**

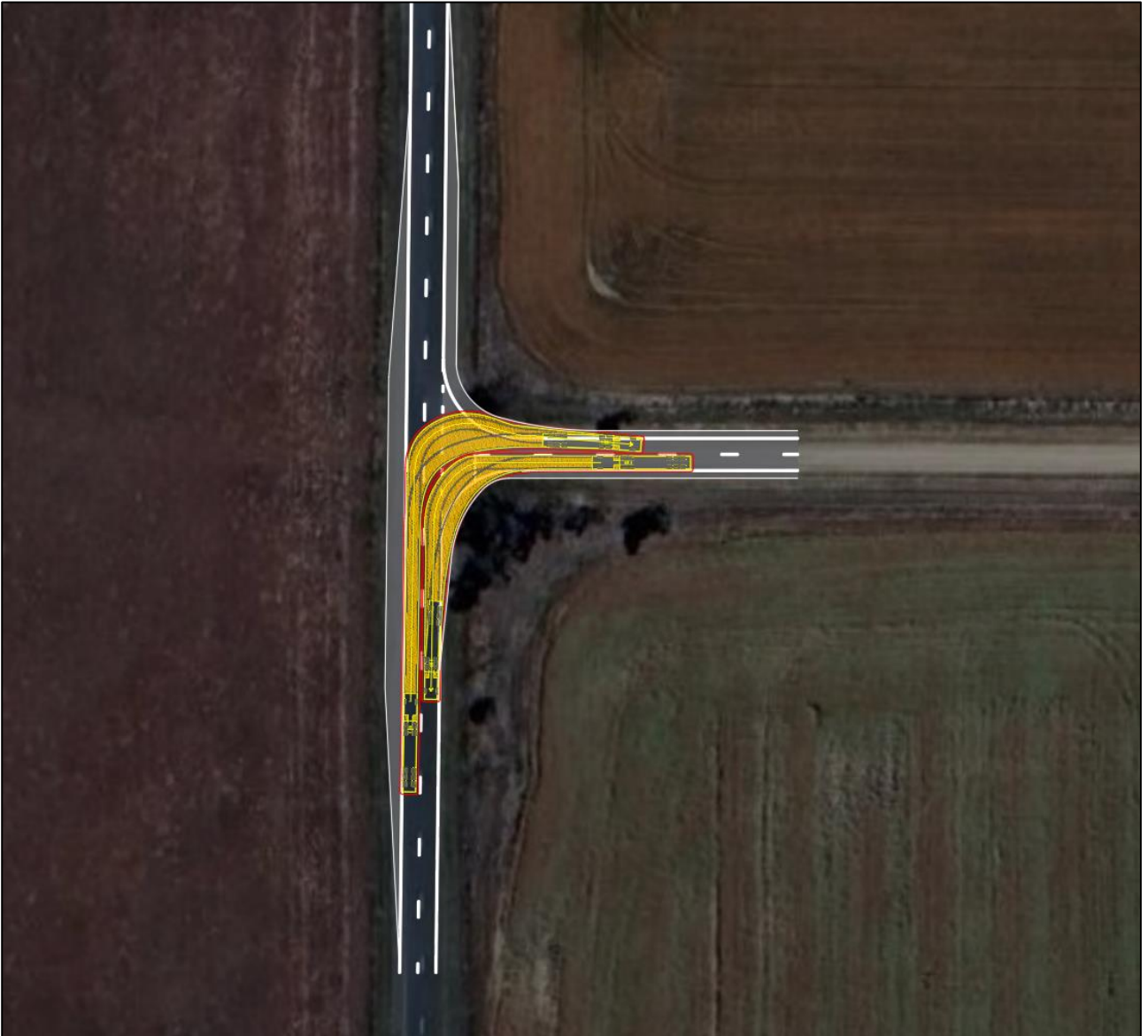

**Figure 8-18: Roslynmead Road / Chrystal Road – 19m AV turn path – Right In / Left Out**

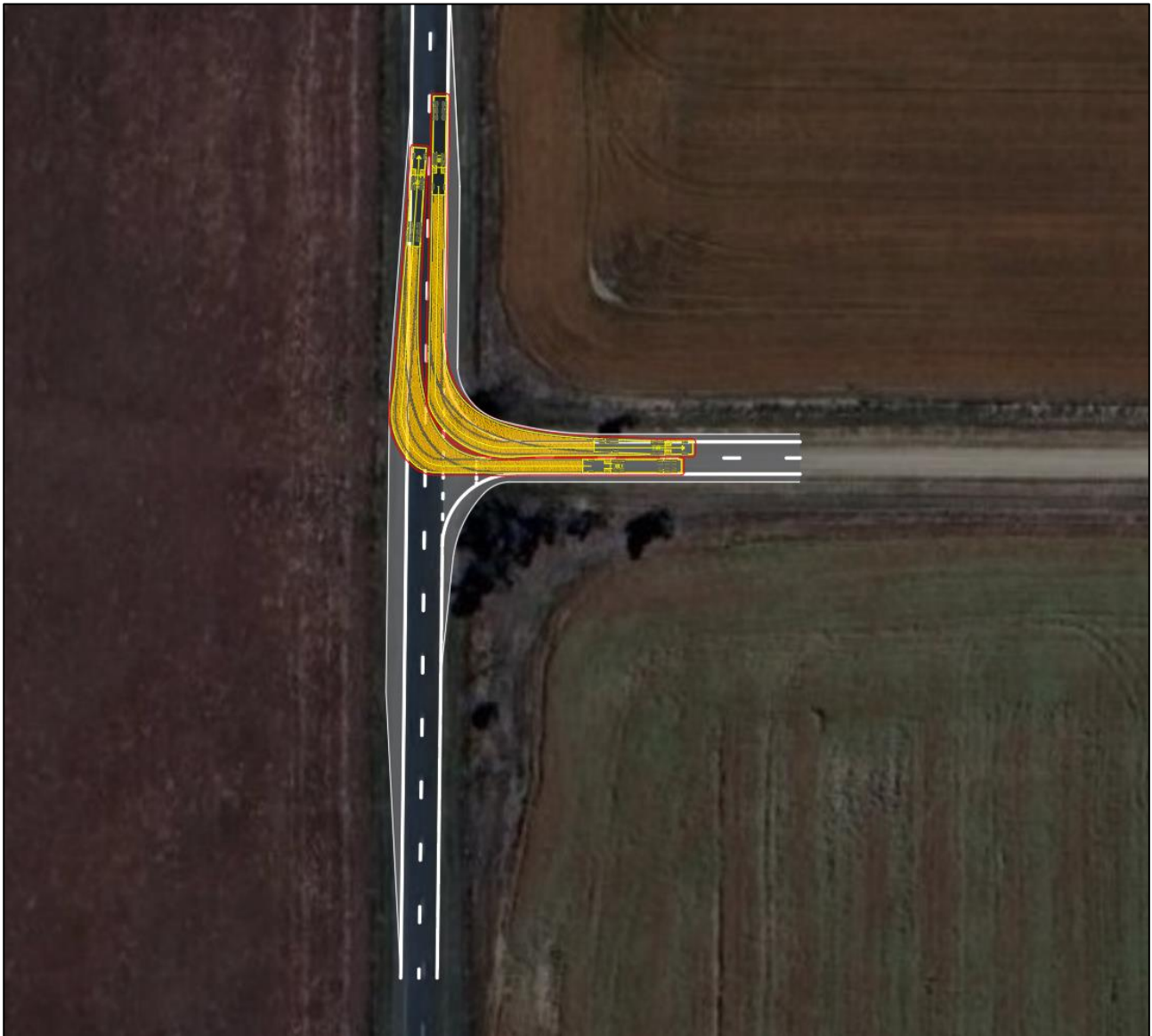

**Figure 8-19: Roslynmead Road / Chrystal Road – 19m AV turn path – Left In / Right Out**

From the above figures, the proposed design geometry of the Roslynmead Road / Chrystal Road intersection can adequately cater for the design vehicle movements.

#### **8.5.5 Baillieu Road / Chrystal Road**

The Baillieu Road / Chrystal Road intersection has been sketched to cater for simple turning movements to cater for two 19m semi-trailers passing each other. As described in **Section 8.4.5**, the eastern portion of the Chrystal Road carriageway, and Baillieu Road carriageway, will be upgraded to a 4m wide single lane sealed pavement and 1.5m gravel shoulders.

The proposed intersection geometry and swept paths for the Baillieu Road / Chrystal Road intersection are shown in **Figure 8-20** and **Figure 8-21**.

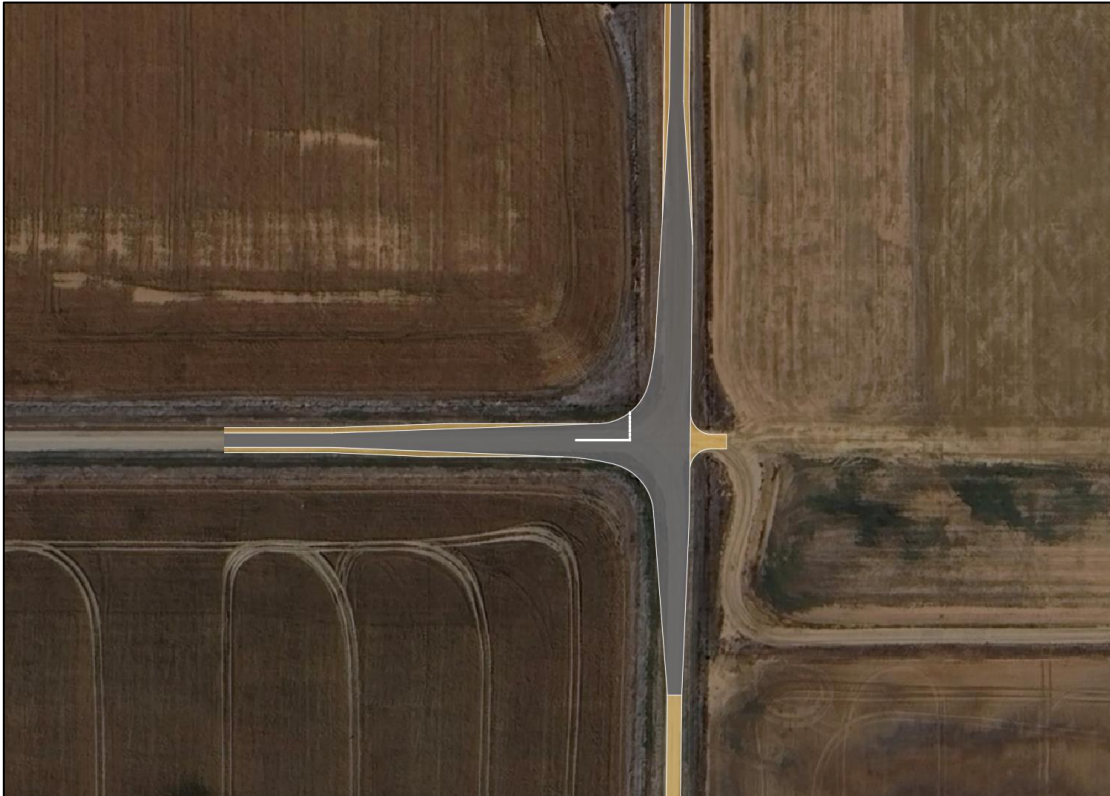

**Figure 8-20: Baillieu Road / Chrystal Road intersection upgrade concept sketch**

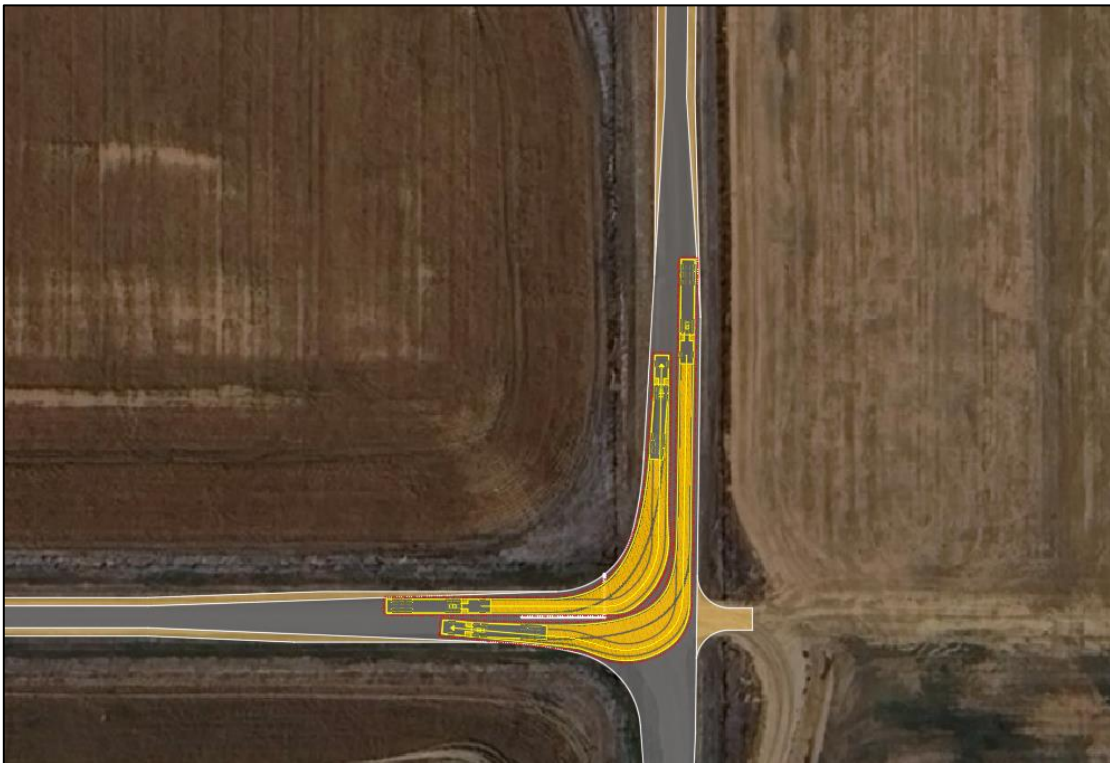

**Figure 8-21: Baillieu Road / Chrystal Road – 19m AV turn path – Right In / Left Out**

From the above figures, the proposed design geometry of the Baillieu Road / Chrystal Road intersection can adequately cater for the design vehicle movements.

### 8.6 Risk assessment

A risk assessment examining the increase in traffic movements relating to the proposed development operation at the relevant key intersections and along the principal traffic route has been considered. The safety risk score matrix used for the assessment is shown in **Figure 8-22**.

		Potential consequence				
		Property only (1)	Minor injury (2)	Medical treatment (3)	Hospitalisation (4)	Fatality (5)
Potential likelihood	Almost certain (5)	M	M	H	H	H
	Likely (4)	M	M	M	H	H
	Moderate (3)	L	M	M	M	H
	Unlikely (2)	L	L	M	M	M
	Rare (1)	L	L	L	M	M

**Figure 8-22: Safety risk score matrix**

With the implementation of the abovementioned intersection provisions, turn warrants outcomes, and road corridor upgrades, and with consideration of the available sight distance and crash data review, no high-risk items or adverse safety issues have been identified that would require further mitigation measures by the development.

## 9. Site layout review

The proposed layout plans for the development sites are detailed at **Appendix A**. The location of the access for each site is illustrated previously in **Section 2.1**. These accesses are separated from adjacent key intersections by a minimum of 800m, well exceeding separation requirements for driveways and intersections on rural access roads.

Gravel access roads and manoeuvring areas are proposed for each of the development sites, to provide internal connections between each of the sheds and associated facilities on site. The proposed internal gravel access roads are 6m wide carriageway with 1m wide shoulders (total 8m formation width). This is considered satisfactory for the required servicing movements of heavy vehicles and traffic volumes associated with the development.

The internal road network is divided into 'clean' and 'dirty' roads which are separated and do not connect to each other for biosecurity provisions.

### 9.1 Site access review

Each of the different development sites propose a sealed intersection throat and turnouts at the intersections with the external road network. These accesses are proposed to be utilised for all vehicle movements into and out of the development site, without any turning restrictions. Sealing the approach, throat and turnouts of the access intersection will mitigate pavement edge wear and migration of gravel onto the adjacent external road through lanes. This will result in lower maintenance requirements at the access locations and also increase safety for motorists utilising the accesses.

It should be noted that the Pollock's Block Rearing Farm access to Davis Road will initially be constructed with a gravel pavement to tie in with the existing form of the Davis Road carriageway. At the time when Davis Road is upgraded to a sealed formation, then it is recommended that the Pollock's Block Rearing Farm access intersection approach, throat and turnouts also be sealed to tie in with the upgraded sealed formation and width of Davis Road.

The accesses will be designed and constructed to Council and IDM standard and to suitably cater for articulated vehicle movements. This will be confirmed during the detailed design phase of the development.

As the sites cater for generally low traffic volumes and no access gate is proposed in the vicinity of the external road network, queuing at each of the sites' accesses are not anticipated to be an issue.

All site accesses are proposed onto Council managed roads, with no access onto DPT roads. It is assumed these access points will be used throughout the development of the site (construction works) as well as for ongoing maintenance access. Site accesses have been proposed to be sealed to mitigate pavement edge wear and transfer of gravel into the road lanes – this is considered a suitable proposal.

## 9.2 Car parking review

### 9.2.1 Car parking requirements

The Campaspe Shire Council Planning Scheme – Clause 52.06-5 stipulates the car parking provisions required for various land uses. However, due to the lack of published parking rates for a poultry Integrated Egg Laying operation within the local planning scheme, the number of required car parking spaces has been conducted through the use of first principles for each of the development sites.

The staff entering the site require one space each (assuming a 20% carpooling rate occurs between staff). Additional provisions have been considered for visitor use at each site.

The proposed parking provided for each site is illustrated in **Table 9-1**.

**Table 9-1: Parking provisions**

Site	Parking Demand (Staff x 20% carpooling)	Parking supply	Surplus
Pollock’s Block Rearing Farm	16 spaces (20 staff)	18 spaces	2 spaces
Warwick’s Block Cage Free Layer Farm	32 spaces (40 staff)	40 spaces	8 spaces
T-Block Free Range Layer Farm	35 spaces (44 staff)	36 spaces	1 space
‘Organic Nutrients’ Composting Facility	4 spaces (5 staff)	7 spaces	3 spaces
<b>Total</b>	<b>87 spaces (109 staff)</b>	<b>101 spaces</b>	<b>14 spaces</b>

**Table 9-1** shows that the parking provision can adequately cater for the expected employee demand for each site with extra surplus spaces that can be used for visitor parking demands. Given the low amount of surplus parking provisions for the T-Block Free Range Layer Farm site, it is recommended that the T-Block Free Range Layer Farm parking be monitored and increased (if required) to allow for additional visitor parking if required in the future.

It is noted that additional car parking is provided internal the site for the ‘clean’ roads and vehicles fleet that remain within the different sites. In addition to this, individual parking locations could also be accommodated near each individual shed locations for operation and maintenance of the sheds.

### 9.2.2 Car parking geometry

The car parking geometry and associated space and aisle dimensions generally comply with the Australian Standards AS2890.1. It is expected to that the car parking layouts be refined further in the detailed design stage for each site.

### 9.2.3 Provisions for persons with disabilities (PWD)

In accordance with the National Construction Code (Part D3.4 – Access for people with a disability) 2022, providing PWD parking for the development would not be applicable of the use and purpose of the development i.e. employment and work which is physically demanding in nature for a poultry Integrated Egg Laying operation. This type of work also could pose a risk for

people with a disability.

As such, no PWD parking spaces are proposed for the development, which is considered acceptable. It is noted however that the parking requirements for the development should be monitored and upgraded to suit any future changes in operation (if any) that allowed opportunity for persons with disabilities to be employed.

#### **9.2.4 Car parking summary**

The proposed car parking facilities are deemed adequate for the proposed development.

Due to the size and greenfield nature of the development land, additional parking could also be accommodated in the vicinity of the proposed car parking areas, as well within other areas of the development sites, if required.

## 10. Implementation plan

This section of the report outlines the identified infrastructure upgrade requirements and designated delivery responsibility. The required upgrades, timing and responsibility of the respective infrastructure items are summarised in **Table 10-1**.

**Table 10-1: Implementation plan – transport infrastructure**

Item	Identified infrastructure upgrade requirement	Timing <sup>1</sup>	Responsibility	Additional commentary and final recommendations <sup>3</sup>
<b>Development infrastructure</b>				
1	<p>Site accesses:</p> <ul style="list-style-type: none"> <li>Pollock’s Block Rearing Farm – Construct site access on Davis Road (standard to match Davis Road formation at the time of construction) - (access to include basic left (BAL) and basic right (BAR) turning provisions).</li> <li>Warwick’s Block Cage-Free Layer Farm – Construct site access on Heppell Road with sealed geometry and turnouts (access to include simple turning provisions).</li> <li>T-Block Free Range Layer Farm – Construct site access on Chrystal Road with sealed geometry and turnouts (access to include basic left (BAL) and basic right (BAR) turning provisions).</li> <li>‘Organic Nutrients’ Composting Facility – Construct site access on Baillieu Road with sealed geometry and turnouts (access to include simple turning provisions).</li> </ul>	At commencement of use of each applicable site (est. 2028)	Developer	<p><b>COMMENTS:</b></p> <p>Nil</p> <p><b>RECOMMENDATION:</b></p> <p>Infrastructure upgrade works to be carried out <i>by the developer</i> in line with the ‘identified infrastructure upgrade requirements’ detailed in this table.</p>
2	Construct internal unsealed road network and parking areas for each site	At commencement of use of each applicable site (est. 2028)	Developer	<p><b>COMMENTS:</b></p> <p>Nil</p> <p><b>RECOMMENDATION:</b></p> <p>Infrastructure upgrade works to be carried out by <i>the developer</i> in line with the ‘identified infrastructure upgrade requirements’ detailed in this table.</p>
3	<p>Provide ongoing monitoring of operations of each site and:</p> <ul style="list-style-type: none"> <li>Maintain internal roads under appropriate schedules</li> <li>Upgrade parking provisions as required to meet staff and visitor demands.</li> </ul>	Ongoing - as required	Developer	<p><b>COMMENTS:</b></p> <p>Nil</p> <p><b>RECOMMENDATION:</b></p> <p>Infrastructure upgrade works to be carried out by <i>the developer</i> in line with the ‘identified infrastructure upgrade requirements’ detailed in this table.</p>

External midblock road infrastructure			
4	Upgrade Davis Road to a sealed 6.2m formation with 1.5m wide shoulders as per Council's planning between Murray Valley Highway and the Pollocks Block Rearing Farm access.	TBC (this is currently required as at 2025)	<p><b>COMMENTS:</b></p> <p>As part of the draft application review process, Council acknowledged that while the existing conditions and usage have been correctly identified in this report, the proposed development will result in increased use of Davis Road. Accordingly, it is recommended that the road be upgraded by the developer to meet relevant Council standards. At a minimum, they advised the developer should provide a financial contribution toward future upgrade works.</p> <p>In response, it is acknowledged that the proposal will lead to increased use of the road. However, the operational and safety assessments undertaken as part of this Traffic Impact Assessment demonstrate that the additional traffic generated by the development does not introduce new / increased risks or trigger upgrade requirements beyond those already associated with existing traffic volumes. Therefore, the conclusions of the current assessment are considered fair and reasonable for all parties.</p> <p>Nonetheless, in consideration of Council's feedback and in the interest of project timing and outcomes, the developer is agreeable to providing a financial contribution toward future upgrade works. It is proposed that this contribution be calculated based on the proportion of development-generated traffic relative to total projected traffic volumes in 2052. This equates to approximately 20%, which is considered a fair and reasonable contribution.</p> <p><b>RECOMMENDATION:</b></p> <p>Infrastructure upgrade works to be carried out <i>by Council</i> in line with the 'identified infrastructure upgrade requirements' detailed in this table.</p> <p>A financial contribution of approximately 20% to be provided by the developer toward these future upgrade works. This contribution can be negotiated during later project stages and formalised through an infrastructure agreement.</p>
5	Upgrade Heppell Road to a sealed 6.2m formation with 1.5m wide shoulders between the Murray Valley Highway and Warwick's Block Cage-Free Layer Farm access.	At commencement of use of Warwick's Block site (est. 2028)	<p><b>COMMENTS:</b></p> <p>Nil</p> <p><b>RECOMMENDATION:</b></p> <p>Infrastructure upgrade works to be carried out by <i>the developer</i> in line with the 'identified infrastructure upgrade requirements' detailed in this table.</p>
6	Upgrade Chrystal Road: <ul style="list-style-type: none"> <li>▪ To a sealed 6.2m formation with 1.5m wide shoulders between Roslynmead Road and T-Block Free Range Layer Farm access</li> <li>▪ To a sealed 4m formation with 1.5m gravel shoulders between the T-Block Free Range Layer Farm access and Baillieu Road.</li> </ul>	At commencement of use of T-Block and 'Organic Nutrients' Composting Facility sites (est 2028)	<p><b>COMMENTS:</b></p> <p>Nil</p> <p><b>RECOMMENDATION:</b></p> <p>Infrastructure upgrade works to be carried out by <i>the developer</i> in line with the 'identified infrastructure upgrade requirements' detailed in this table.</p>

7	Upgrade Baillieu Road to a sealed 4m formation with 1.5m gravel shoulders between Chrystal Road and the 'Organic Nutrients' Composting Facility site access. Include appropriate curve widening for the 120 degree curve in Baillieu Road.	At commencement of use of 'Organic Nutrients' Composting Facility site (est 2028)	Developer	<p><b>COMMENTS:</b></p> <p>Nil</p> <p><b>RECOMMENDATION:</b></p> <p>Infrastructure upgrade works to be carried out by <i>the developer</i> in line with the 'identified infrastructure upgrade requirements' detailed in this table.</p>
<b>External intersection infrastructure</b>				
8	<p><u>Murray Valley Highway / Davis Road</u></p> <p>Upgrade intersection to include basic left (BAL) and basic right (BAR) turning provisions.</p>	TBC (this is currently triggered as at 2025)	Transport for Victoria	<p><b>COMMENTS:</b></p> <p>As part of the draft application review process, Council acknowledged that while the existing conditions and usage have been correctly identified in this report, the proposed development will result in increased use of Davis Road. Accordingly, they recommended that the Murray Valley Highway and Davis Road intersection be upgraded by the developer or at a minimum, they advised the developer should provide a financial contribution toward future intersection upgrade works.</p> <p>Transport for Victoria also indicated that provision for basic left turn treatment (BAL) into Davis Road should be provided at the Murray Valley Highway and Davis Road intersection.</p> <p>In response, it is acknowledged that the proposal will lead to increased use of the Murray Valley Highway and Davis Road intersection. However, the operational and safety assessments undertaken as part of this Traffic Impact Assessment demonstrate that the additional traffic generated by the development does not introduce new / increased risks or trigger upgrade requirements beyond those already associated with existing traffic volumes. Therefore, the conclusions of the current assessment are considered appropriate, and fair and reasonable for all parties.</p> <p>Nonetheless, in consideration of feedback from the referral agencies and in the interest of project timing and outcomes, the developer is agreeable to delivering the upgrade works as requested by Council and Transport for Victoria.</p> <p><b>RECOMMENDATION:</b></p> <p>Infrastructure upgrade works to be carried out <i>by the developer</i> in line with the 'identified infrastructure upgrade requirements' detailed in this table. Timing TBC in line with development delivery schedule.</p>

<p>9</p>	<p><u>Murray Valley Highway / Heppell Road</u> Upgrade intersection to include basic left (BAL) and basic right (BAR) turning provisions.</p>	<p>At commencement of use of Warwick's Block site (est. 2028)</p>	<p>Developer</p>	<p><b>COMMENTS:</b></p> <p>As part of the draft application review process, Transport for Victoria indicated that provision of a channelised right-turn (CHR) treatment into Heppell Road should be considered for implementation by the developer.</p> <p>In response, it is considered that this requirement exceeds what is identified through the operational and safety assessments presented in this report. A review of crash data over the past 15 years does not reveal any patterns that would warrant full-length channelisation. In the absence of reactive safety concerns, turn treatment warrants have been used to determine the appropriate intersection upgrades.</p> <p>Based on these warrants, the recommended treatments—basic left-turn (BAL) and basic right-turn (BAR)—are considered to be fair and reasonable for all parties. Accordingly, it is maintained that these treatments represent an appropriate and proportionate response to the projected traffic demands.</p> <p><b>RECOMMENDATION:</b></p> <p>Infrastructure upgrade works to be carried out <i>by the developer</i> in line with the 'identified infrastructure upgrade requirements' detailed in this table.</p>
<p>10</p>	<p><u>Murray Valley Highway / Roslynmead Road / Bail Road</u> Upgrade intersection to include a full channelised right turn (CHR) treatment into Roslynmead Road, a short channelised right turn (CHR(S)) treatment into Bail Road, and basic left turn (BAL) treatments on each Murray Valley Highway approach.</p>	<p>Existing provisions generally comply with BAR and BAL provisions for turning movements into Roslynmead Road. Channelisation of this intersection is triggered in 2031 without any development influence<sup>2</sup></p>	<p>Transport for Victoria</p>	<p><b>COMMENTS:</b></p> <p>As part of the draft application review process, Transport for Victoria indicated that provision of a channelised left-turn (CHL) treatment into Roslynmead Road should be considered for implementation by the developer.</p> <p>In response, it is considered that this requirement exceeds what is identified through the operational and safety assessments presented in this report. A review of crash data over the past 15 years does not reveal any patterns that would warrant full-length channelisation. In the absence of reactive safety concerns, turn treatment warrants have been used to determine the appropriate intersection upgrades.</p> <p>Based on these warrants, the recommended treatments— full channelised right turn (CHR) treatment and basic left turn (BAL) into Roslynmead Road—are considered to be fair and reasonable for all parties. Accordingly, it is maintained that these treatments represent an appropriate and proportionate response to the projected traffic demands.</p> <p>Additionally, it is recognised that there is no funding available for the future upgrade works. Therefore, considering this along with the feedback from the referral agencies, and in the interest of project timing and outcomes, the developer is agreeable to delivering the future upgrade works in line with the 'identified infrastructure upgrade requirements' detailed in this table. i.e. Upgrade intersection in 2031 to include a full channelised right turn (CHR) treatment into Roslynmead Road, a short channelised right turn (CHR(S)) treatment into Bail Road, and basic left turn (BAL) treatments on each Murray Valley Highway approach.</p> <p><b>RECOMMENDATION:</b></p> <p>Infrastructure upgrade works to be carried out by <i>the developer</i> in line with the 'identified infrastructure upgrade requirements' detailed in this table. Timing TBC in line with development delivery schedule.</p>

11	<u>Roslynmead Road / Chrystal Road</u> Upgrade intersection to include basic left (BAL) and basic right (BAR) turning provisions.	At commencement of use of T-Block and 'Organic Nutrients' Composting Facility sites (est 2028)	Developer	<b>COMMENTS:</b> Nil <b>RECOMMENDATION:</b> Infrastructure upgrade works to be carried out by <i>the developer</i> in line with the 'identified infrastructure upgrade requirements' detailed in this table.
12	<u>Baillieu Road / Chrystal Road</u> Upgrade intersection to a sealed geometry that caters for simple turning movements.	At commencement of use of 'Organic Nutrients' Composting Facility site (est 2028)	Developer	<b>COMMENTS:</b> Nil <b>RECOMMENDATION:</b> Infrastructure upgrade works to be carried out by <i>the developer</i> in line with the 'identified infrastructure upgrade requirements' detailed in this table.

<sup>1</sup>The accesses and construction staging of the development is subject to change. Therefore, the timing of the accesses and relevant development infrastructure will be dependent on the staging identified during the future detailed design stage and construction scheduling of the development.

<sup>2</sup>No mitigation measures are triggered by the development as the development does not cause the requirement for additional turning treatments above what is already required by the background traffic volumes.

<sup>3</sup>This information has been included to address feedback / comments provided by DTP and referral agencies as part of the draft planning permit application submission.

The above developer recommendations for the proposed development sites are illustrated in **Figure 10-1**, with reference to each applicable item in **Table 10-1**.

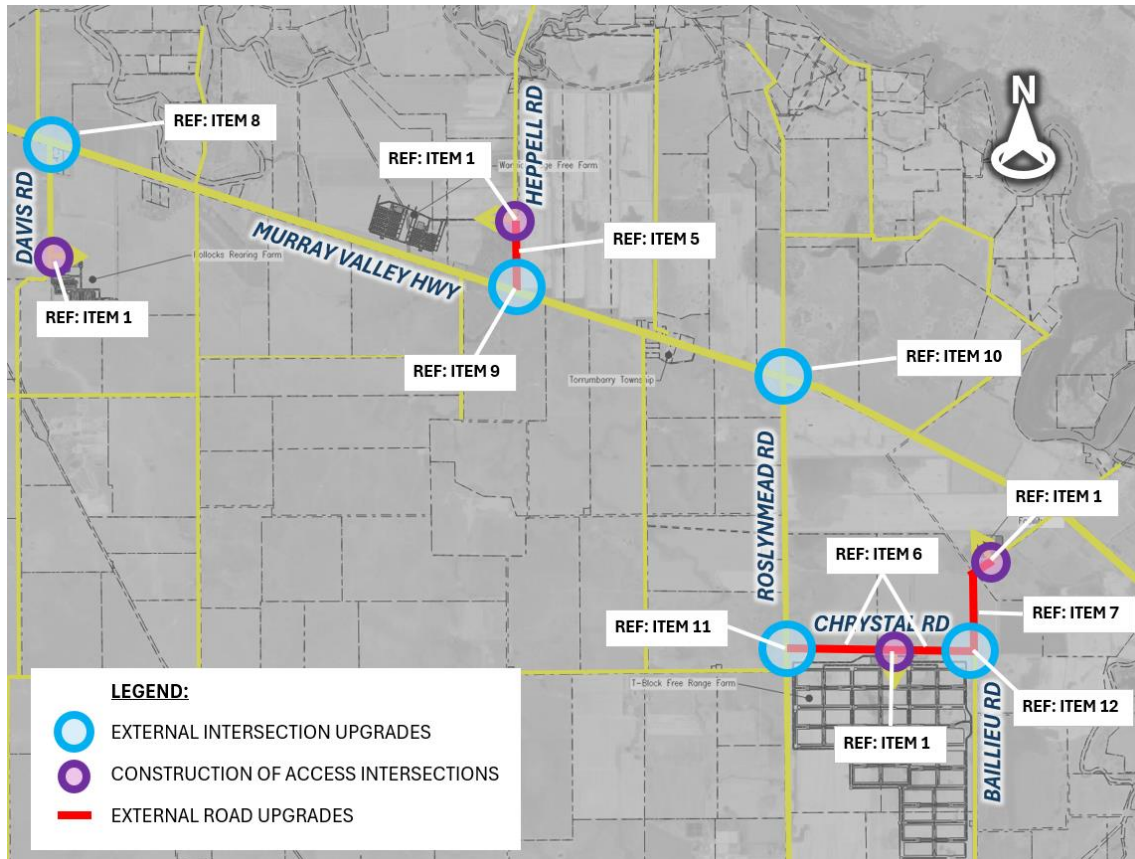

**Figure 10-1: Recommended developer upgrades to the surrounding road network**

## 11. Summary and recommendations

RMA Engineers has been engaged by McLean Farms Australia Pty Ltd (the Client) to undertake a Traffic Impact Assessment (TIA) in support of development applications for a proposed poultry Integrated Egg Laying operation located in Torrumbarry, Victoria.

The proposed development includes the following sites:

- Chick rearing farm, referred to as Pollock's Block Rearing Farm (720,000 birds)
- Cage-free laying farm, referred to as Warwick's Block Cage Free Layer Farm (1,280,000 birds)
- Free-range laying farm, referred to as T-Block Free Range Layer Farm (800,000 birds)
- Composting facility, referred to as 'Organic Nutrients' Composting Facility

The proposed infrastructure will include a total of 36 laying sheds, 16 cage-free and 20 free-range, and 18 rearing sheds with associated ancillary infrastructure.

This report has been prepared in support of the development applications for the proposed Integrated Egg Laying operation. Three separate development applications will be lodged concurrently for assessment by the Victorian Minister for Planning.

This traffic impact assessment has been undertaken in general accordance with the road transport related requirements identified in Austroads Guide to Traffic Management – Part 12: *Integrated Transport Assessments for Developments (2020)*.

The following is a summary of the findings and recommendations of the TIA.

### **Operational impacts:**

- The development as a whole is expected to generate 107 light vehicles and 49 heavy vehicles per day. These vehicles will be dispersed between the four sites, and the arrival/departure of heavy vehicles will be distributed throughout the day.
- It was identified that the external road network peak hours (AM and PM) do not coincide with the peak hours of the development traffic movements at the key intersections. For the purpose of the operational analysis and turn warrant assessment, three assessment scenarios were assessed for the different peak hours throughout the weekday: Network Peak (AM and PM), Development Peak 1 (AM and PM) and Development Peak 2 (AM and PM).
- Given the low anticipated ultimate 2052 'background with development' traffic volumes, intersection analysis is not deemed warranted for the key intersection locations.
- Regardless of the above, SIDRA analysis undertaken at the key intersection indicates that all intersections operate well below the DSS with minimal saturation, delays and queues for the 2052 ultimate development, for the three key peak scenarios. In addition to this, no individual movements exceed the 42-second delay threshold for unacceptable delay related to priority-controlled intersections.
- The development impact on the key external intersections do not cause any adverse operational issues. The intersections operate well within performance thresholds and therefore, no mitigation of operational impacts or upgrades are required for the key external intersections.

- The mid-block level of service for the surrounding road network is LoS B for the Murray Valley Highway and LoS A for all other key roads under the 2052 ultimate development scenarios. No upgrades are required on the surrounding external road network with regards to operational capacity.

**Safety considerations:**

- From a historical crash data review, no crash patterns or mitigation measures could be identified within the vicinity of the sites or along the primary traffic routes. It is recommended that ongoing monitoring of crashes in the area be conducted by the relevant road authority to determine crash patterns and relevant mitigation measures in the future.
- The turn warrant assessment suggests that:
  - › All the key intersections fall within basic turn treatment thresholds (i.e. BAL and BAR), with the exception of Murray Valley Highway / Roslynmead Road / Bail Road which triggers a CHR turn treatment for vehicles turning into Roslynmead Road. This is required in the background scenario, regardless of the development. It is noted that this is similar for the 2042 completion year where the background volumes trigger CHR(S) turn treatment and the addition of the development traffic does not trigger any treatment greater than this.
  - › No mitigation measures are triggered by the development at the existing external key intersections as the development does not cause the requirement for additional turning treatments above what is already required by the background traffic volumes.
  - › As per the turn warrant assessment outcomes, all new accesses and intersections should be constructed with consideration of basic turning treatments (BAL and BAR).
- The sight distance assessment found that sight distance available at the key intersections is satisfactory and meets the minimum SISD requirements for all approaches.
- Given the relatively flat terrain and surrounding topography of the area, it is expected that the sight distance at each access location would meet relevant sight distance requirements. The sight distance of these accesses can be confirmed and appropriately designed during future detailed design phase of the development for each site.
- A review of the suitability of the surrounding road network indicates the following:
  - › Murray Valley Highway - The Murray Valley Highway has suitable road geometry and sufficient sight lines available along the length of the road corridor, in the vicinity of the subject sites. From a desktop review, the existing cross section, pavement and road environment along the Murray Valley Highway is deemed suitable for development traffic. No mitigation measures or upgrades are deemed to be required by the development along the subject length of the Murray Valley Highway.
  - › Roslynmead Road - Roslynmead Road pavement appears to be in good condition for a rural collector road. The road has suitable road geometry and sufficient sight lines available along the length of the road corridor, in the vicinity of the subject sites.

Minor edgewear is evident at intermittent locations along the corridor. From a desktop review, the existing cross section, pavement and road environment along Roslynmead Road is deemed suitable for development traffic.

It is recommended that the condition of Roslynmead Road be monitored. At this time, no mitigation measures or upgrades are deemed to be required by the development along the subject length of Roslynmead Road.

- › Heppell Road - Heppell Road is currently signed as a 'Dry Weather Road Only' and comprises an unsealed earth carriageway. The unsealed pavement at the intersection with the Murray Valley Highway has deep wheel rutting and ponding which is not suitable for safe traffic movement.

It is recommended the developer upgrades Heppell Road to a rural access road, including a 6.2m wide seal with 1.5m shoulders in line with the Campaspe Shire Council requirements.

- › Davis Road - The existing form of the gravel portion of Davis Road appears to be in good condition, with suitable road geometry and sufficient sight lines available along the entire length of the road between the Murray Valley Highway and the proposed site access for Pollock's Block Rearing Farm.

Given that this road is used by heavy vehicles accessing the Veolia Patho Landfill site, and that the background volumes at the 2042 design year will be greater than 150 vehicles per day (vpd), it is recommended that Council upgrade Davis Road to a rural access road (with 6.2m wide seal with 1.5m shoulders), in line with the Campaspe Shire Council requirements. This is also consistent with Council's current plans and intent for the upgrade of Davis Road.

Therefore, no mitigation measures or upgrades are deemed to be required by the development along the subject length of Davis Road.

- › Chrystal Road - The existing form of Chrystal Road is an unsealed carriageway varying between approximately 4-6m wide. The terrain is flat, with sufficient sight lines available along the entire length of the road between the Roslynmead Road and Baillieu Road.

Chrystal Road is the primary access road to the T-Block Free Range Layer Farm and the 'Organic Nutrients' Composting Facility and similar to Heppell Road, it is recommended that Chrystal Road is upgraded to local access road standards:

- It is recommended that the western section of road be upgraded to a 6.2m wide seal with 1.5m shoulders, in line with the Campaspe Shire Council requirements.
- It is recommended that the eastern section of road be upgraded to a 4m wide single lane sealed pavement and 1.5m gravel shoulders, inline with the Campaspe Shire Council requirements.

- › Baillieu Road - The existing form of Baillieu Road is an unsealed carriageway varying between approximately 4-6m wide. The terrain is flat, with sufficient sight lines available along the entire length of the road.

All manure collections from the associated farms are expected to travel to the 'Organic Nutrients' Composting Facility via Baillieu Road. Therefore, it is recommended that Baillieu Road is upgraded to a 4m wide single lane sealed pavement and 1.5m gravel shoulders, between Chrystal Road and the 'Organic Nutrients' Composting Facility access, inline with the Campaspe Shire Council requirements.

- › It is noted that there is a 120 degree curve in Baillieu Road located approximately 850m north of Chrystal Road. It is recommended that the pavement at this location be widened to accommodate two vehicles passing.
- A review of the suitability of the surrounding intersections was undertaken with provision of the turn warrant outcomes and swept path assessment of a 19m AV. The recommended geometries and layouts illustrated in conceptual sketches in **Section 8.5** of this report (and detailed in **Appendix H**) can adequately cater for the design vehicle movements.
- From a risk assessment it was identified that with the implementation of the recommended intersection provisions, turn warrants outcomes, and road corridor upgrades, and with consideration of the available sight distance and crash data review, no high-risk items or adverse safety issues have been identified that would require further mitigation measures by the development.

**Site layout review:**

- The proposed access locations are separated from adjacent key intersections by a minimum of 800m, well exceeding separation requirements for driveways and intersections on rural access roads.
- Gravel access roads and manoeuvring areas are proposed for each of the development sites, to provide internal connections between each of the sheds and associated facilities on site. The proposed internal gravel access roads are considered satisfactory for the required servicing movements of heavy vehicles and traffic volumes associated with the development.
- The internal road network is divided into 'clean' and 'dirty' roads which are separated and do not connect to each other for biosecurity provisions.
- It is recommended that each access provide a sealed approach, throat and turnouts of the access intersection to help mitigate future pavement edge wear and migration of gravel onto the adjacent external road through lanes.
- The accesses will be designed and constructed to relevant Council and IDM standards, and to suitably cater for articulated vehicle movements. This will be confirmed during the detailed design phase of the development.
- As the sites cater for generally low traffic volumes and no access gate is proposed in the vicinity of the external road network, queuing at each of the sites' accesses is not anticipated to be an issue.
- The parking provision can adequately cater for the expected employee demand for each site with extra surplus spaces that can be used for visitor parking demands.
- Given the low amount of surplus parking provisions for the T-Block Free Range Layer Farm site, it is recommended that the T-Block Free Range Layer Farm parking be monitored and increased (if required) to allow for additional visitor parking if required in the future.
- It is noted that additional car parking is provided internal to the sites for the 'clean' roads and dedicated vehicle fleets within the different sites. In addition to this, individual parking locations could also be accommodated near each individual shed locations for operation and maintenance of the sheds.

- The car parking geometry and associated space and aisle dimensions generally comply with the Australian Standards AS2890.1. It is expected that the car parking layouts will be refined further in the detailed design stage for each site.
- In accordance with the National Construction Code, no PWD parking spaces are proposed for the development, which is considered acceptable. It is noted however that the parking requirements for the development should be monitored and upgraded to suit any future changes in operation (if any) that allowed opportunity for persons with disabilities to be employed.
- The proposed car parking facilities are deemed adequate for the proposed development. Due to the size and greenfield nature of the development land, additional parking could also be accommodated in the vicinity of the proposed car parking areas, as well within other areas of the development sites, if required.

**Implementation of identified infrastructure upgrades:**

- The recommended upgrades, timing and responsibility of the respective infrastructure items are summarised in **Table 10-1**.
- **Figure 10-1** illustrates the recommended developer upgrades for the proposed development sites.

With respect to the above findings and implementation of the recommendations of this TIA report, the proposed development can proceed without any unacceptable or adverse impacts on the external road network. No traffic and transport engineering matters have been identified that should preclude approval of the proposed development at the specified locations.

## Appendix A Development layout

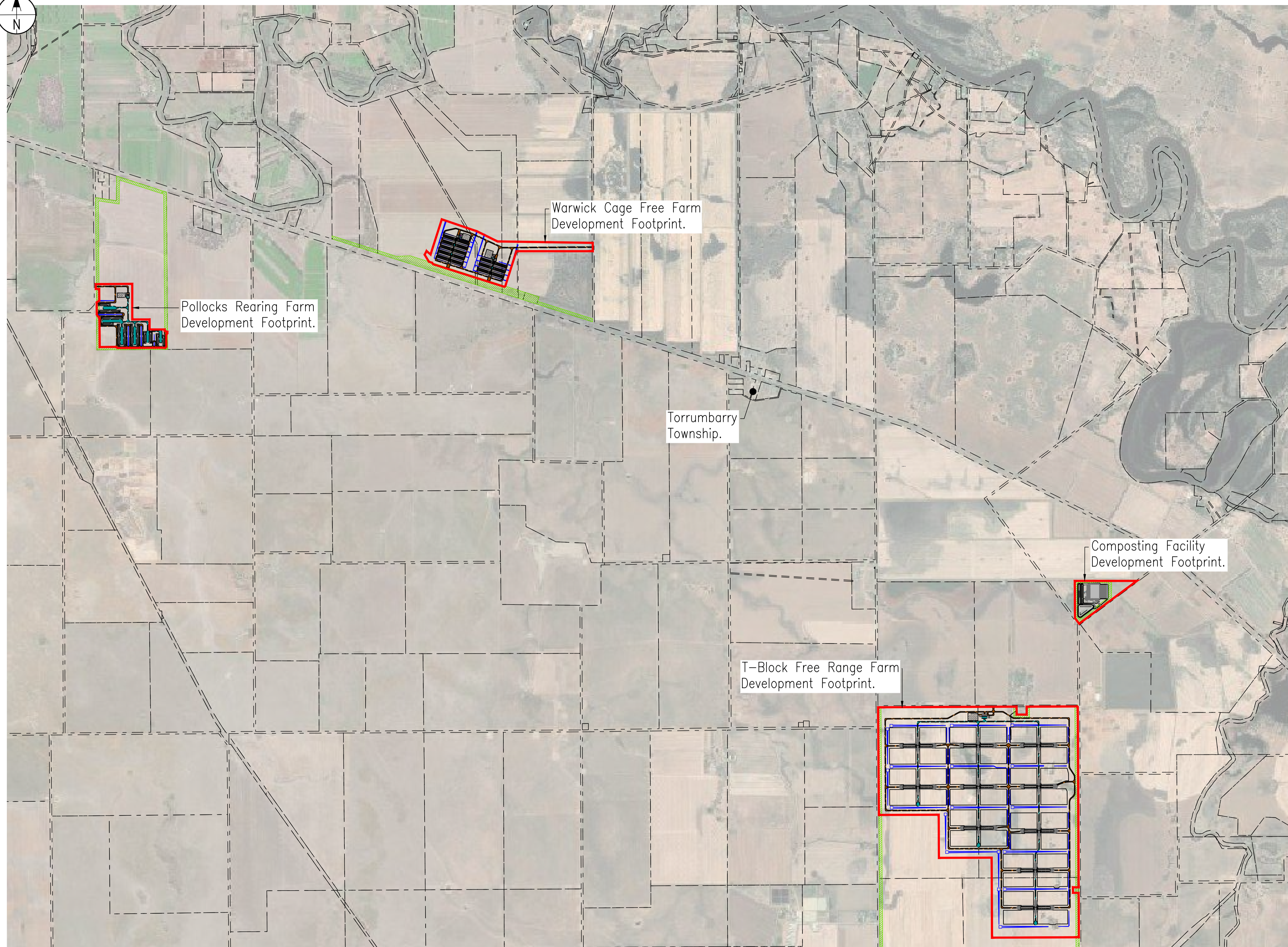
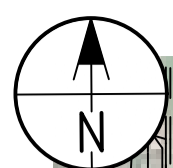

**LEGEND:**  
EXISTING

- Property Boundary
- Farm Development Footprints

**PLAN NOTES:**

P.1. Plan is intended to be viewed in colour.

**DISCLAIMER NOTES:**

- D.1. This is a sketch plan only and is conceptual only.
- D.2. This sketch plan represents design intent and concepts only.
- D.3. Information shown on these plans has been compiled from varying sources and may not be accurate and will need verifying. This includes imagery, existing infrastructure, property boundaries and natural surface data.
- D.4. No reliance should be placed on the information on this plan for detailed design or any financial dealings involving this land.
- D.5. This plan shall not be used for tendering, financing, ordering of materials, construction or any other unintended purpose.

# OVERALL CONCEPT LAYOUT PLAN

Scale 1:20000 (A1)

0 200 400 600 800m  
1:20000(A1) 1:40000(A3)

ISSUE	DESCRIPTION	DATE	DWN	DES	CHK	APP
I	FOR INFORMATION	12/08/25	BLL	BLL	ALB	-
H	FOR INFORMATION	28/07/25	BLL	BLL	ASO	-
G	FOR INFORMATION	23/07/25	BLL	BLL	ALB	-
F	FOR COMMENT	21/07/25	LMB	BLL	ALB	-
E	FOR COMMENT	24/06/25	BLL	BLL	ALB	-
D	FOR COMMENT	24/06/25	LMB	BLL	ASO	-
C	FOR COMMENT	20/06/25	BLL	BLL	BLL	-
1	FOR APPROVAL	16/10/25	BLL	BLL	GS	-
0	FOR APPROVAL	16/08/25	BLL	BLL	GS	-

THIS DOCUMENT IS UNCONTROLLED AND IS NOT TO BE USED FOR CONSTRUCTION UNTIL THIS NOTE IS REMOVED AND A DIGITAL SIGNATURE PROVIDED IN ITS PLACE



**CLIENT**  
**MCLEAN FARMS AUSTRALIA PTY LTD**  
 PO BOX 158  
 PITTSWORTH, QLD, 4356

**PROJECT**  
**INTEGRATED EGG LAYING OPERATION**  
**MURRAY VALLEY HIGHWAY**  
**TORRUMBARRY, VIC, 3562**

**TITLE**  
**OVERALL CONCEPT LAYOUT PLAN**

HEIGHT DATUM <b>AHD</b>	MAP GRID <b>VICGRID</b>	SIZE <b>A1</b>
COUNCIL RAL/MCU NO.		
COUNCIL OW NO.		
PROJECT NO. <b>25E-0010</b>	DRAWING NO. <b>C-SK0003</b>	ISSUE <b>1</b>

COPYRIGHT RMA ENGINEERS PTY LTD ©

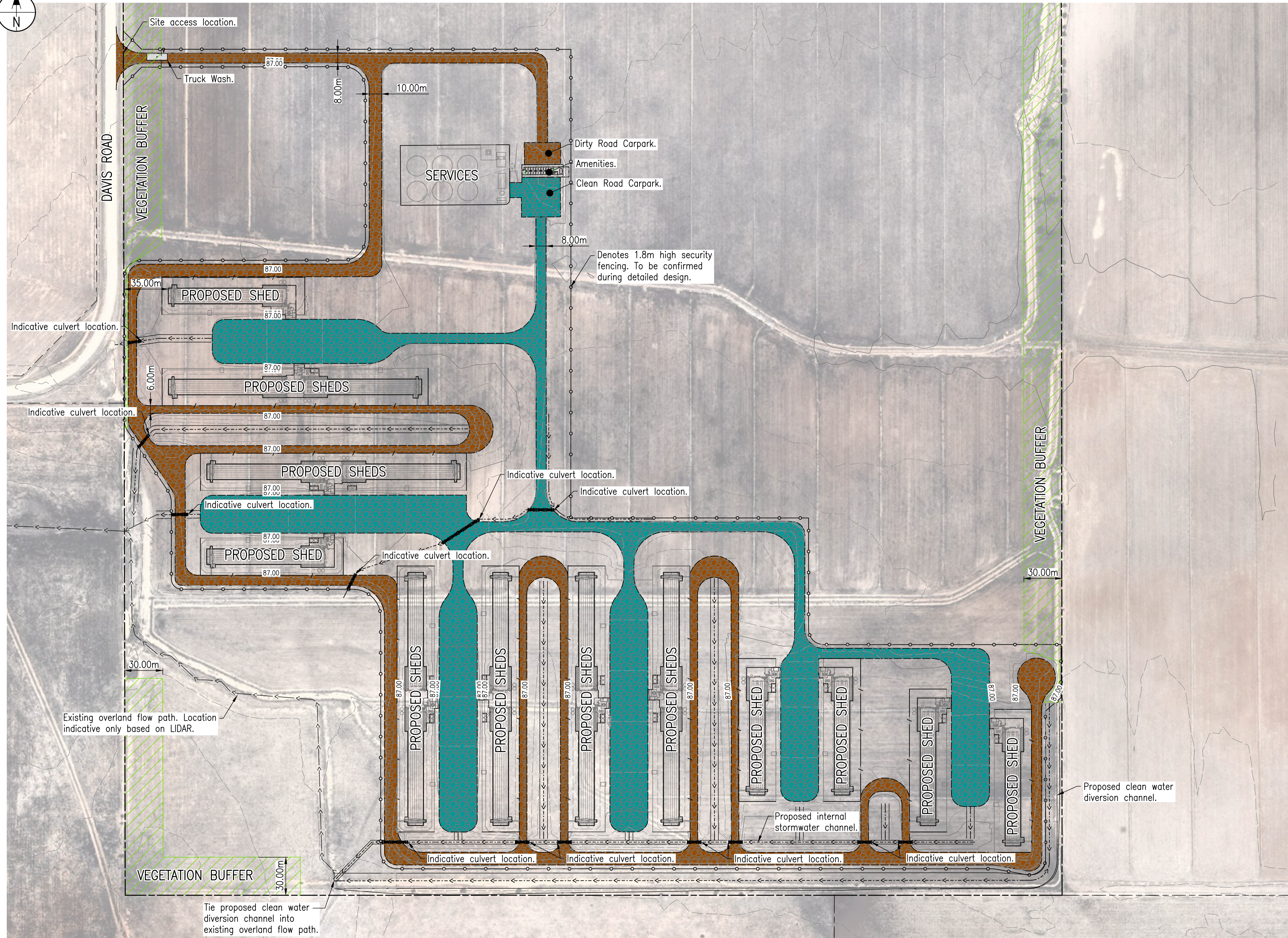
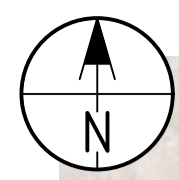

- LEGEND:**
- EXISTING**
- → → → Invert
  - - - - - Property Boundary
- PROPOSED**
- Clean Area Road Pavement
  - Dirty Area Road Pavement
  - Vegetation Buffer
  - - - - - Property Boundary
  - - - - - Minor Contours
  - 609.00 — Major Contours
  - → → → Invert
  - (D)--(D)-- Indicative Stormwater Culvert
  - ○ ○ ○ Fence
- PLAN NOTES:**
- P.1. Plan is intended to be viewed in colour.
  - P.2. Intervals between contours - 0.2m. Contours are design surface levels.
- DISCLAIMER NOTES:**
- D.1. This is a sketch plan only and is conceptual only.
  - D.2. This sketch plan represents design intent and concepts only.
  - D.3. Information shown on these plans has been compiled from varying sources and may not be accurate and will need verifying. This includes imagery, existing infrastructure, property boundaries and natural surface data.
  - D.4. No reliance should be placed on the information on this plan for detailed design or any financial dealings involving this land.
  - D.5. This plan shall not be used for tendering, financing, ordering of materials, construction or any other unintended purpose.

# POLLOCK'S BLOCK REARING FARM CONCEPT LAYOUT PLAN

Scale 1:1500 (A1)

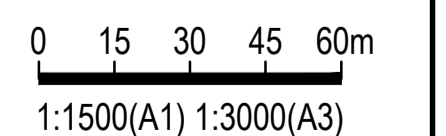

ISSUE	DESCRIPTION	DATE	DWN	DES	CHK	APP
1	FOR APPROVAL	16/10/25	LMB	LMB	GS	
0	FOR APPROVAL	15/08/25	LMB	LMB	GS	
A	FOR COMMENT	13/08/25	LMB	LMB	GS	

R.P.E.Q.  
THIS DOCUMENT IS UNCONTROLLED AND IS NOT TO BE USED FOR CONSTRUCTION UNTIL THIS NOTE IS REMOVED AND A DIGITAL SIGNATURE PROVIDED IN ITS PLACE



CLIENT  
**MCLEAN FARMS AUSTRALIA PTY LTD**  
PO BOX 158  
PITTSWORTH, QLD, 4356

PROJECT  
**INTEGRATED EGG LAYING OPERATION**  
MURRAY VALLEY HIGHWAY  
TORRUMBARRY, VIC, 3562

TITLE  
**POLLOCK'S BLOCK REARING FARM CONCEPT LAYOUT PLAN**

HEIGHT DATUM <b>AHD</b>	MAP GRID <b>VICGRID</b>	SIZE <b>A1</b>
COUNCIL RAL/MCU NO.		
COUNCIL OW NO.		
PROJECT NO. <b>25E-0010</b>	DRAWING NO. <b>P-SK1001</b>	ISSUE <b>1</b>

COPYRIGHT RMA ENGINEERS PTY LTD ©

Copyright © RMA ENGINEERS PTY LTD  
N:\Synergy\Projects\25E-0010 Poultry Farm - Torrumbarry\8 Civil Model and Doc\MASTER DOCUMENTATION\01 Package\Drafting\1P-SK1001.dwg P-SK1001

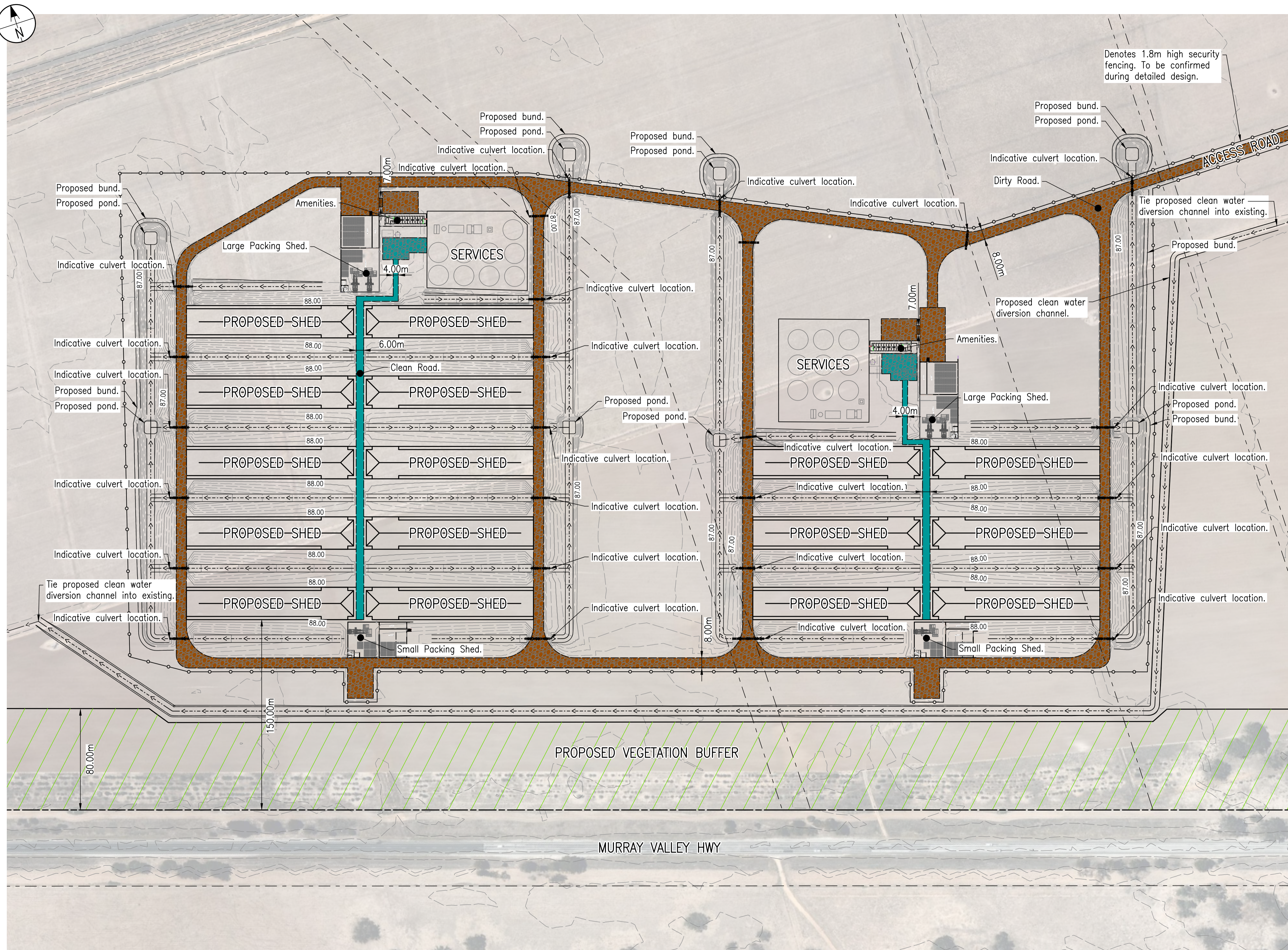
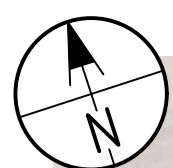

**LEGEND:**

**EXISTING**

- → → Invert
- - - - - Property Boundary

**PROPOSED**

- Clean Area Road Pavement
- Dirty Area Road Pavement
- Vegetation Buffer
- - - - - Property Boundary
- - - - - Minor Contours
- - - - - Major Contours
- - - - - Invert
- - (D) - - (D) - - Indicative Stormwater Culvert
- ○ ○ Fence

**PLAN NOTES:**

P.1. Plan is intended to be viewed in colour.  
P.2. Intervals between contours - 0.2m.  
Contours are design surface levels.

**DISCLAIMER NOTES:**

D.1. This is a sketch plan only and is conceptual only.  
D.2. This sketch plan represents design intent and concepts only.  
D.3. Information shown on these plans has been compiled from varying sources and may not be accurate and will need verifying. This includes imagery, existing infrastructure, property boundaries and natural surface data.  
D.4. No reliance should be placed on the information on this plan for detailed design or any financial dealings involving this land.  
D.5. This plan shall not be used for tendering, financing, ordering of materials, construction or any other unintended purpose.

## WARWICK'S BLOCK CAGE FREE CONCEPT LAYOUT PLAN

Scale 1:1500 (A1)

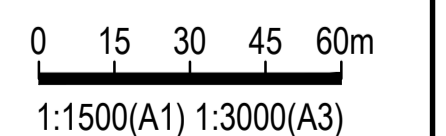

ISSUE	DESCRIPTION	DATE	DWN	DES	CHK	APP
1	FOR APPROVAL	16/10/25	LMB	LMB	GS	
0	FOR APPROVAL	15/08/25	LMB	LMB	GS	
A	FOR COMMENT	08/08/25	LMB	LMB	GS	

R.P.E.Q.  
**THIS DOCUMENT IS UNCONTROLLED AND IS NOT TO BE USED FOR CONSTRUCTION UNTIL THIS NOTE IS REMOVED AND A DIGITAL SIGNATURE PROVIDED IN ITS PLACE**



CLIENT  
**MCLEAN FARMS AUSTRALIA PTY LTD**  
**PO BOX 158**  
**PITTSWORTH, QLD, 4356**

PROJECT  
**INTEGRATED EGG LAYING OPERATION**  
**MURRAY VALLEY HIGHWAY**  
**TORRUMBARRY, VIC, 3562**

TITLE  
**WARWICK'S BLOCK CAGE FREE CONCEPT LAYOUT PLAN**

HEIGHT DATUM <b>AHD</b>	MAP GRID <b>VICGRID</b>	SIZE <b>A1</b>
COUNCIL RAL/MCU NO. -	COUNCIL OW NO. -	
PROJECT NO. <b>25E-0010</b>	DRAWING NO. <b>P-SK2001</b>	ISSUE <b>1</b>

COPYRIGHT RMA ENGINEERS PTY LTD

Copyright © RMA ENGINEERS PTY LTD  
N:\Synergy\Projects\25E-0010 Poultry Farm - Torrumbarry\8 Civil Model and Doc\MASTER DOCUMENTATION\02 Package\Drafting\P-SK2001.dwg P-SK2001

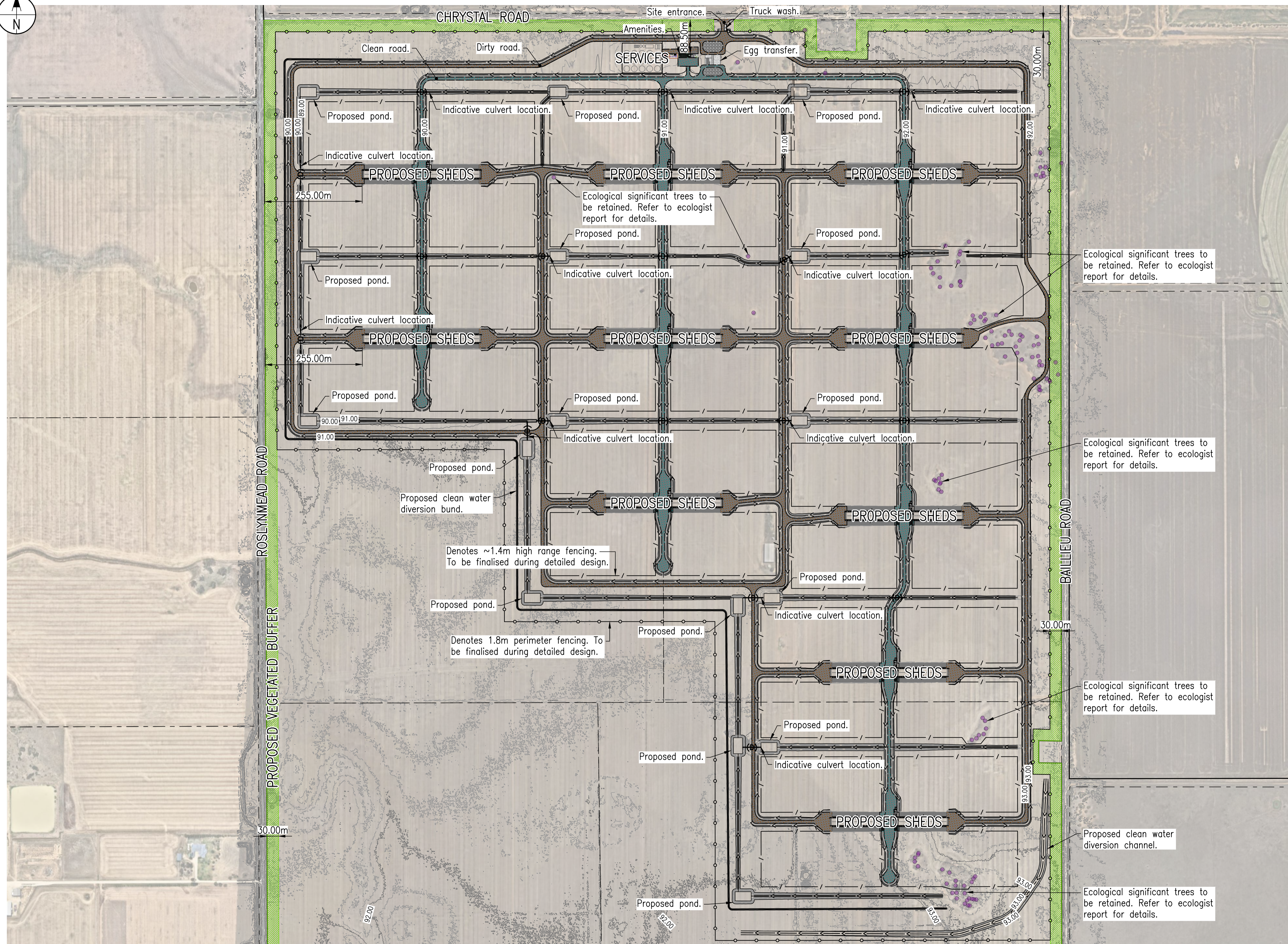
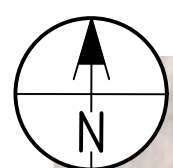

**LEGEND:**

**EXISTING**

- Property Boundary
- - - - Easement Boundary
- Ecologically Significant Tree

**PROPOSED**

- - - - Ranging Fence
- Perimeter Fence
- Stormwater Invert
- (D)--(D)-- Indicative Stormwater Line
- ▨ Vegetation Buffer
- ▨ Clean Area Road Pavement
- ▨ Dirty Area Road Pavement
- ▨ Gravel Pavement
- ▨ Concrete Pavement
- Minor Contours
- 609.00— Major Contours

**PLAN NOTES:**

P.1. Plan is intended to be viewed in colour.  
P.2. Intervals between contours - 0.2m.  
Contours are design surface levels.

**DISCLAIMER NOTES:**

D.1. This is a sketch plan only and is conceptual only.  
D.2. This sketch plan represents design intent and concepts only.  
D.3. Information shown on these plans has been compiled from varying sources and may not be accurate and will need verifying. This includes imagery, existing infrastructure, property boundaries and natural surface data.  
D.4. No reliance should be placed on the information on this plan for detailed design or any financial dealings involving this land.  
D.5. This plan shall not be used for tendering, financing, ordering of materials, construction or any other unintended purpose.

## T-BLOCK FREE RANGE CONCEPT LAYOUT PLAN

Scale 1:5000 (A1)

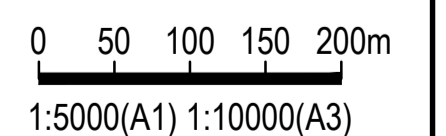

ISSUE	DESCRIPTION	DATE	DWN	DES	CHK	APP
1	FOR APPROVAL	16/10/25	BLL	BLL	GS	
0	FOR APPROVAL	15/08/25	BLL	BLL	GS	
A	FOR COMMENT	08/08/25	BLL	BLL	GS	

R.P.E.Q.  
**THIS DOCUMENT IS UNCONTROLLED AND IS NOT TO BE USED FOR CONSTRUCTION UNTIL THIS NOTE IS REMOVED AND A DIGITAL SIGNATURE PROVIDED IN ITS PLACE**



CLIENT  
**MCLEAN FARMS AUSTRALIA PTY LTD**  
**PO BOX 158**  
**PITTSWORTH, QLD 4356**

PROJECT  
**INTEGRATED EGG LAYING OPERATION**  
**MURRAY VALLEY HIGHWAY**  
**TORRUMBARRY, VIC 3562**

TITLE  
**T-BLOCK FREE RANGE CONCEPT LAYOUT PLAN**

COPYRIGHT RMA ENGINEERS PTY LTD ©

HEIGHT DATUM <b>AHD</b>	MAP GRID <b>VICGRID</b>	SIZE <b>A1</b>
COUNCIL RAL/MCU NO.		
COUNCIL OW NO.		
PROJECT NO. <b>25E-0010</b>	DRAWING NO. <b>P-SK3001</b>	ISSUE <b>1</b>

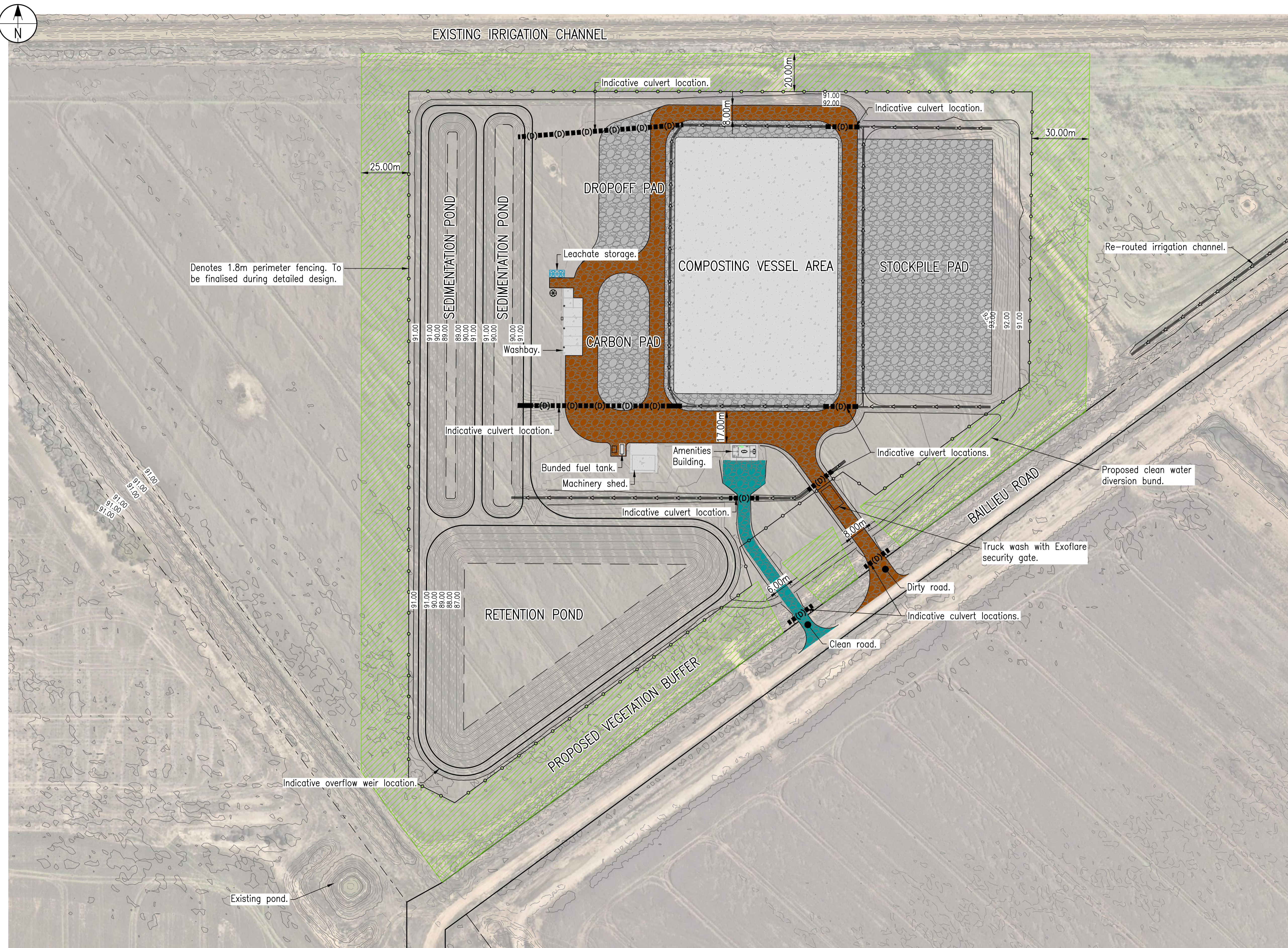

**LEGEND:**

**EXISTING**

- Property Boundary

**PROPOSED**

- Perimeter Fence
- Stormwater Invert
- (D)---(D) Indicative Stormwater Line
- ▨ Vegetation Buffer
- ▨ Clean Area Road Pavement
- ▨ Dirty Area Road Pavement
- ▨ Gravel Pavement
- ▨ Concrete Pavement
- Minor Contours
- 609.00 Major Contours

**PLAN NOTES:**

P.1. Plan is intended to be viewed in colour.  
 P.2. Intervals between contours - 0.2m.  
 Contours are design surface levels.

**DISCLAIMER NOTES:**

D.1. This is a sketch plan only and is conceptual only.  
 D.2. This sketch plan represents design intent and concepts only.  
 D.3. Information shown on these plans has been compiled from varying sources and may not be accurate and will need verifying. This includes imagery, existing infrastructure, property boundaries and natural surface data.  
 D.4. No reliance should be placed on the information on this plan for detailed design or any financial dealings involving this land.  
 D.5. This plan shall not be used for tendering, financing, ordering of materials, construction or any other unintended purpose.

# COMPOSTING FACILITY CONCEPT LAYOUT PLAN

Scale 1:1000 (A1)

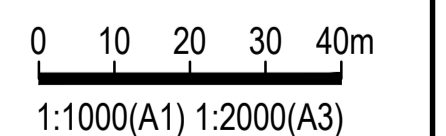

ISSUE	DESCRIPTION	DATE	DWN	DES	CHK	APP
1	FOR APPROVAL	16/10/25	BLL	BLL	GS	
0	FOR APPROVAL	15/08/25	BLL	BLL	GS	
A	FOR COMMENT	08/08/25	BLL	BLL	GS	

R.P.E.Q.  
 THIS DOCUMENT IS UNCONTROLLED AND IS NOT TO BE USED FOR CONSTRUCTION UNTIL THIS NOTE IS REMOVED AND A DIGITAL SIGNATURE PROVIDED IN ITS PLACE



CLIENT  
**MCLEAN FARMS AUSTRALIA PTY LTD**  
 PO BOX 158  
 PITTSWORTH, QLD 4356

PROJECT  
**INTEGRATED EGG LAYING OPERATION**  
**MURRAY VALLEY HIGHWAY**  
**TORRUMBARRY, VIC 3562**

TITLE  
**COMPOSTING FACILITY CONCEPT LAYOUT PLAN**

HEIGHT DATUM <b>AHD</b>	MAP GRID <b>VICGRID</b>	SIZE <b>A1</b>
COUNCIL RAL/MCU NO.		
COUNCIL OW NO.		
PROJECT NO. <b>25E-0010</b>	DRAWING NO. <b>P-SK4001</b>	ISSUE <b>1</b>

## Appendix B Proposed travel route maps

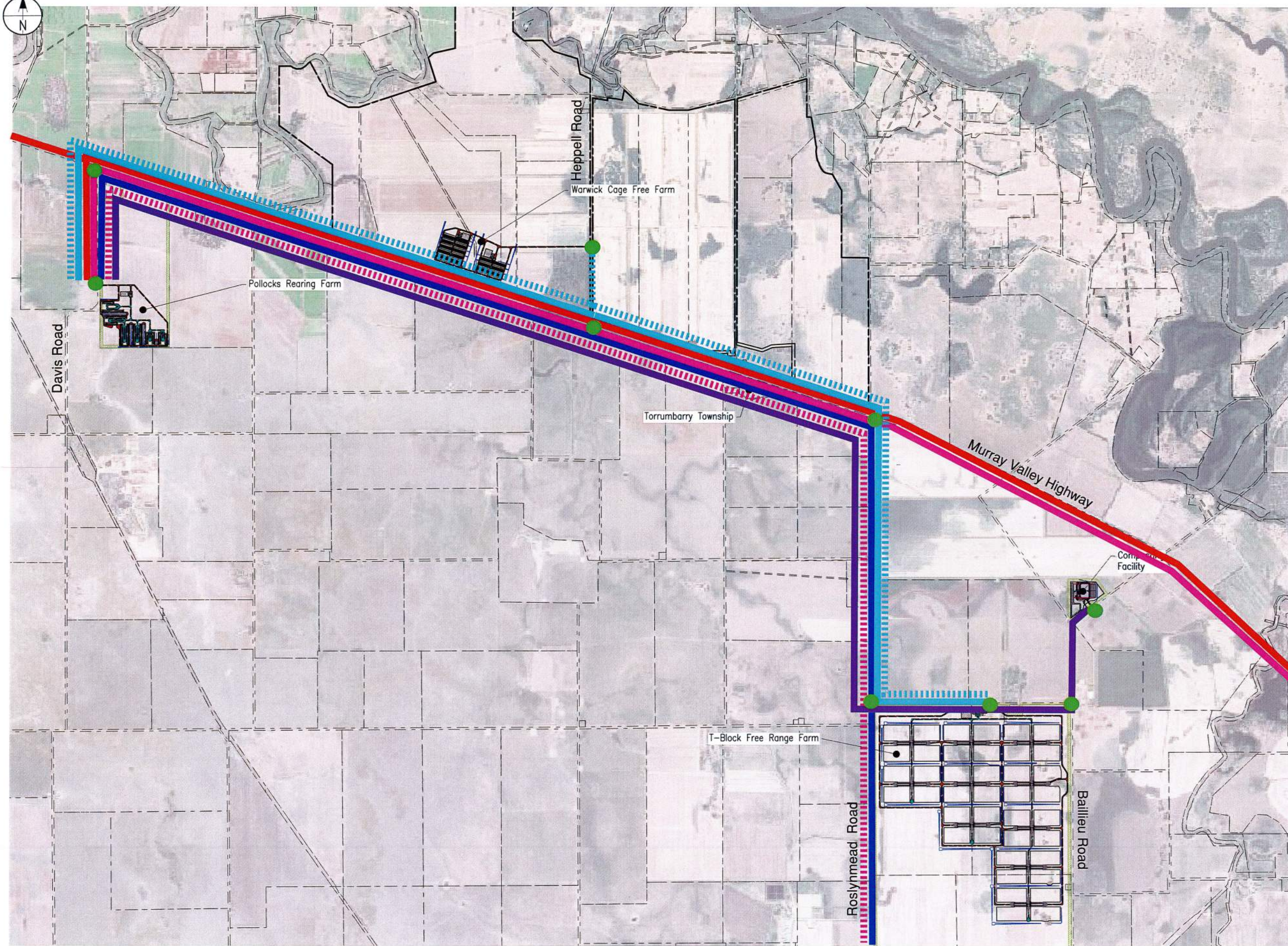

**LEGEND:**  
EXISTING

----- Property Boundary

**PLAN NOTES:**  
 P.1. Plan is intended to be viewed in colour.  
 P.2. Intervals between contours - 0.1m.  
 Contours are design surface levels.  
 P.3.

**DISCLAIMER NOTES:**  
 D.1. This is a sketch plan only and is conceptual only.  
 D.2. This sketch plan represents design intent and concepts only.  
 D.3. Information shown on these plans has been compiled from varying sources and may not be accurate and will need verifying. This includes imagery, existing infrastructure, property boundaries and natural surface data.  
 D.4. No reliance should be placed on the information on this plan for detailed design or any financial dealings involving this land.  
 D.5. This plan shall not be used for tendering, financing, ordering of materials, construction or any other unintended purpose.

- █ Staff Vehicle Movements
- █ Chicks in
- ▤ Pullets out (Warwick's Block)
- ▤ Pullets out (T-Block Block)
- █ Feed Delivery (Route 1)
- ▤ Feed Delivery (Route 2)
- █ Manure
- Key Intersections

## TRAVEL ROUTE MAP - POLLOCK'S BLOCK REARING FARM

Scale 1:20000 (A1)

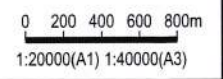

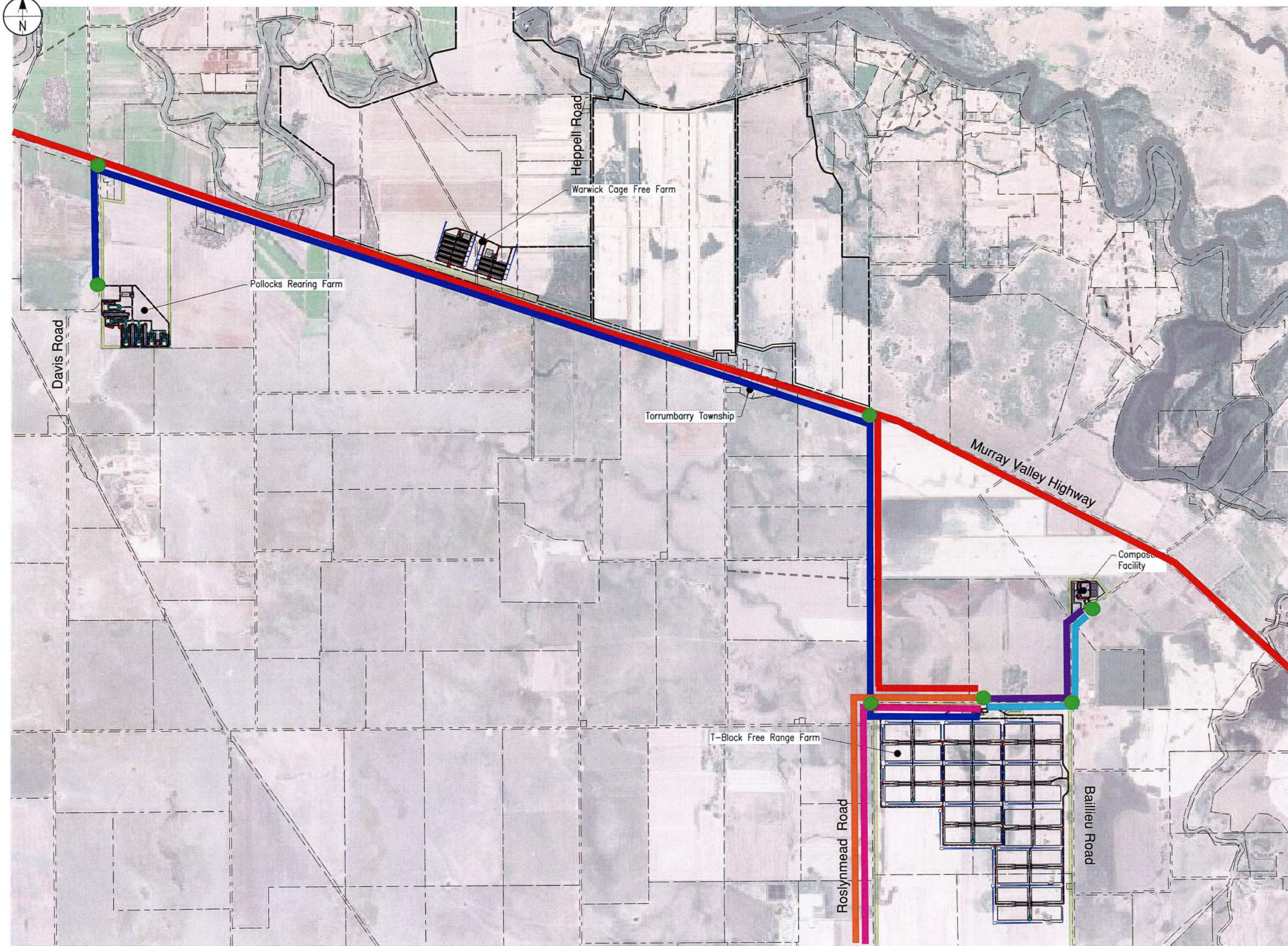

**LEGEND:**  
 EXISTING  
 - - - - - Property Boundary

**PLAN NOTES:**  
 P.1. Plan is intended to be viewed in colour.  
 P.2. Intervals between contours - 0.1m.  
 Contours are design surface levels.  
 P.3.

**DISCLAIMER NOTES:**  
 D.1. This is a sketch plan only and is conceptual only.  
 D.2. This sketch plan represents design intent and concepts only.  
 D.3. Information shown on these plans has been compiled from varying sources and may not be accurate and will need verifying. This includes imagery, existing infrastructure, property boundaries and natural surface data.  
 D.4. No reliance should be placed on the information on this plan for detailed design or any financial dealings involving this land.  
 D.5. This plan shall not be used for tendering, financing, ordering of materials, construction or any other unintended purpose.

- Staff Vehicle Movements
- Pullets in
- Hens out
- Feed Delivery
- Egg Collection
- Manure
- Key Intersections

**TRAVEL ROUTE MAP - T-BLOCK FREE RANGE LAYER FARM**

Scale 1:20000 (A1)

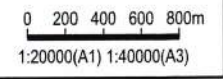

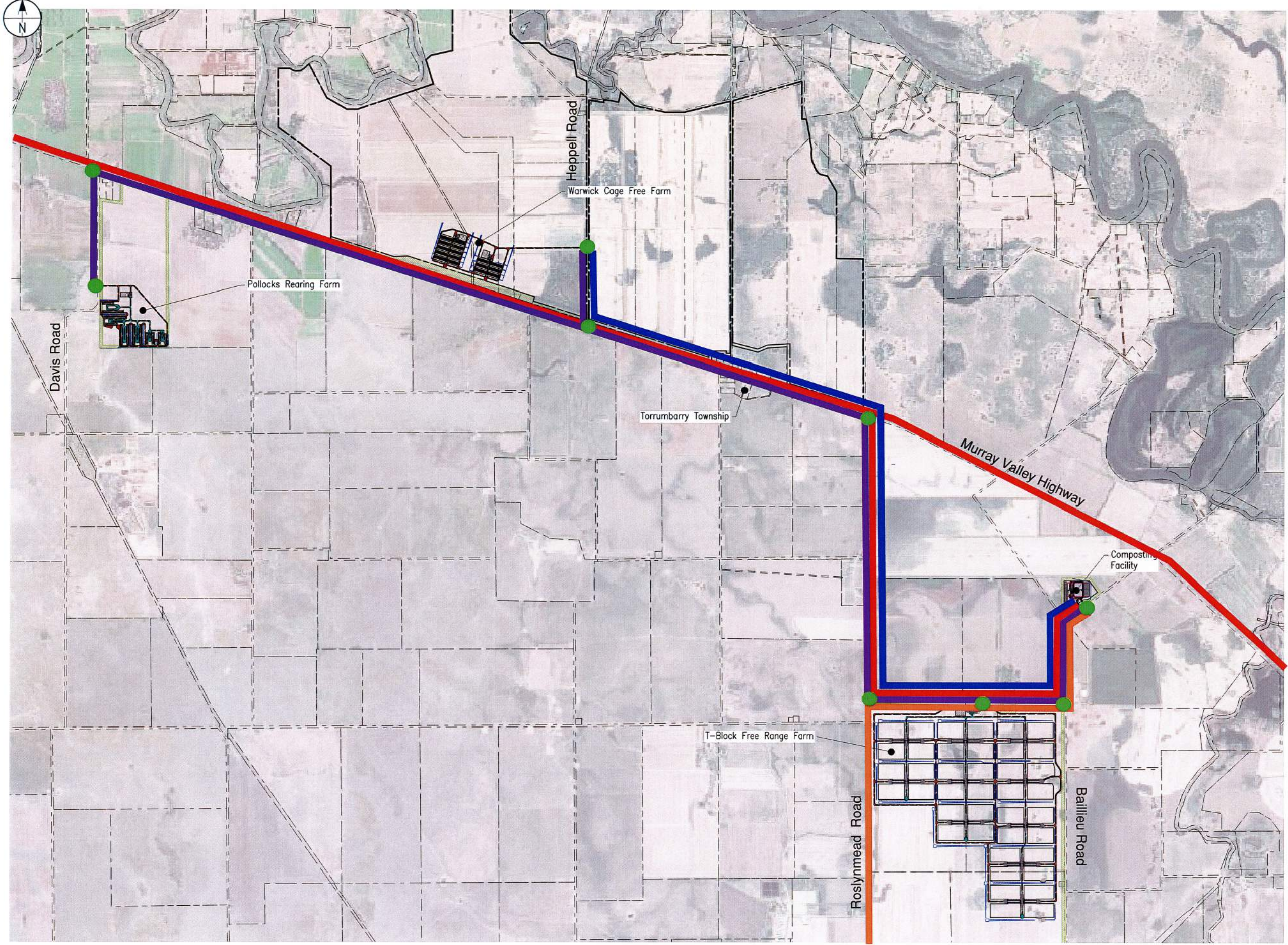

**LEGEND:**  
 EXISTING  
 - - - - - Property Boundary

**PLAN NOTES:**  
 P.1. Plan is intended to be viewed in colour.  
 P.2. Intervals between contours - 0.1m.  
 Contours are design surface levels.  
 P.3.

**DISCLAIMER NOTES:**  
 D.1. This is a sketch plan only and is conceptual only.  
 D.2. This sketch plan represents design intent and concepts only.  
 D.3. Information shown on these plans has been compiled from varying sources and may not be accurate and will need verifying. This includes imagery, existing infrastructure, property boundaries and natural surface data.  
 D.4. No reliance should be placed on the information on this plan for detailed design or any financial dealings involving this land.  
 D.5. This plan shall not be used for tendering, financing, ordering of materials, construction or any other unintended purpose.

- Staff Vehicle Movements
- Composting
- Carbon Source
- Manure
- Key Intersections

## TRAVEL ROUTE MAP - COMPOSTING FACILITY

Scale 1:20000 (A1)

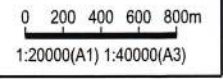

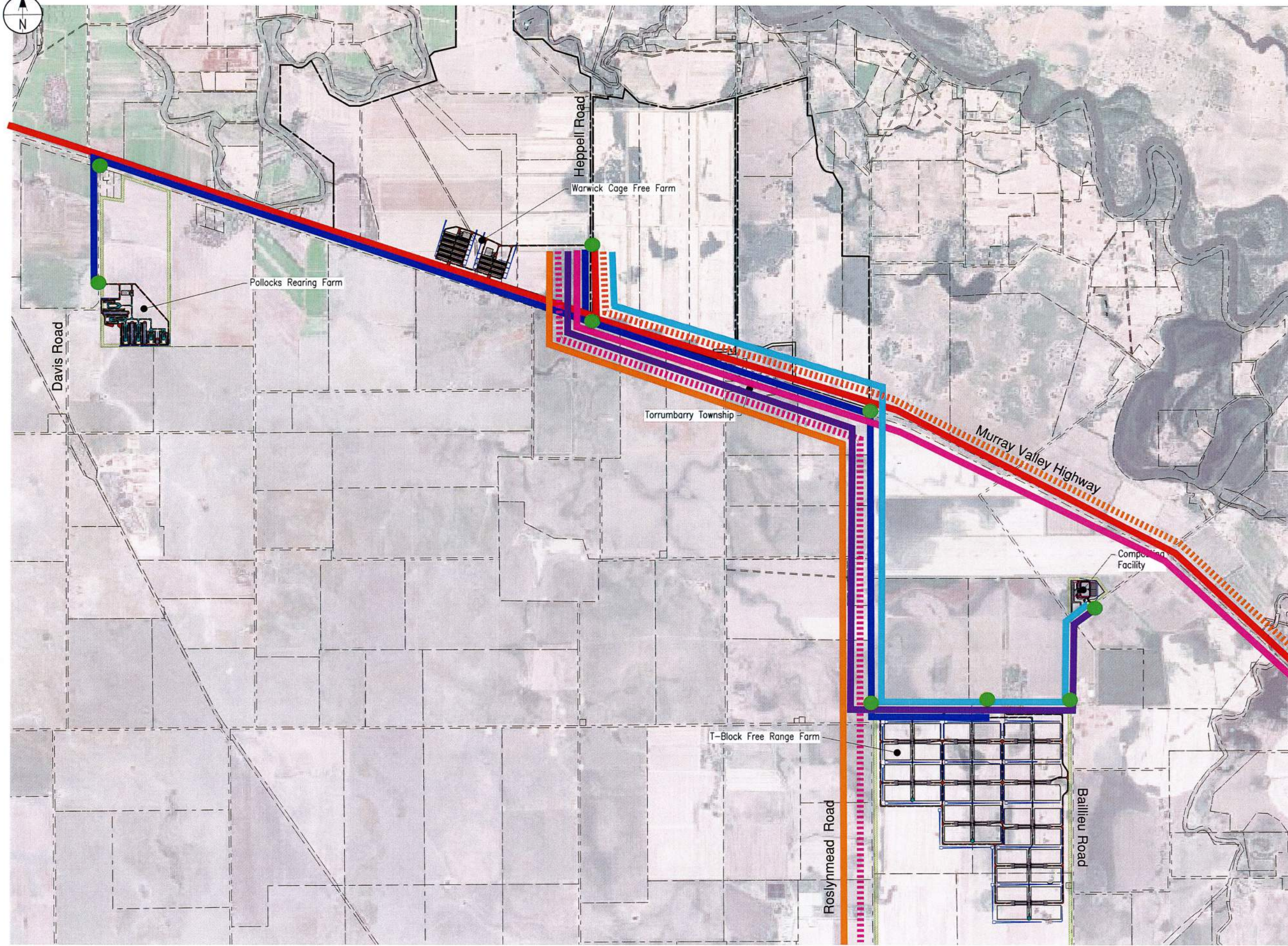

**LEGEND:**  
EXISTING

----- Property Boundary

**PLAN NOTES:**  
P.1. Plan is intended to be viewed in colour.  
P.2. Intervals between contours - 0.1m.  
Contours are design surface levels.  
P.3.

**DISCLAIMER NOTES:**  
D.1. This is a sketch plan only and is conceptual only.  
D.2. This sketch plan represents design intent and concepts only.  
D.3. Information shown on these plans has been compiled from varying sources and may not be accurate and will need verifying. This includes imagery, existing infrastructure, property boundaries and natural surface data.  
D.4. No reliance should be placed on the information on this plan for detailed design or any financial dealings involving this land.  
D.5. This plan shall not be used for tendering, financing, ordering of materials, construction or any other unintended purpose.

- Staff Vehicle Movements
- Pullets in
- Hens out
- Feed Delivery (Route 1)
- ⋯ Feed Delivery (Route 2)
- Egg Collection (Route 1)
- ⋯ Egg Collection (Route 2)
- Manure
- Key Intersections

### TRAVEL ROUTE MAP - WARWICK'S BLOCK CAGE FREE LAYER FARM

Scale 1:20000 (A1)

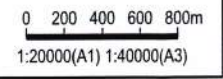

## Appendix C Traffic count data

Client : RMA Engineers  
 Job : Torrumbarry & Patho Intersection Counts  
 Day/Date : Wednesday, 7 May 2025  
 Survey Location : Murray Valley Hwy & Davis Rd  
 Weather : Fine

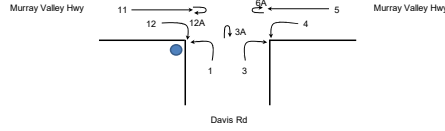

Time Period	Movement 1			Movement 3			Movement 3A			Movement 4			Movement 5			Movement 5A			Movement 11			Movement 12			Movement 12A			Total of all Movements	Peak Hour Volume Determination			
	Light	Heavy	Total	Light	Heavy	Total	Light	Heavy	Total	Light	Heavy	Total	Light	Heavy	Total	Light	Heavy	Total	Light	Heavy	Total	Light	Heavy	Total	Light	Heavy	Total					
3:00 - 3:15	0	0	0	0	0	0	0	0	0	0	0	0	0	1	1	2	0	0	0	0	1	1	2	0	0	0	0	0	0	2	3:00 - 4:00	12
3:15 - 3:30	0	0	0	0	0	0	0	0	0	0	0	0	0	2	2	4	0	0	0	0	1	1	2	0	0	0	0	0	0	3	3:15 - 4:15	12
3:30 - 3:45	0	0	0	0	0	0	0	0	0	0	0	0	1	1	2	0	0	0	0	1	0	1	0	0	0	0	0	0	3	3:30 - 4:30	9	
3:45 - 4:00	0	0	0	0	0	0	0	0	0	0	0	0	3	3	6	0	0	0	0	1	0	1	0	0	0	0	0	0	4	3:45 - 4:45	9	
4:00 - 4:15	0	0	0	0	0	0	0	0	0	0	0	0	1	1	2	0	0	0	0	1	0	1	0	0	0	0	0	0	2	4:00 - 5:00	7	
4:15 - 4:30	0	0	0	0	0	0	0	0	0	0	0	0	0	0	0	0	0	0	0	0	0	0	0	0	0	0	0	0	0	0	4:15 - 5:15	18
4:30 - 4:45	0	0	0	0	0	0	0	0	0	0	0	0	1	0	1	0	0	0	0	2	0	2	0	0	0	0	0	0	3	4:30 - 5:30	26	
4:45 - 5:00	0	0	0	0	0	0	0	0	0	0	0	0	1	1	2	0	0	0	0	1	1	2	0	0	0	0	0	0	2	4:45 - 5:45	32	
5:00 - 5:15	0	0	0	0	0	0	0	0	0	0	1	0	1	1	4	5	0	0	0	7	0	7	0	0	0	0	0	0	13	5:00 - 6:00	41	
5:15 - 5:30	0	0	0	0	0	0	0	0	0	0	0	0	1	2	3	0	0	0	0	3	1	4	0	0	0	0	0	0	7	5:15 - 6:15	43	
5:30 - 5:45	0	0	0	0	0	0	0	0	0	0	1	1	2	3	5	0	0	0	0	3	0	3	1	0	1	0	0	0	10	5:30 - 6:30	73	
5:45 - 6:00	0	0	0	0	0	0	0	0	0	0	1	1	4	0	4	0	0	0	0	6	0	6	0	0	0	0	0	0	11	5:45 - 6:45	88	
6:00 - 6:15	0	0	0	0	0	0	0	0	0	0	0	0	1	5	6	0	0	0	0	6	3	9	0	0	0	0	0	0	15	6:00 - 7:00	108	
6:15 - 6:30	0	0	0	1	0	1	0	0	0	0	1	1	14	4	18	0	0	0	0	13	3	16	1	0	1	0	0	0	37	6:15 - 7:15	127	
6:30 - 6:45	0	0	0	0	0	0	0	0	0	3	3	12	1	13	0	0	0	0	8	1	9	0	0	0	0	0	0	0	25	6:30 - 7:30	149	
6:45 - 7:00	0	1	1	0	1	1	0	0	0	0	0	0	9	8	17	0	0	0	0	10	2	12	0	0	0	0	0	0	31	6:45 - 7:45	176	
7:00 - 7:15	0	0	0	0	0	0	0	0	0	0	0	0	10	6	16	0	0	0	0	17	1	18	0	0	0	0	0	0	34	7:00 - 8:00	207	
7:15 - 7:30	0	0	0	0	4	4	0	0	0	0	0	0	22	7	29	0	0	0	0	21	5	26	0	0	0	0	0	0	59	7:15 - 8:15	224	
7:30 - 7:45	0	0	0	0	0	0	0	0	0	0	0	0	25	4	29	0	0	0	0	21	2	23	0	0	0	0	0	0	52	7:30 - 8:30	232	
7:45 - 8:00	0	0	0	0	0	0	0	0	0	0	0	0	29	5	34	0	0	0	0	23	5	28	0	0	0	0	0	0	62	7:45 - 8:45	229	
8:00 - 8:15	0	0	0	1	0	1	0	0	0	0	1	1	20	10	30	0	0	0	0	16	3	19	0	0	0	0	0	0	51	8:00 - 9:00	221	
8:15 - 8:30	0	0	0	0	0	0	0	0	0	2	2	4	27	8	35	0	0	0	0	25	3	28	0	0	0	0	0	0	67	8:15 - 9:15	224	
8:30 - 8:45	0	0	0	0	0	0	0	0	0	0	0	0	15	9	24	0	0	0	0	19	6	25	0	0	0	0	0	0	49	8:30 - 9:30	217	
8:45 - 9:00	0	0	0	0	1	1	0	0	0	0	2	2	22	4	26	0	0	0	0	24	1	25	0	0	0	0	0	0	54	8:45 - 9:45	238	
9:00 - 9:15	0	0	0	0	1	1	0	0	0	0	2	2	11	6	17	0	0	0	0	33	1	34	0	0	0	0	0	0	54	9:00 - 10:00	236	
9:15 - 9:30	0	0	0	0	1	1	0	0	0	0	0	0	14	4	18	0	0	0	0	34	6	40	1	0	1	0	0	0	60	9:15 - 10:15	227	
9:30 - 9:45	1	0	1	0	1	1	0	0	0	0	1	1	27	6	33	0	0	0	0	32	2	34	0	0	0	0	0	0	70	9:30 - 10:30	227	
9:45 - 10:00	0	0	0	0	0	0	0	0	0	0	0	0	17	7	24	0	0	0	0	25	3	28	0	0	0	0	0	0	52	9:45 - 10:45	214	
10:00 - 10:15	0	1	1	0	1	1	0	0	0	0	0	0	18	4	22	0	0	0	0	17	4	21	0	0	0	0	0	0	45	10:00 - 11:00	219	
10:15 - 10:30	0	0	0	1	2	3	0	0	0	0	1	1	15	5	20	0	0	0	0	33	3	36	0	0	0	0	0	0	60	10:15 - 11:15	219	
10:30 - 10:45	0	0	0	0	0	0	0	0	0	0	0	0	19	8	27	0	0	0	0	26	3	29	0	1	1	0	0	0	57	10:30 - 11:30	222	
10:45 - 11:00	0	1	1	0	0	0	0	0	0	0	0	0	22	5	27	0	0	0	0	25	4	29	0	0	0	0	0	0	57	10:45 - 11:45	220	
11:00 - 11:15	0	0	0	0	0	0	0	0	0	0	1	1	16	1	17	0	0	0	0	22	4	26	0	1	1	0	0	0	45	11:00 - 12:00	217	
11:15 - 11:30	0	0	0	0	1	1	0	0	0	0	2	2	31	4	35	0	0	0	0	18	6	24	0	1	1	0	0	0	63	11:15 - 12:15	210	
11:30 - 11:45	0	1	1	0	1	1	0	0	0	0	0	0	24	4	28	0	0	0	0	19	6	25	0	0	0	0	0	0	55	11:30 - 12:30	206	
11:45 - 12:00	0	0	0	0	0	0	0	0	0	0	2	2	16	4	20	0	0	0	0	25	7	32	0	0	0	0	0	0	54	11:45 - 12:45	200	
12:00 - 12:15	0	1	1	0	1	1	0	0	0	0	1	1	12	1	13	0	0	0	0	11	11	22	0	0	0	0	0	0	38	12:00 - 13:00	189	
12:15 - 12:30	1	1	2	0	0	0	0	0	0	0	1	1	22	5	27	0	0	0	0	20	8	28	0	1	1	0	0	0	59	12:15 - 13:15	214	
12:30 - 12:45	0	0	0	0	3	3	0	0	0	0	0	0	18	3	21	0	0	0	0	19	5	24	0	0	0	1	0	1	49	12:30 - 13:30	199	
12:45 - 13:00	0	0	0	0	0	0	0	0	0	0	0	0	19	1	20	0	0	0	0	15	8	23	0	0	0	0	0	0	43	12:45 - 13:45	195	
13:00 - 13:15	0	1	1	1	1	2	0	0	0	0	2	2	22	3	25	0	0	0	0	23	10	33	0	0	0	0	0	0	63	13:00 - 14:00	211	
13:15 - 13:30	0	0	0	0	0	0	0	0	0	1	1	2	10	4	14	0	0	0	0	20	7	27	0	1	1	0	0	0	44	13:15 - 14:15	204	
13:30 - 13:45	0	2	2	0	0	0	0	0	0	0	2	2	16	1	17	0	0	0	0	16	8	24	0	0	0	0	0	0	45	13:30 - 14:30	230	
13:45 - 14:00	0	0	0	0	1	1	0	0	0	0	1	1	29	2	31	0	0	0	0	22	4	26	0	0	0	0	0	0	59	13:45 - 14:45	226	
14:00 - 14:15	0	0	0	0	3	3	0	0	0	0	0	0	25	5	30	0	0	0	0	16	7	23	0	0	0	0	0	0	56	14:00 - 15:00	223	
14:15 - 14:30	0	0	0	0	0	0	0	0	0	0	1	1	29	3	32	0	0	0	0	28	9	37	0	0	0	0	0	0	70	14:15 - 15:15	219	
14:30 - 14:45	0	0	0	0	1	1	0	0	0	0	1	1	12	1	13	0	0	0	0	23	3	26	0	0	0	0	0	0	41	14:30 - 15:30	201	
14:45 - 15:00	0	0	0	0	0	0	0	0	0	0	0	0	24	3	27	0	0	0	0	26	3	29	0	0	0	0	0	0	56	14:45 - 15:45	214	
15:00 - 15:15	0	0	0	1	0	1	0	0	0	0	1	1	23	2	25	0	0	0	0	22	3	25	0	0	0	0	0	0	52	15:00 - 16:00	229	
15:15 - 15:30	0	0	0	0	2	2	0	0	0	0	0	0	24	1	25	0	0	0	0	18	7	25	0	0	0	0	0	0	52	15:15 - 16:15	242	
15:30 - 15:45	0	0	0	0	1	1	0	0	0	0	0	0	27	3	30	0	0	0	0	21	2	23	0	0	0	0	0	0	54	15:30 - 16:30	239	
15:45 - 16:00	0	0	0	2	0	2	0	0	0	0	0	0	38	6	44	0	0	0	0	19	6	25	0	0	0	0	0	0	71	15:45 - 16:45	248	
16:00 - 16:15	2	0	2																													

Client : RMA Engineers  
 Job : Torrumbarry & Patho Intersection Counts  
 Day/Date : Wednesday, 7 May 2025  
 Survey Location : Murray Valley Hwy & Davis Rd  
 Weather : Fine

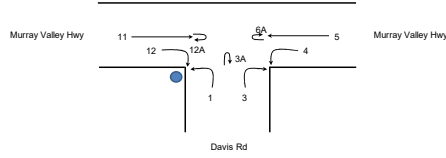

18:30 - 18:45	0	0	0	0	0	0	0	0	0	0	0	0	0	14	2	16	0	0	0	0	7	4	11	0	0	0	0	0	0	0	0	0	0	0	27	18:30 - 19:30	67
18:45 - 19:00	0	0	0	0	0	0	0	0	0	0	0	0	0	8	3	11	0	0	0	0	3	1	4	0	0	0	0	0	0	0	0	0	0	0	15	18:45 - 19:45	53
19:00 - 19:15	0	0	0	0	0	0	0	0	0	0	0	0	0	9	3	12	0	0	0	0	2	0	2	0	0	0	0	0	0	0	0	0	0	14	19:00 - 20:00	51	
19:15 - 19:30	0	0	0	0	0	0	0	0	0	0	0	0	0	4	1	5	0	0	0	0	3	3	6	0	0	0	0	0	0	0	0	0	0	11	19:15 - 20:15	46	
19:30 - 19:45	0	0	0	0	0	0	0	0	0	0	0	0	1	3	3	6	0	0	0	0	5	1	6	0	0	0	0	0	0	0	0	0	13	19:30 - 20:30	44		
19:45 - 20:00	0	0	0	1	0	1	0	0	0	0	0	0	0	5	2	7	0	0	0	0	3	2	5	0	0	0	0	0	0	0	0	0	13	19:45 - 20:45	43		
20:00 - 20:15	0	0	0	0	0	0	0	0	0	0	0	0	0	5	1	6	0	0	0	0	3	0	3	0	0	0	0	0	0	0	0	0	9	20:00 - 21:00	45		
20:15 - 20:30	0	0	0	0	0	0	0	0	0	0	0	0	0	7	0	7	0	0	0	0	1	1	2	0	0	0	0	0	0	0	0	0	9	AM Peak	238		
20:30 - 20:45	0	0	0	0	0	0	0	0	0	0	0	0	0	3	7	10	0	0	0	0	2	0	2	0	0	0	0	0	0	0	0	0	12	PM Peak	248		
20:45 - 21:00	0	0	0	0	0	0	0	0	0	0	0	0	0	6	2	8	0	0	0	0	4	3	7	0	0	0	0	0	0	0	0	0	15				
<b>Total</b>	<b>5</b>	<b>9</b>	<b>14</b>	<b>10</b>	<b>27</b>	<b>37</b>	<b>0</b>	<b>0</b>	<b>0</b>	<b>0</b>	<b>8</b>	<b>31</b>	<b>39</b>	<b>1063</b>	<b>241</b>	<b>1304</b>	<b>0</b>	<b>0</b>	<b>0</b>	<b>1056</b>	<b>248</b>	<b>1334</b>	<b>4</b>	<b>5</b>	<b>9</b>	<b>1</b>	<b>0</b>	<b>1</b>	<b>0</b>	<b>0</b>	<b>1</b>	<b>2738</b>					
<b>AM Peak</b>	<b>1</b>	<b>0</b>	<b>1</b>	<b>0</b>	<b>4</b>	<b>4</b>	<b>0</b>	<b>0</b>	<b>0</b>	<b>0</b>	<b>5</b>	<b>5</b>	<b>74</b>	<b>20</b>	<b>94</b>	<b>0</b>	<b>0</b>	<b>0</b>	<b>0</b>	<b>123</b>	<b>10</b>	<b>133</b>	<b>1</b>	<b>0</b>	<b>1</b>	<b>0</b>	<b>0</b>	<b>0</b>	<b>0</b>	<b>0</b>	<b>0</b>	<b>238</b>					
<b>PM Peak</b>	<b>2</b>	<b>0</b>	<b>2</b>	<b>2</b>	<b>0</b>	<b>2</b>	<b>0</b>	<b>0</b>	<b>0</b>	<b>0</b>	<b>0</b>	<b>0</b>	<b>110</b>	<b>17</b>	<b>127</b>	<b>0</b>	<b>0</b>	<b>0</b>	<b>0</b>	<b>97</b>	<b>20</b>	<b>117</b>	<b>0</b>	<b>0</b>	<b>0</b>	<b>0</b>	<b>0</b>	<b>0</b>	<b>0</b>	<b>0</b>	<b>0</b>	<b>248</b>					

Client : RMA Engineers  
 Job : Torrumbarry & Patho Intersection Counts  
 Day/Date : Wednesday, 7 May 2025  
 Survey Location : Murray Valley Hwy & Davis Rd  
 Weather : Fine

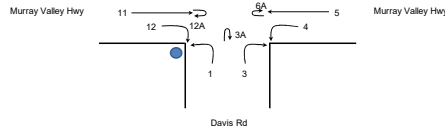

HOURLY FLOW

TIME PERIOD	Movement 1			Movement 3			Movement 3A			Movement 4			Movement 5			Movement 6A			Movement 11			Movement 12			Movement 12A			Grand Total				
	Light	Heavy	Total	Light	Heavy	Total	Light	Heavy	Total	Light	Heavy	Total	Light	Heavy	Total	Light	Heavy	Total	Light	Heavy	Total	Light	Heavy	Total	Light	Heavy	Total	Light	Heavy	Total	Light	Heavy
3:00 - 4:00	0	0	0	0	0	0	0	0	0	0	0	0	1	7	8	0	0	0	2	2	4	0	0	0	0	0	0	0	3	9	12	
3:15 - 4:15	0	0	0	0	0	0	0	0	0	0	0	0	1	7	8	0	0	0	3	1	4	0	0	0	0	0	0	0	4	8	12	
3:30 - 4:30	0	0	0	0	0	0	0	0	0	0	0	0	1	5	6	0	0	0	3	0	3	0	0	0	0	0	0	0	4	5	9	
3:45 - 4:45	0	0	0	0	0	0	0	0	0	0	0	0	1	4	5	0	0	0	4	0	4	0	0	0	0	0	0	0	5	4	9	
4:00 - 5:00	0	0	0	0	0	0	0	0	0	0	0	0	1	2	3	0	0	0	3	1	4	0	0	0	0	0	0	4	3	7		
4:15 - 5:15	0	0	0	0	0	0	0	0	0	0	0	1	2	5	7	0	0	0	9	1	10	0	0	0	0	0	0	12	6	18		
4:30 - 5:30	0	0	0	0	0	0	0	0	0	0	1	0	1	3	7	10	0	0	0	12	2	14	0	0	0	0	0	16	9	25		
4:45 - 5:45	0	0	0	0	0	0	0	0	1	1	2	4	10	14	0	0	0	13	2	15	1	0	1	0	0	0	19	13	32			
5:00 - 6:00	0	0	0	0	0	0	0	0	1	2	3	8	9	17	0	0	0	19	1	20	1	0	1	0	0	0	29	12	41			
5:15 - 6:15	0	0	0	0	0	0	0	0	0	2	2	8	10	18	0	0	0	18	4	22	1	0	1	0	0	0	27	16	43			
5:30 - 6:30	0	0	0	1	0	1	0	0	0	3	3	21	12	33	0	0	0	28	6	34	2	0	2	0	0	0	52	21	73			
5:45 - 6:45	0	0	0	1	0	1	0	0	0	5	5	31	10	41	0	0	0	33	7	40	1	0	1	0	0	0	66	22	88			
6:00 - 7:00	0	1	1	1	1	2	0	0	0	4	4	36	18	54	0	0	0	37	9	46	1	0	1	0	0	0	75	33	108			
6:15 - 7:15	0	1	1	1	1	2	0	0	0	4	4	45	19	64	0	0	0	48	7	55	1	0	1	0	0	0	95	32	127			
6:30 - 7:30	0	1	1	0	5	5	0	0	0	3	3	53	22	75	0	0	0	56	9	65	0	0	0	0	0	0	109	40	149			
6:45 - 7:45	0	1	1	0	5	5	0	0	0	0	0	66	25	91	0	0	0	69	10	79	0	0	0	0	0	0	135	41	176			
7:00 - 8:00	0	0	0	0	4	4	0	0	0	0	0	86	22	108	0	0	0	82	13	95	0	0	0	0	0	0	168	39	207			
7:15 - 8:15	0	0	0	1	4	5	0	0	0	1	1	96	28	122	0	0	0	81	15	96	0	0	0	0	0	0	178	46	224			
7:30 - 8:30	0	0	0	1	0	1	0	0	0	2	3	5	101	27	128	0	0	0	85	13	98	0	0	0	0	0	189	43	232			
7:45 - 8:45	0	0	0	1	0	1	0	0	0	2	3	5	91	32	123	0	0	0	83	17	100	0	0	0	0	0	177	52	229			
8:00 - 9:00	0	0	0	1	1	2	0	0	0	2	5	7	84	31	115	0	0	0	84	13	97	0	0	0	0	0	171	50	221			
8:15 - 9:15	0	0	0	0	2	2	0	0	0	2	6	8	75	27	102	0	0	0	101	11	112	0	0	0	0	0	178	46	224			
8:30 - 9:30	0	0	0	0	3	3	0	0	0	0	4	4	62	23	85	0	0	0	110	14	124	1	0	1	0	0	173	44	217			
8:45 - 9:45	1	0	1	0	4	4	0	0	0	5	5	74	20	94	0	0	0	123	10	133	1	0	1	0	0	0	199	39	238			
9:00 - 10:00	1	0	1	0	3	3	0	0	0	0	3	3	69	23	92	0	0	0	124	12	136	1	0	1	0	0	195	41	236			
9:15 - 10:15	1	1	2	0	3	3	0	0	0	0	1	1	76	21	97	0	0	0	108	15	123	1	0	1	0	0	186	41	227			
9:30 - 10:30	1	1	2	1	4	5	0	0	0	0	2	2	77	22	99	0	0	0	107	12	119	0	0	0	0	0	188	41	227			
9:45 - 10:45	0	1	1	1	3	4	0	0	0	0	1	1	69	24	93	0	0	0	101	13	114	0	1	1	0	0	171	43	214			
10:00 - 11:00	0	2	2	1	3	4	0	0	0	0	1	1	74	22	96	0	0	0	101	14	115	0	1	1	0	0	176	43	219			
10:15 - 11:15	0	1	1	1	2	3	0	0	0	0	2	2	72	19	91	0	0	0	106	14	120	0	2	2	0	0	179	40	219			
10:30 - 11:30	0	1	1	0	1	1	0	0	0	0	3	3	88	18	106	0	0	0	91	17	108	0	3	3	0	0	179	43	222			
10:45 - 11:45	0	2	2	0	2	2	0	0	0	0	3	3	93	14	107	0	0	0	84	20	104	0	2	2	0	0	177	43	220			
11:00 - 12:00	0	1	1	0	2	2	0	0	0	0	5	5	87	13	100	0	0	0	84	23	107	0	2	2	0	0	171	46	217			
11:15 - 12:15	0	2	2	0	3	3	0	0	0	0	5	5	83	13	96	0	0	0	73	30	103	0	1	1	0	0	156	54	210			
11:30 - 12:30	1	3	4	0	2	2	0	0	0	0	4	4	74	14	88	0	0	0	75	32	107	0	1	1	0	0	150	56	206			
11:45 - 12:45	1	2	3	0	4	4	0	0	0	0	4	4	68	13	81	0	0	0	75	31	106	0	1	1	1	0	145	55	200			
12:00 - 13:00	1	2	3	0	4	4	0	0	0	0	2	2	71	10	81	0	0	0	65	32	97	0	1	1	1	0	138	51	189			
12:15 - 13:15	1	2	3	1	4	5	0	0	0	0	3	3	81	12	93	0	0	0	77	31	108	0	1	1	1	0	161	53	214			
12:30 - 13:30	0	1	1	1	4	5	0	0	0	1	3	4	69	11	80	0	0	0	77	30	107	0	1	1	1	0	149	50	199			
12:45 - 13:45	0	3	3	1	1	2	0	0	0	1	5	6	67	9	76	0	0	0	74	33	107	0	1	1	0	0	143	52	195			
13:00 - 14:00	0	3	3	1	2	3	0	0	0	1	6	7	77	10	87	0	0	0	81	29	110	0	1	1	0	0	160	51	211			
13:15 - 14:15	0	2	2	0	4	4	0	0	0	1	4	5	80	12	92	0	0	0	74	26	100	0	1	1	0	0	155	49	204			
13:30 - 14:30	0	2	2	0	4	4	0	0	0	0	4	4	99	11	110	0	0	0	82	28	110	0	0	0	0	0	181	49	230			
13:45 - 14:45	0	0	0	0	5	5	0	0	0	0	3	3	95	11	106	0	0	0	89	23	112	0	0	0	0	0	184	42	226			
14:00 - 15:00	0	0	0	0	4	4	0	0	0	0	2	2	90	12	102	0	0	0	93	22	115	0	0	0	0	0	183	40	223			
14:15 - 15:15	0	0	0	1	1	2	0	0	0	0	3	3	88	9	97	0	0	0	99	18	117	0	0	0	0	0	188	31	219			
14:30 - 15:30	0	0	0	1	3	4	0	0	0	0	2	2	83	7	90	0	0	0	89	16	105	0	0	0	0	0	173	28	201			
14:45 - 15:45	0	0	0	1	3	4	0	0	0	0	1	1	98	9	107	0	0	0	87	15	102	0	0	0	0	0	186	28	214			
15:00 - 16:00	0	0	0	3	3	6	0	0	0	0	1	1	112	12	124	0	0	0	80	18	98	0	0	0	0	0	195	34	229			
15:15 - 16:15	2	0	2	2	3	5	0	0	0	0	0	0	116	15	131	0	0	0	85	19	104	0	0	0	0	0	205	37	242			
15:30 - 16:30	2	0	2	2	1	3	0	0	0	0	0	0	110	18	128	0	0	0	89	17	106	0	0	0	0	0	203	36	239			
15:45 - 16:45	2	0	2	2	0	2	0	0	0	0	0	0	110	17	127	0	0	0	97	20	117	0	0	0	0	0	211	37	248			
16:00 - 17:00	2	0	2	0	0	0	0	0	0	0	0	0	91	12	103	0	0	0	98	18	116	0	0	0	0	0	191	30	221			
16:15 - 17:15	0	0	0	0	0	0	0	0	0	0	0	1	93	7	100	0	0	0	87	18	105	0	0	0	0	0	181	25	206			
16:30 - 17:30	0	0	0	0	0	0	0	0	0	1	0	1	89	9	98	0	0	0	86	14	100	0	0	0	0	0	176	23	199			
16:45 - 17:45	0	0	0	0	0	0	0	0	0	2	0	2	81	11	92	0	0	0	70	13	83	0	0	0	0	0	153	24	177			
17:00 - 18:00</																																

Client : RMA Engineers  
 Job : Torrumberry & Patho Intersection Counts  
 Day/Date : Wednesday, 7 May 2025  
 Survey Location : Murray Valley Hwy & Davis Rd  
 Weather : Fine

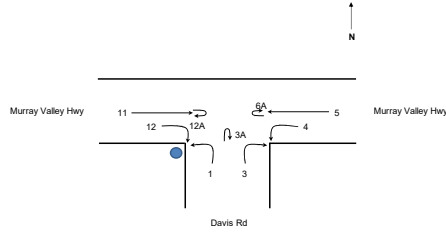

18:45 - 19:45	0	0	0	0	0	0	0	0	0	0	1	0	1	24	10	34	0	0	0	0	13	5	18	0	0	0	0	0	0	0	38	15	53
19:00 - 20:00	0	0	0	1	0	1	0	0	0	0	1	0	1	21	9	30	0	0	0	0	13	6	19	0	0	0	0	0	0	0	36	15	51
19:15 - 20:15	0	0	0	1	0	1	0	0	0	0	1	0	1	17	7	24	0	0	0	0	14	6	20	0	0	0	0	0	0	33	13	46	
19:30 - 20:30	0	0	0	1	0	1	0	0	0	0	1	0	1	20	6	26	0	0	0	0	12	4	16	0	0	0	0	0	0	34	10	44	
19:45 - 20:45	0	0	0	1	0	1	0	0	0	0	0	0	0	20	10	30	0	0	0	0	9	3	12	0	0	0	0	0	0	30	13	43	
20:00 - 21:00	0	0	0	0	0	0	0	0	0	0	0	0	0	21	10	31	0	0	0	0	10	4	14	0	0	0	0	0	0	31	14	45	

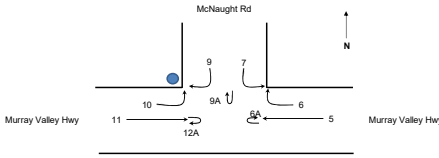

Client : RMA Engineers  
 Job : Torrumbarry & Patho Intersection Counts  
 Day/Date : Wednesday, 7 May 2025  
 Survey Location : Murray Valley Hwy & McNaught Rd  
 Weather : Fine

Time Period	Movement 5			Movement 6			Movement 6A			Movement 7			Movement 9			Movement 9A			Movement 10			Movement 11			Movement 12A			Total of all Movements	Peak Hour Volume Determination	
	Light	Heavy	Total	Light	Heavy	Total	Light	Heavy	Total	Light	Heavy	Total	Light	Heavy	Total	Light	Heavy	Total	Light	Heavy	Total	Light	Heavy	Total	Light	Heavy	Total			
3:00 - 3:15	0	1	1	0	0	0	0	0	0	0	0	0	0	0	0	0	0	0	0	0	0	1	1	2	0	0	0	2	3:00 - 4:00	12
3:15 - 3:30	0	2	2	0	0	0	0	0	0	0	0	0	0	0	0	0	0	0	0	0	0	1	1	2	0	0	0	4	3:15 - 4:15	12
3:30 - 3:45	1	1	2	0	0	0	0	0	0	0	0	0	0	0	0	0	0	0	0	0	0	0	0	0	0	0	0	2	3:30 - 4:30	8
3:45 - 4:00	0	3	3	0	0	0	0	0	0	0	0	0	0	0	0	0	0	0	0	0	0	1	0	1	0	0	0	4	3:45 - 4:45	9
4:00 - 4:15	0	1	1	0	0	0	0	0	0	0	0	0	0	0	0	0	0	0	0	0	0	1	0	1	0	0	0	2	4:00 - 5:00	7
4:15 - 4:30	0	0	0	0	0	0	0	0	0	0	0	0	0	0	0	0	0	0	0	0	0	0	0	0	0	0	0	0	4:15 - 5:15	17
4:30 - 4:45	1	0	1	0	0	0	0	0	0	0	0	0	0	0	0	0	0	0	0	0	0	2	0	2	0	0	0	3	4:30 - 5:30	26
4:45 - 5:00	0	1	1	0	0	0	0	0	0	0	0	0	0	0	0	0	0	0	0	0	0	0	1	1	0	0	0	2	4:45 - 5:45	32
5:00 - 5:15	1	4	5	0	0	0	0	0	0	0	0	0	0	0	0	0	0	0	0	0	7	0	7	0	0	0	12	5:00 - 6:00	40	
5:15 - 5:30	1	2	3	0	0	0	0	0	0	0	0	0	0	0	0	0	0	0	0	1	0	1	3	1	4	0	0	8	5:15 - 6:15	43
5:30 - 5:45	2	3	5	0	0	0	0	0	0	0	0	0	0	0	0	0	0	0	1	0	1	4	0	4	0	0	10	5:30 - 6:30	69	
5:45 - 6:00	4	0	4	0	0	0	0	0	0	0	0	0	0	0	0	0	0	0	0	0	6	0	6	0	0	0	10	5:45 - 6:45	82	
6:00 - 6:15	1	5	6	0	0	0	0	0	0	0	0	0	0	0	0	0	0	0	0	0	6	3	9	0	0	0	15	6:00 - 7:00	102	
6:15 - 6:30	14	4	18	0	0	0	0	0	0	0	0	0	0	0	0	0	0	0	0	0	13	3	16	0	0	0	34	6:15 - 7:15	121	
6:30 - 6:45	12	1	13	0	0	0	0	0	0	0	0	0	0	0	0	0	0	0	1	0	1	8	1	9	0	0	23	6:30 - 7:30	142	
6:45 - 7:00	9	9	18	0	0	0	0	0	0	0	0	0	0	0	0	0	0	0	0	0	10	2	12	0	0	0	30	6:45 - 7:45	172	
7:00 - 7:15	9	6	15	1	0	1	0	0	0	0	0	0	0	0	0	0	0	0	0	0	17	1	18	0	0	0	34	7:00 - 8:00	204	
7:15 - 7:30	22	7	29	0	0	0	0	0	0	0	0	0	0	0	0	0	0	0	0	0	21	5	26	0	0	0	55	7:15 - 8:15	219	
7:30 - 7:45	26	4	30	0	0	0	0	0	0	0	0	0	0	0	0	0	0	0	0	0	21	2	23	0	0	0	53	7:30 - 8:30	228	
7:45 - 8:00	29	5	34	0	0	0	0	0	0	0	0	0	0	0	0	0	0	0	0	0	23	5	28	0	0	0	62	7:45 - 8:45	223	
8:00 - 8:15	20	10	30	0	0	0	0	0	0	0	0	0	0	0	0	0	0	0	0	0	16	3	19	0	0	0	49	8:00 - 9:00	213	
8:15 - 8:30	26	8	34	0	0	0	0	0	0	0	0	0	0	0	0	0	0	0	1	0	1	26	3	29	0	0	64	8:15 - 9:15	215	
8:30 - 8:45	15	8	23	0	0	0	0	0	0	2	0	2	0	0	0	0	0	0	0	0	17	6	23	0	0	0	48	8:30 - 9:30	212	
8:45 - 9:00	23	5	28	0	0	0	0	0	0	0	0	0	0	0	0	0	0	0	0	0	23	1	24	0	0	0	52	8:45 - 9:45	230	
9:00 - 9:15	11	5	16	0	1	1	0	0	0	0	0	0	0	0	0	0	0	0	0	0	33	1	34	0	0	0	51	9:00 - 10:00	230	
9:15 - 9:30	14	4	18	0	0	0	0	0	0	0	0	0	1	0	1	0	0	0	0	0	35	7	42	0	0	0	61	9:15 - 10:15	223	
9:30 - 9:45	27	6	33	0	0	0	0	0	0	0	0	0	0	0	0	0	0	0	0	0	32	1	33	0	0	0	66	9:30 - 10:30	219	
9:45 - 10:00	17	7	24	0	0	0	1	0	1	0	0	0	0	0	0	0	0	0	0	0	24	3	27	0	0	0	52	9:45 - 10:45	211	
10:00 - 10:15	18	5	23	0	0	0	0	0	0	0	0	0	0	0	0	0	0	0	0	0	17	4	21	0	0	0	44	10:00 - 11:00	216	
10:15 - 10:30	15	5	20	0	0	0	0	0	0	1	0	1	0	0	0	0	0	0	0	1	0	1	32	3	35	0	0	57	10:15 - 11:15	217
10:30 - 10:45	19	8	27	0	0	0	0	0	0	0	0	0	0	1	1	0	0	0	0	0	26	4	30	0	0	0	58	10:30 - 11:30	223	
10:45 - 11:00	22	6	28	0	0	0	0	0	0	0	0	0	0	0	0	0	0	0	0	0	25	4	29	0	0	0	57	10:45 - 11:45	221	
11:00 - 11:15	15	1	16	1	0	1	0	0	0	0	0	0	0	0	0	0	0	0	0	1	1	22	5	27	0	0	45	11:00 - 12:00	218	
11:15 - 11:30	31	4	35	0	0	0	0	0	0	0	0	0	1	1	2	0	0	0	0	1	0	1	18	7	25	0	0	63	11:15 - 12:15	210
11:30 - 11:45	23	5	28	0	0	0	0	0	0	0	0	0	2	0	2	0	0	0	0	1	1	19	6	25	0	0	56	11:30 - 12:30	208	
11:45 - 12:00	17	4	21	0	0	0	0	0	0	1	0	1	0	1	1	0	0	0	0	0	24	7	31	0	0	0	54	11:45 - 12:45	196	
12:00 - 12:15	12	2	14	0	0	0	0	0	0	0	1	1	0	0	0	0	0	0	1	0	1	11	10	21	0	0	37	12:00 - 13:00	185	
12:15 - 12:30	23	6	29	0	0	0	0	0	0	0	0	0	0	0	0	0	0	0	1	0	1	22	9	31	0	0	61	12:15 - 13:15	207	
12:30 - 12:45	18	3	21	0	0	0	0	0	0	0	0	0	0	0	0	0	0	0	0	0	18	5	23	0	0	0	44	12:30 - 13:30	191	
12:45 - 13:00	18	1	19	1	0	1	0	0	0	0	0	0	0	0	0	0	0	0	0	0	15	8	23	0	0	0	43	12:45 - 13:45	188	
13:00 - 13:15	22	4	26	0	0	0	0	0	0	1	0	1	0	0	0	0	0	0	0	0	22	10	32	0	0	0	59	13:00 - 14:00	204	
13:15 - 13:30	9	4	13	0	0	0	0	0	0	0	0	0	0	0	0	0	0	0	1	0	1	22	9	31	0	0	45	13:15 - 14:15	200	
13:30 - 13:45	15	3	18	1	0	1	0	0	0	0	0	0	0	0	0	0	0	0	0	0	15	7	22	0	0	0	41	13:30 - 14:30	224	
13:45 - 14:00	30	2	32	0	0	0	0	0	0	1	0	1	1	0	1	0	0	0	0	0	21	4	25	0	0	0	59	13:45 - 14:45	223	
14:00 - 14:15	26	5	31	0	0	0	0	0	0	0	0	0	0	0	0	0	0	0	1	1	16	7	23	0	0	0	55	14:00 - 15:00	220	
14:15 - 14:30	29	3	32	0	0	0	0	0	0	0	0	0	0	0	0	0	0	0	0	0	28	9	37	0	0	0	69	14:15 - 15:15	214	
14:30 - 14:45	12	1	13	0	0	0	0	0	0	0	0	0	1	0	1	0	0	0	0	0	23	3	26	0	0	0	40	14:30 - 15:30	197	
14:45 - 15:00	24	3	27	0	0	0	0	0	0	0	0	0	0	0	0	0	0	0	0	0	26	3	29	0	0	0	56	14:45 - 15:45	210	
15:00 - 15:15	22	2	24	0	0	0	0	0	0	0	0	0	0	0	0	0	0	0	0	0	22	3	25	0	0	0	49	15:00 - 16:00	224	
15:15 - 15:30	25	1	26	0	0	0	0	0	0	0	0	0	0	0	0	0	0	0	1	0	1	18	7	25	0	0	52	15:15 - 16:15	239	
15:30 - 15:45	27	3	30	0	0	0	0	0	0	0	0	0	0	0	0	0	0	0	0	0	21	2	23	0	0	0	53	15:30 - 16:30	238	
15:45 - 16:00	38	6	44	0	0	0	0	0	0	0	0	0	0	0	0	0	0	0	1	0	1	19	6	25	0	0	70	15:45 - 16:45	248	
16:00 - 16:15	28	5	33	0	0	0	0	0	0	0	0	0	0	0	0	0	0	0	0	0	27	4	31	0	0	0	64	16:00 - 17:00	222	
16:15 - 16:30	18	4	22	1	0	1	0	0	0	0	0	0	0	1	1	0	0	0	0	0	22	5	27	0	0	0	51	16:15 - 17:15	206	
16:30 - 16:45	27	2	29	0	0	0	0	0	0	0	0	0	0	0	0	0	0	0	0	0	29	5	34	0	0	0	63	16:30 - 17:30	198	
16:45 - 17:00																														

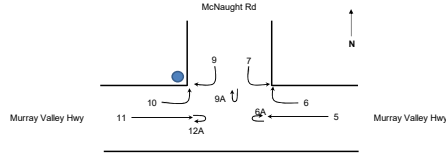

Client : RMA Engineers  
 Job : Torrumberry & Patho Intersection Counts  
 Day/Date : Wednesday, 7 May 2025  
 Survey Location : Murray Valley Hwy & McNaught Rd  
 Weather : Fine

18:30 - 18:45	14	2	16	0	0	0	0	0	0	0	0	0	0	0	0	0	0	0	0	0	7	4	11	0	0	0	27	18:30 - 19:30	71
18:45 - 19:00	8	3	11	0	0	0	0	0	0	0	0	0	0	1	0	1	0	0	0	1	3	1	4	0	0	0	17	18:45 - 19:45	57
19:00 - 19:15	9	3	12	0	0	0	0	0	0	0	0	0	0	2	0	2	0	0	0	0	2	1	3	0	0	0	17	19:00 - 20:00	52
19:15 - 19:30	4	1	5	0	0	0	0	0	0	0	0	0	0	0	0	0	0	0	0	0	3	2	5	0	0	0	10	19:15 - 20:15	45
19:30 - 19:45	3	3	6	0	0	0	0	0	0	0	0	0	0	0	0	0	0	0	1	0	1	5	1	6	0	0	13	19:30 - 20:30	44
19:45 - 20:00	4	2	6	0	0	0	0	0	0	0	0	0	0	1	0	1	0	0	0	0	3	2	5	0	0	0	12	19:45 - 20:45	43
20:00 - 20:15	6	1	7	0	0	0	0	0	0	0	0	0	0	0	0	0	0	0	0	0	3	0	3	0	0	0	10	20:00 - 21:00	46
20:15 - 20:30	7	0	7	0	0	0	0	0	0	0	0	0	0	0	0	0	0	0	0	0	1	1	2	0	0	0	9	AM Peak	230
20:30 - 20:45	3	7	10	0	0	0	0	0	0	0	0	0	0	0	0	0	0	0	0	0	2	0	2	0	0	0	12	PM Peak	248
20:45 - 21:00	6	2	8	0	0	0	0	0	0	0	0	0	0	0	0	0	0	0	0	0	4	3	7	0	0	0	15		
<b>Total</b>	<b>1064</b>	<b>249</b>	<b>1313</b>	<b>5</b>	<b>1</b>	<b>6</b>	<b>1</b>	<b>0</b>	<b>1</b>	<b>6</b>	<b>1</b>	<b>7</b>	<b>10</b>	<b>4</b>	<b>14</b>	<b>0</b>	<b>0</b>	<b>0</b>	<b>13</b>	<b>3</b>	<b>16</b>	<b>1084</b>	<b>252</b>	<b>1336</b>	<b>0</b>	<b>0</b>	<b>0</b>	<b>2693</b>	
<b>AM Peak</b>	<b>75</b>	<b>20</b>	<b>95</b>	<b>0</b>	<b>1</b>	<b>1</b>	<b>0</b>	<b>0</b>	<b>0</b>	<b>0</b>	<b>0</b>	<b>0</b>	<b>1</b>	<b>0</b>	<b>1</b>	<b>0</b>	<b>0</b>	<b>0</b>	<b>0</b>	<b>0</b>	<b>123</b>	<b>10</b>	<b>133</b>	<b>0</b>	<b>0</b>	<b>0</b>	<b>230</b>		
<b>PM Peak</b>	<b>111</b>	<b>17</b>	<b>128</b>	<b>1</b>	<b>0</b>	<b>1</b>	<b>0</b>	<b>0</b>	<b>0</b>	<b>0</b>	<b>0</b>	<b>0</b>	<b>1</b>	<b>1</b>	<b>0</b>	<b>0</b>	<b>0</b>	<b>1</b>	<b>0</b>	<b>1</b>	<b>97</b>	<b>20</b>	<b>117</b>	<b>0</b>	<b>0</b>	<b>0</b>	<b>248</b>		

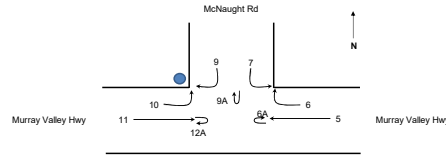

Client : RMA Engineers  
 Job : Torrumberry & Patho Intersection Counts  
 Day/Date : Wednesday, 7 May 2025  
 Survey Location : Murray Valley Hwy & McNaught Rd  
 Weather : Fine

HOURLY FLOW

TIME PERIOD	Movement 5			Movement 6			Movement 6A			Movement 7			Movement 9			Movement 9A			Movement 10			Movement 11			Movement 12A			Grand Total		
	Light	Heavy	Total	Light	Heavy	Total	Light	Heavy	Total	Light	Heavy	Total	Light	Heavy	Total	Light	Heavy	Total	Light	Heavy	Total	Light	Heavy	Total	Light	Heavy	Total	Light	Heavy	Total
3:00 - 4:00	1	7	8	0	0	0	0	0	0	0	0	0	0	0	0	0	0	0	0	0	0	2	2	4	0	0	0	3	9	12
3:15 - 4:15	1	7	8	0	0	0	0	0	0	0	0	0	0	0	0	0	0	0	0	0	0	3	1	4	0	0	0	4	8	12
3:30 - 4:30	1	5	6	0	0	0	0	0	0	0	0	0	0	0	0	0	0	0	0	0	2	0	2	0	0	0	3	5	8	
3:45 - 4:45	1	4	5	0	0	0	0	0	0	0	0	0	0	0	0	0	0	0	0	0	4	0	4	0	0	0	5	4	9	
4:00 - 5:00	1	2	3	0	0	0	0	0	0	0	0	0	0	0	0	0	0	0	0	0	3	1	4	0	0	0	4	3	7	
4:15 - 5:15	2	5	7	0	0	0	0	0	0	0	0	0	0	0	0	0	0	0	0	0	9	1	10	0	0	0	11	6	17	
4:30 - 5:30	3	7	10	0	0	0	0	0	0	0	0	0	0	0	0	0	0	1	0	1	12	2	14	0	0	0	16	9	25	
4:45 - 5:45	4	10	14	0	0	0	0	0	0	0	0	0	0	0	0	0	0	2	0	2	14	2	16	0	0	0	20	12	32	
5:00 - 6:00	8	9	17	0	0	0	0	0	0	0	0	0	0	0	0	0	0	2	0	2	20	1	21	0	0	0	30	10	40	
5:15 - 6:15	8	10	18	0	0	0	0	0	0	0	0	0	0	0	0	0	0	2	0	2	19	4	23	0	0	0	29	14	43	
5:30 - 6:30	21	12	33	0	0	0	0	0	0	0	0	0	0	0	0	0	0	1	0	1	29	6	35	0	0	0	51	18	69	
5:45 - 6:45	31	10	41	0	0	0	0	0	0	0	0	0	0	0	0	0	0	1	0	1	33	7	40	0	0	0	65	17	82	
6:00 - 7:00	36	19	55	0	0	0	0	0	0	0	0	0	0	0	0	0	0	1	0	1	37	9	46	0	0	0	74	28	102	
6:15 - 7:15	44	20	64	1	0	1	0	0	0	0	0	0	0	0	0	0	0	1	0	1	48	7	55	0	0	0	94	27	121	
6:30 - 7:30	52	23	75	1	0	1	0	0	0	0	0	0	0	0	0	0	0	1	0	1	56	9	65	0	0	0	110	32	142	
6:45 - 7:45	66	26	92	1	0	1	0	0	0	0	0	0	0	0	0	0	0	0	0	0	69	10	79	0	0	0	136	36	172	
7:00 - 8:00	86	22	108	1	0	1	0	0	0	0	0	0	0	0	0	0	0	0	0	0	82	13	95	0	0	0	169	35	204	
7:15 - 8:15	97	28	123	0	0	0	0	0	0	0	0	0	0	0	0	0	0	0	0	0	81	15	96	0	0	0	178	41	219	
7:30 - 8:30	101	27	128	0	0	0	0	0	0	0	0	0	0	0	0	0	0	1	0	1	86	13	99	0	0	0	188	40	228	
7:45 - 8:45	90	31	121	0	0	0	0	0	0	2	0	2	0	0	0	0	0	1	0	1	82	17	99	0	0	0	175	48	223	
8:00 - 9:00	84	31	115	0	0	0	0	0	0	2	0	2	0	0	0	0	0	1	0	1	82	13	95	0	0	0	169	44	213	
8:15 - 9:15	75	26	101	0	1	1	0	0	0	2	0	2	0	0	0	0	0	1	0	1	99	11	110	0	0	0	177	38	215	
8:30 - 9:30	63	22	85	0	1	1	0	0	0	2	0	2	1	0	1	0	0	0	0	0	108	15	123	0	0	0	174	38	212	
8:45 - 9:45	75	20	95	0	1	1	0	0	0	0	0	0	1	0	1	0	0	0	0	0	123	10	133	0	0	0	199	31	230	
9:00 - 10:00	69	22	91	0	1	1	1	0	1	0	0	0	1	0	1	0	0	0	0	0	124	12	136	0	0	0	195	35	230	
9:15 - 10:15	76	22	98	0	0	0	1	0	1	0	0	0	1	0	1	0	0	0	0	0	108	15	123	0	0	0	186	37	223	
9:30 - 10:30	77	23	100	0	0	0	1	0	1	1	0	1	0	0	0	0	0	1	0	1	105	11	116	0	0	0	185	34	219	
9:45 - 10:45	69	25	94	0	0	0	1	0	1	1	0	1	0	1	1	0	0	1	0	1	99	14	113	0	0	0	171	40	211	
10:00 - 11:00	74	24	98	0	0	0	0	0	0	1	0	1	0	1	1	0	0	0	1	0	100	15	115	0	0	0	176	40	216	
10:15 - 11:15	71	20	91	1	0	1	0	0	0	1	0	1	1	0	1	0	0	1	1	2	105	16	121	0	0	0	179	38	217	
10:30 - 11:30	87	19	106	1	0	1	0	0	0	0	0	0	1	2	3	0	0	0	1	1	2	91	20	111	0	0	0	181	42	223
10:45 - 11:45	91	16	107	1	0	1	0	0	0	0	0	0	3	1	4	0	0	0	1	2	3	84	22	106	0	0	0	180	41	221
11:00 - 12:00	86	14	100	1	0	1	0	0	0	1	0	1	3	2	5	0	0	0	1	2	3	83	25	108	0	0	0	175	43	218
11:15 - 12:15	83	15	98	0	0	0	0	0	0	1	1	2	3	2	5	0	0	0	2	1	3	72	30	102	0	0	0	161	49	210
11:30 - 12:30	75	17	92	0	0	0	0	0	0	1	1	2	2	1	3	0	0	0	2	1	3	76	32	108	0	0	0	156	52	208
11:45 - 12:45	70	15	85	0	0	0	0	0	0	1	1	2	0	1	1	0	0	0	2	0	2	75	31	106	0	0	0	148	48	196
12:00 - 13:00	71	12	83	1	0	1	0	0	0	0	0	1	0	0	0	0	0	0	2	0	2	66	32	98	0	0	0	140	45	185
12:15 - 13:15	81	14	95	1	0	1	0	0	0	1	0	1	0	0	0	0	0	0	1	0	1	77	32	109	0	0	0	161	46	207
12:30 - 13:30	67	12	79	1	0	1	0	0	0	1	0	1	0	0	0	0	0	0	1	0	1	77	32	109	0	0	0	147	44	191
12:45 - 13:45	64	12	76	2	0	2	0	0	0	1	0	1	0	0	0	0	0	0	1	0	1	74	34	108	0	0	0	142	46	188
13:00 - 14:00	76	13	89	1	0	1	0	0	0	2	0	2	1	0	1	0	0	0	1	0	1	80	30	110	0	0	0	161	43	204
13:15 - 14:15	80	14	94	1	0	1	0	0	0	1	0	1	1	0	1	0	0	0	1	1	2	74	27	101	0	0	0	158	42	200
13:30 - 14:30	100	13	113	1	0	1	0	0	0	1	0	1	1	0	1	0	0	0	1	1	80	27	107	0	0	0	183	41	224	
13:45 - 14:45	97	11	108	0	0	0	0	0	0	1	0	1	2	0	2	0	0	0	1	1	88	23	111	0	0	0	188	35	223	
14:00 - 15:00	91	12	103	0	0	0	0	0	0	0	0	0	1	0	1	0	0	0	0	1	1	93	22	115	0	0	0	185	35	220
14:15 - 15:15	87	9	96	0	0	0	0	0	0	0	0	0	0	1	0	1	0	0	0	0	99	18	117	0	0	0	187	27	214	
14:30 - 15:30	83	7	90	0	0	0	0	0	0	0	0	0	1	0	1	0	0	0	1	0	1	89	16	105	0	0	0	174	23	197
14:45 - 15:45	98	9	107	0	0	0	0	0	0	0	0	0	0	0	0	0	0	0	1	0	1	87	15	102	0	0	0	186	24	210
15:00 - 16:00	112	12	124	0	0	0	0	0	0	0	0	0	0	0	0	0	0	2	0	2	80	18	98	0	0	0	194	30	224	
15:15 - 16:15	118	15	133	0	0	0	0	0	0	0	0	0	0	0	0	0	0	2	0	2	85	19	104	0	0	0	205	34	239	
15:30 - 16:30	111	18	129	1	0	1	0	0	0	0	0	0	0	1	1	0	0	0	1	0	1	89	17	106	0	0	0	202	36	238
15:45 - 16:45	111	17	128	1	0	1	0	0	0	0	0	0	0	1	1	0	0	0	1	0	1	97	20	117	0	0	0	210	38	248
16:00 - 17:00	92	12	104	1	0	1	0	0	0	0	0	0	0	1	1	0	0	0	0	0	98	18	116	0	0	0	191	31	222	
16:15 - 17:15	92	7	99	1	0	1	0	0	0	0	0	0	0	1	1	0	0	0	0	0	87	18	105	0	0	0	180	26	206	
16:30 - 17:30	89	9	98	0	0	0	0	0	0	0	0	0	0	0	0	0	0	0	0	0	86	14	100	0	0	0	175	23	198	
16:45 - 17:45	81	11	92	0	0	0	0	0	0	0	0	0	0	0	0	0	0	0	0	0	70	13	83	0	0	0	151	24	175	

Client : RMA Engineers  
 Job : Torrumberry & Patho Intersection Counts  
 Day/Date : Wednesday, 7 May 2025  
 Survey Location : Murray Valley Hwy & McNaught Rd  
 Weather : Fine

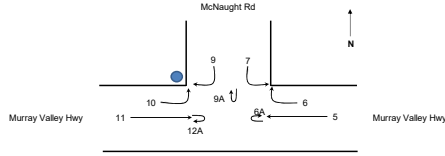

18:45 - 19:45	24	10	34	0	0	0	0	0	0	0	0	0	0	0	3	0	3	0	0	0	2	0	2	13	5	18	0	0	0	42	15	57
19:00 - 20:00	20	9	29	0	0	0	0	0	0	0	0	0	0	3	0	3	0	0	0	1	0	1	13	6	19	0	0	0	37	15	52	
19:15 - 20:15	17	7	24	0	0	0	0	0	0	0	0	0	0	1	0	1	0	0	0	1	0	1	14	5	19	0	0	0	33	12	45	
19:30 - 20:30	20	6	26	0	0	0	0	0	0	0	0	0	0	1	0	1	0	0	0	1	0	1	12	4	16	0	0	0	34	10	44	
19:45 - 20:45	20	10	30	0	0	0	0	0	0	0	0	0	0	1	0	1	0	0	0	0	0	0	9	3	12	0	0	0	30	13	43	
20:00 - 21:00	22	10	32	0	0	0	0	0	0	0	0	0	0	0	0	0	0	0	0	0	0	0	10	4	14	0	0	0	32	14	46	





PEAK HOUR VOLUME SUMMARY	
TOTAL VEHICLES	
Volume	AM (PM)
Scenario	Count Data (Network Peak)
Year	2025

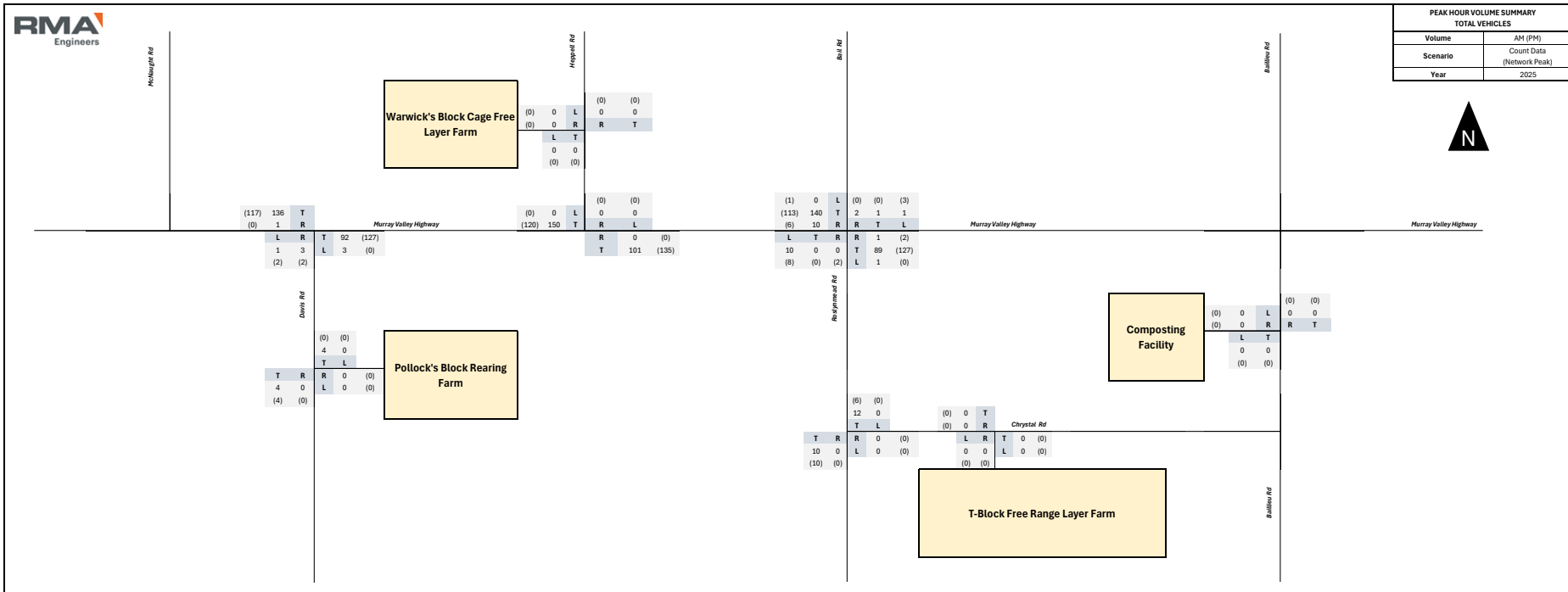

PEAK HOUR VOLUME SUMMARY TOTAL VEHICLES	
Volume	AM (PM)
Scenario	Count Data (Development Peak 1)
Year	2025

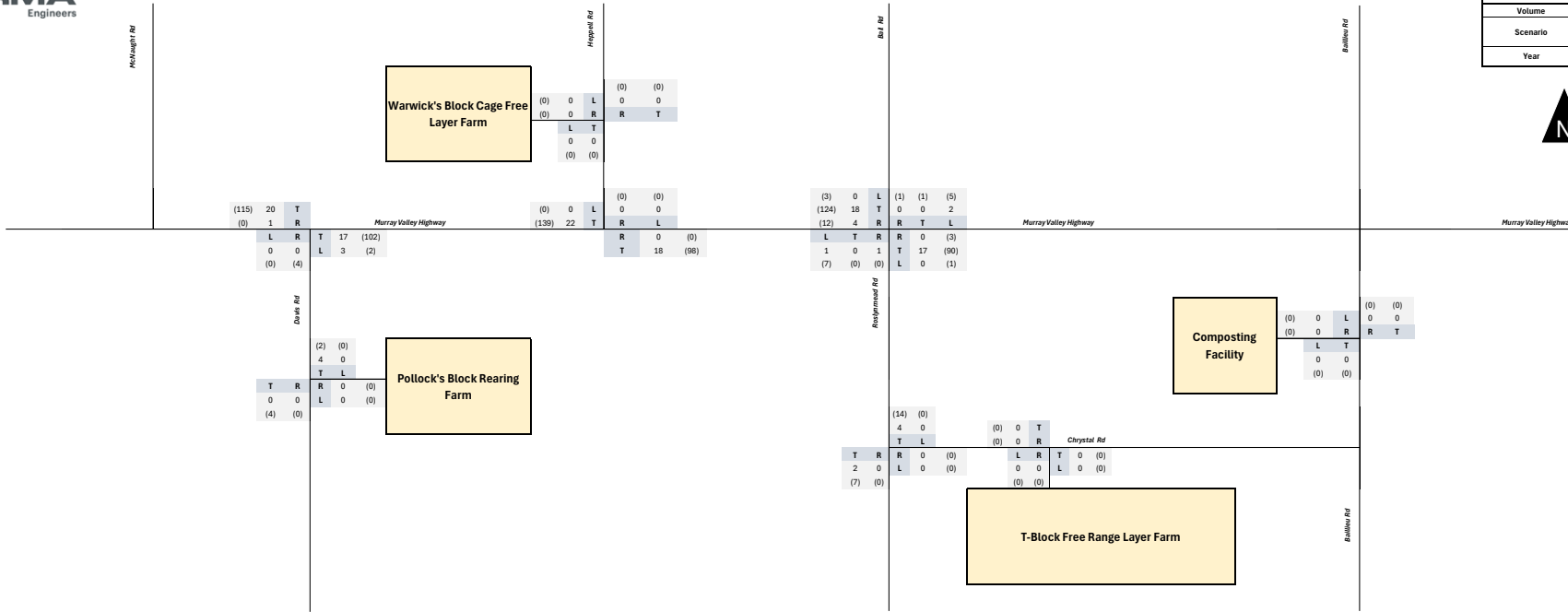

PEAK HOUR VOLUME SUMMARY	
TOTAL VEHICLES	
Volume	AM (PM)
Scenario	Count Data (Development Peak 2)
Year	2025

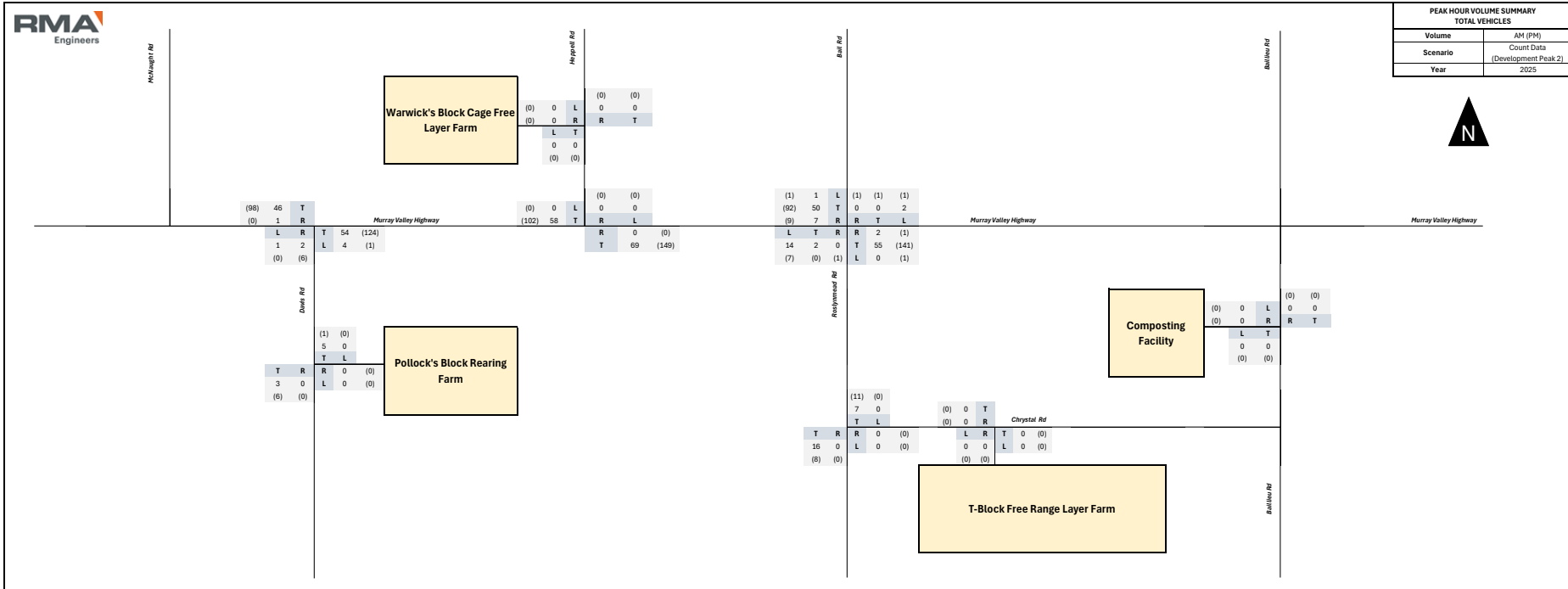

TRAFFIC VOLUME SUMMARY	
TOTAL VEHICLES	
Volume	12hrs (7am-7pm)
Scenario	Count Data
Year	2025

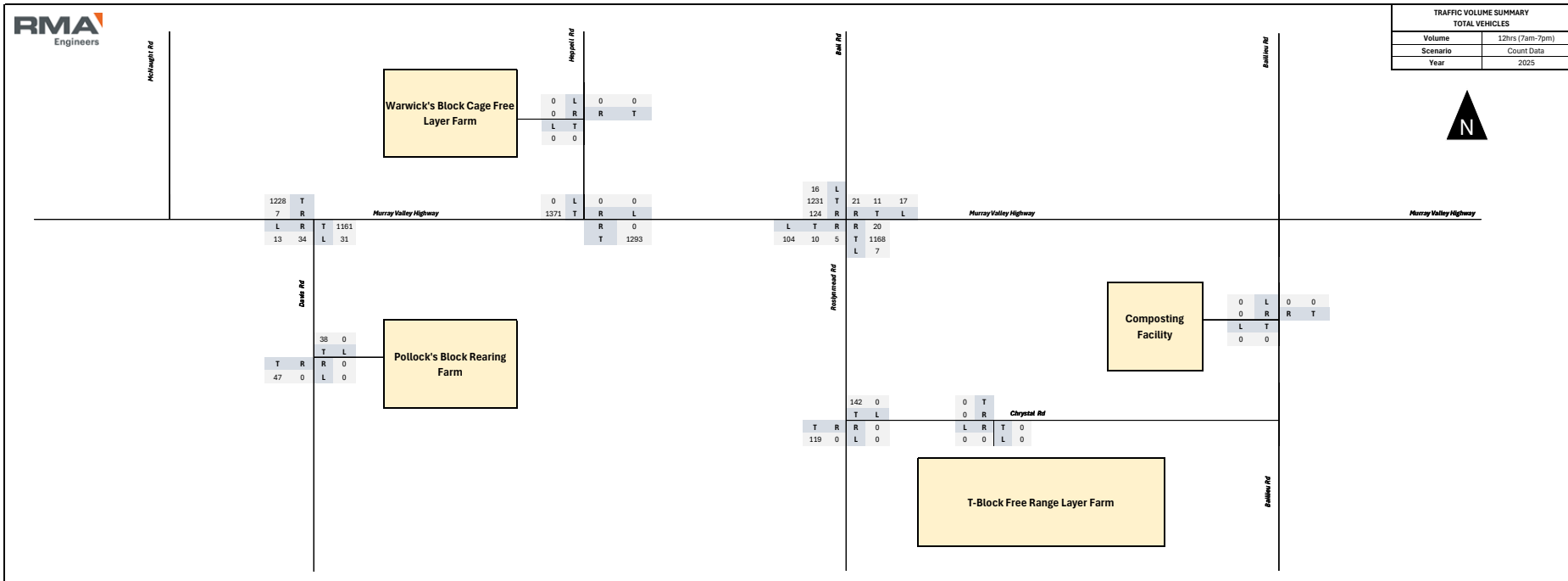

TRAFFIC VOLUME SUMMARY	
TOTAL VEHICLES	
Volume	24hrs
Scenario	Count Data
Year	2025

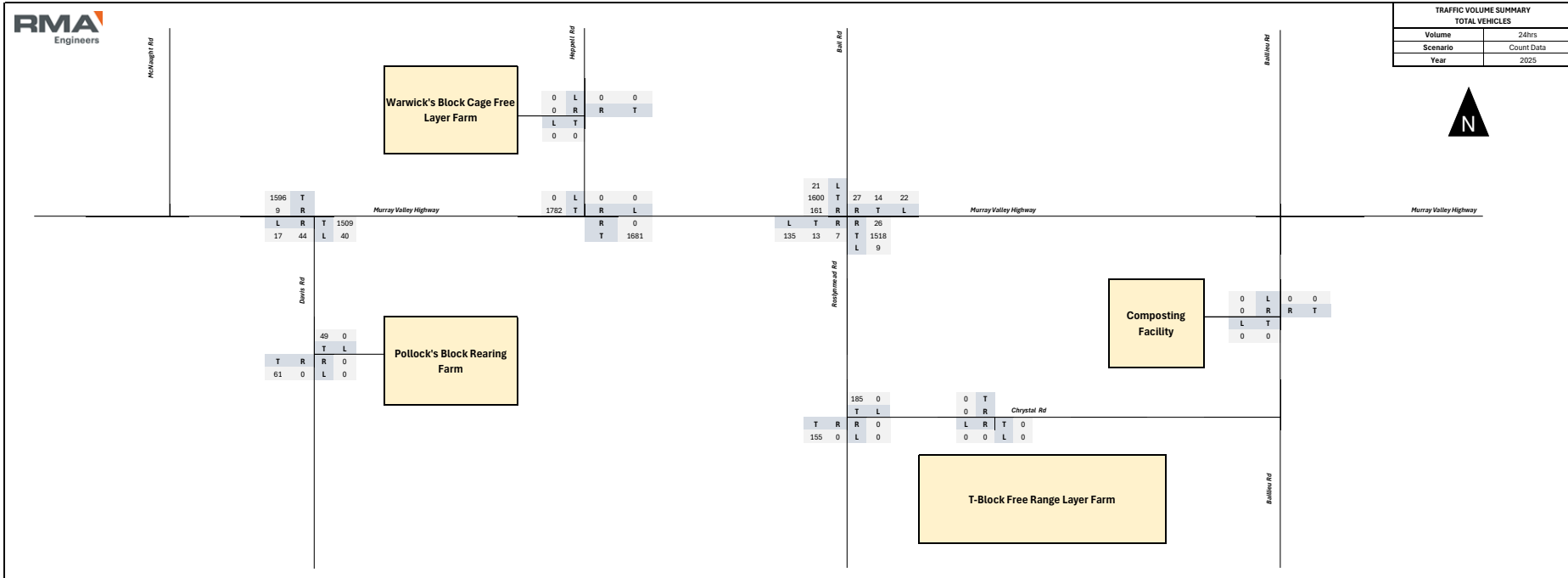

PEAK HOUR VOLUME SUMMARY	
LIGHT VEHICLES	
Volume	AM (PM)
Scenario	Count Data (Network Peak)
Year	2025

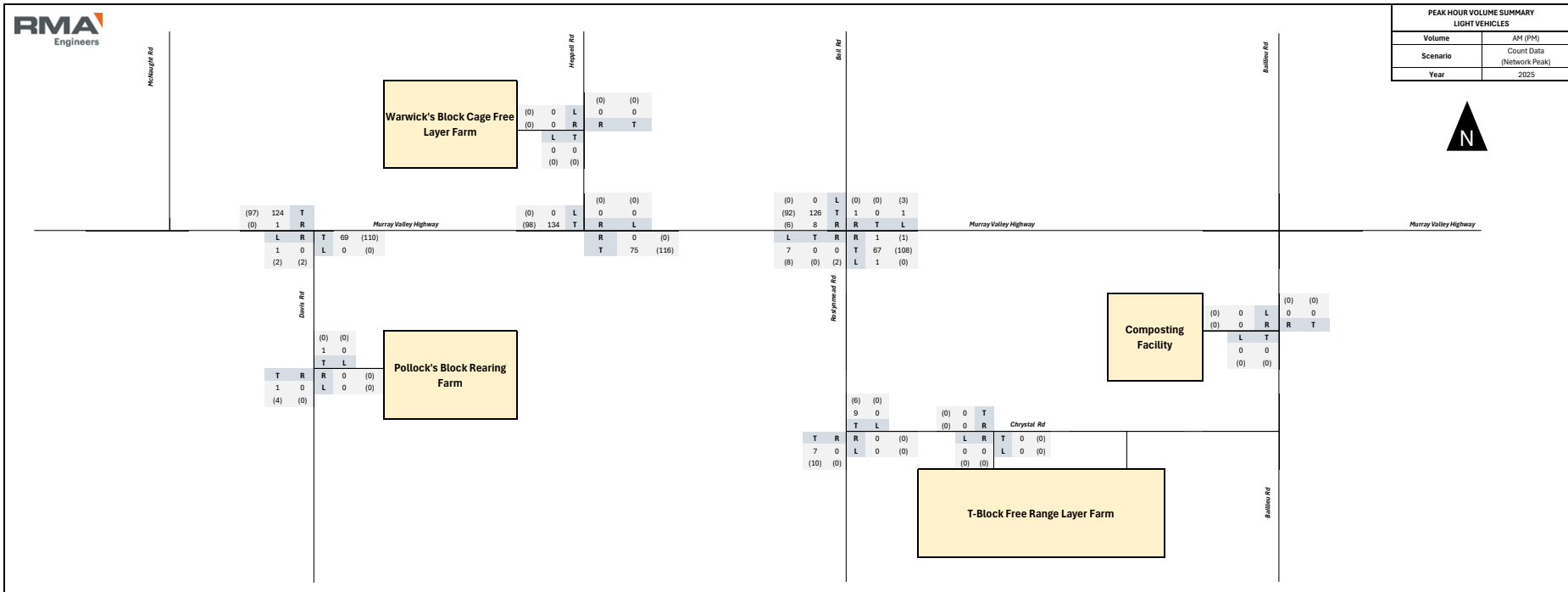

PEAK HOUR VOLUME SUMMARY LIGHT VEHICLES	
Volume	AM (PM)
Scenario	Count Data (Development Peak 1)
Year	2025

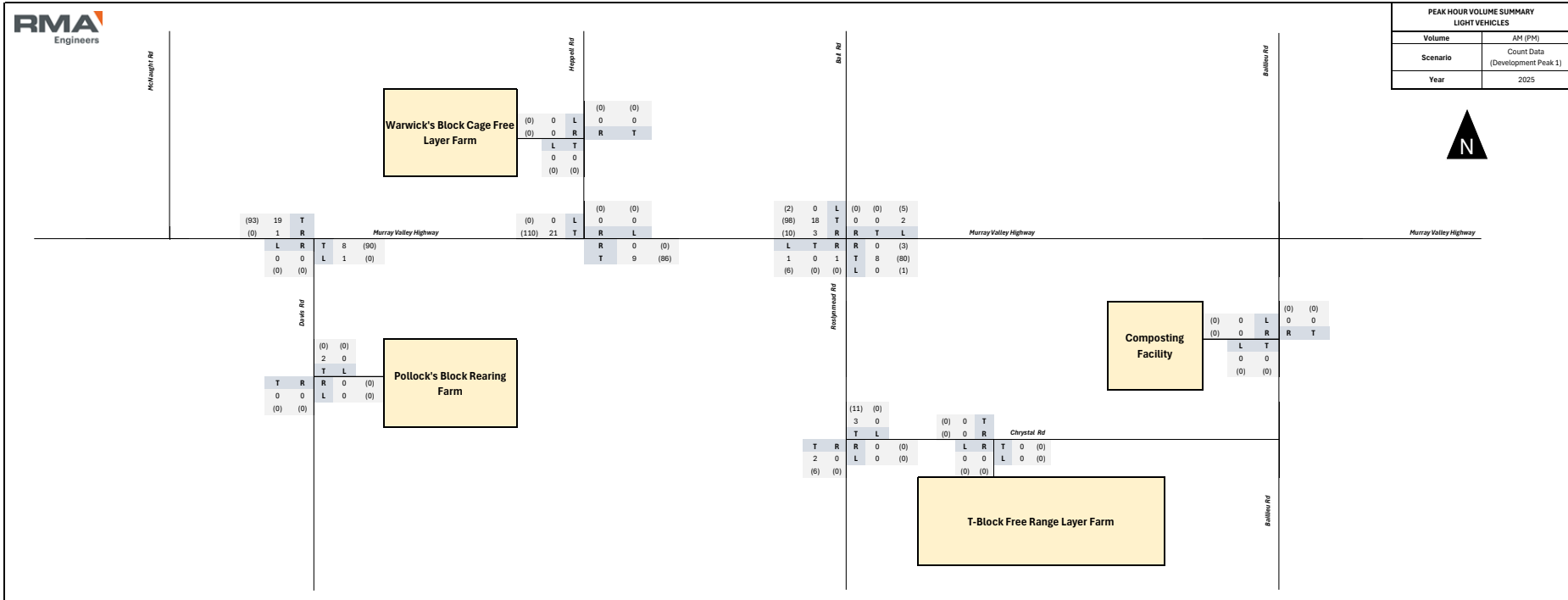

PEAK HOUR VOLUME SUMMARY LIGHT VEHICLES	
Volume	AM (PM)
Scenario	Count Data (Development Peak 2)
Year	2025

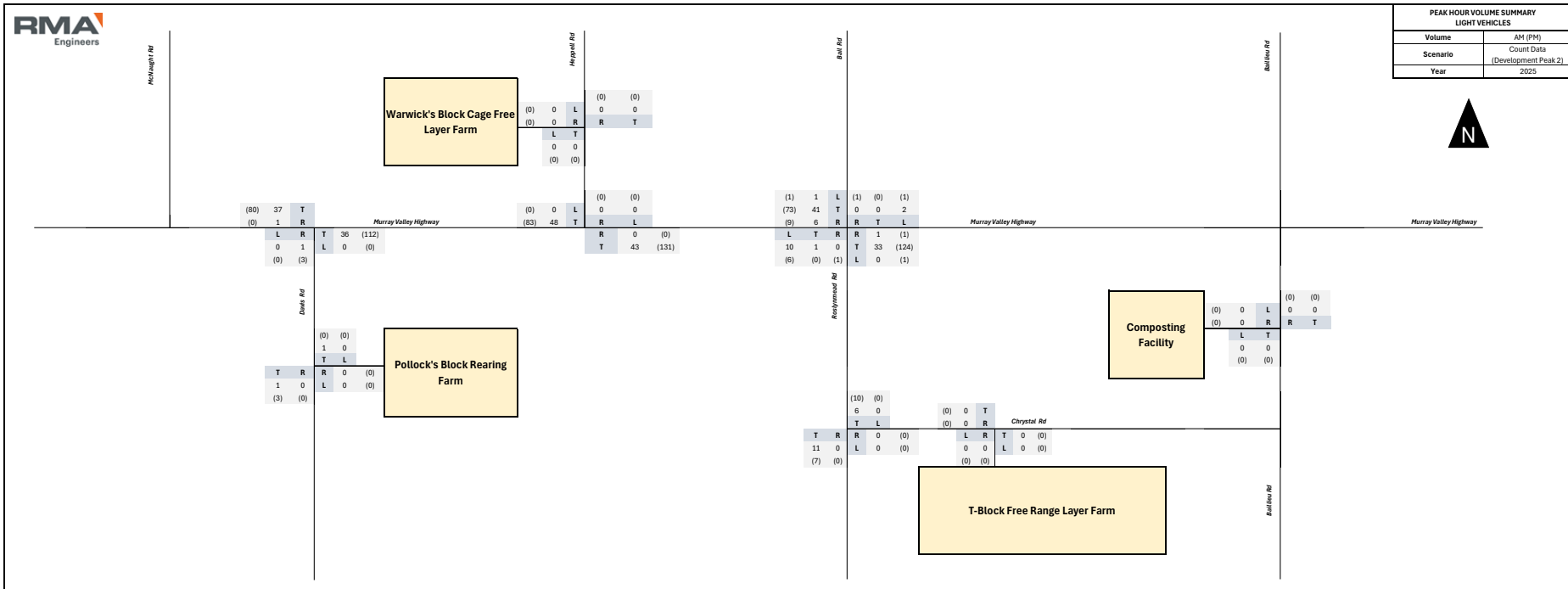

TRAFFIC VOLUME SUMMARY	
LIGHT VEHICLES	
Volume	12hrs (7am-7pm)
Scenario	Count Data
Year	2025

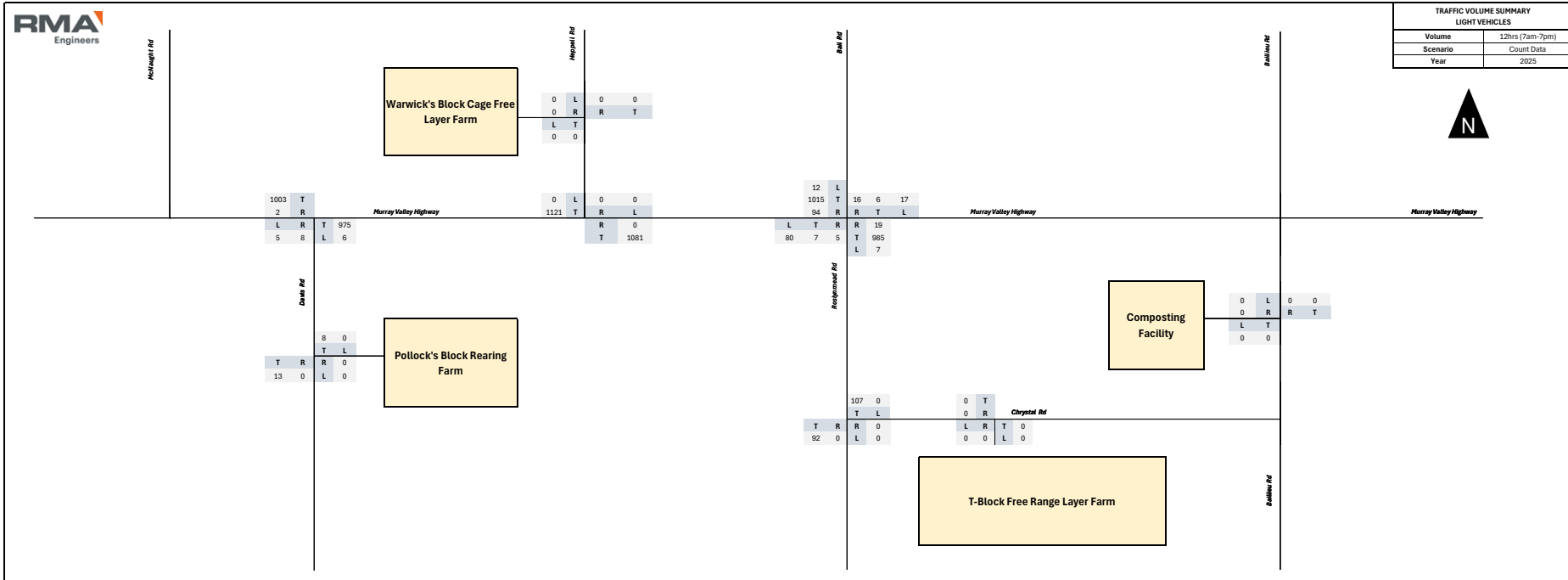

TRAFFIC VOLUME SUMMARY	
LIGHT VEHICLES	
Volume	24hrs
Scenario	Count Data
Year	2025

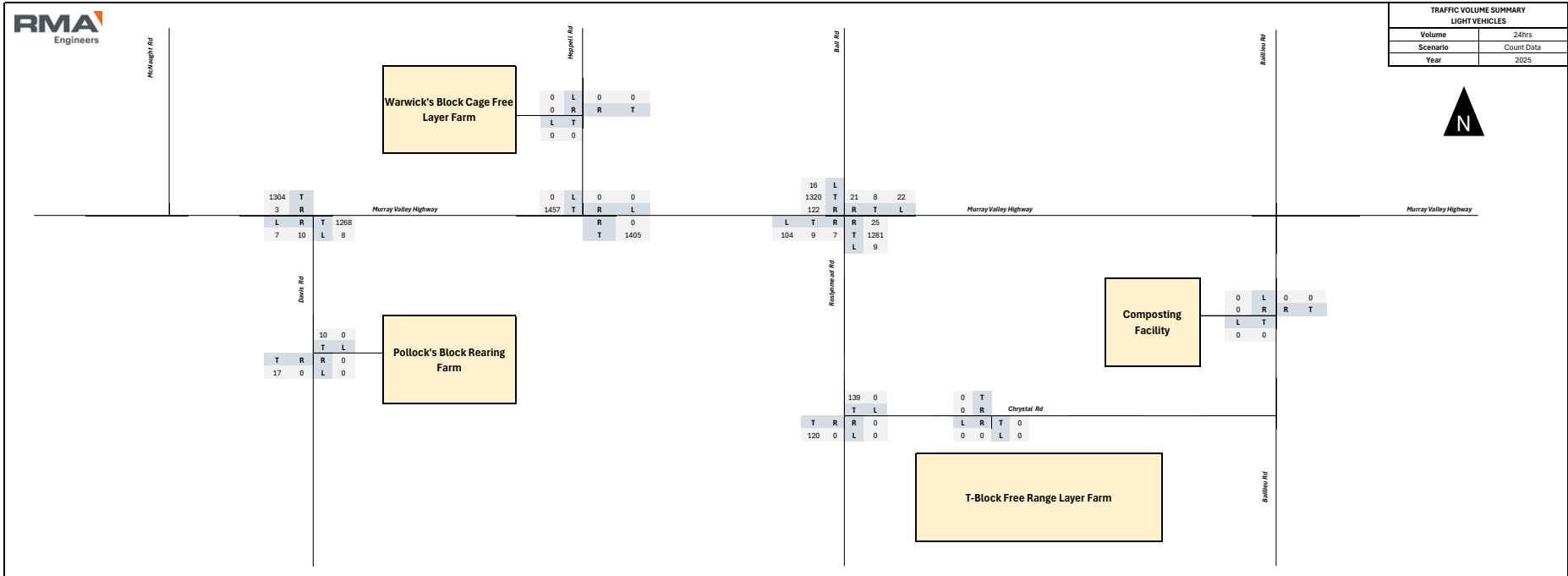

PEAK HOUR VOLUME SUMMARY	
HEAVY VEHICLES	
Volume	AM (PM)
Scenario	Count Data (Network Peak)
Year	2025

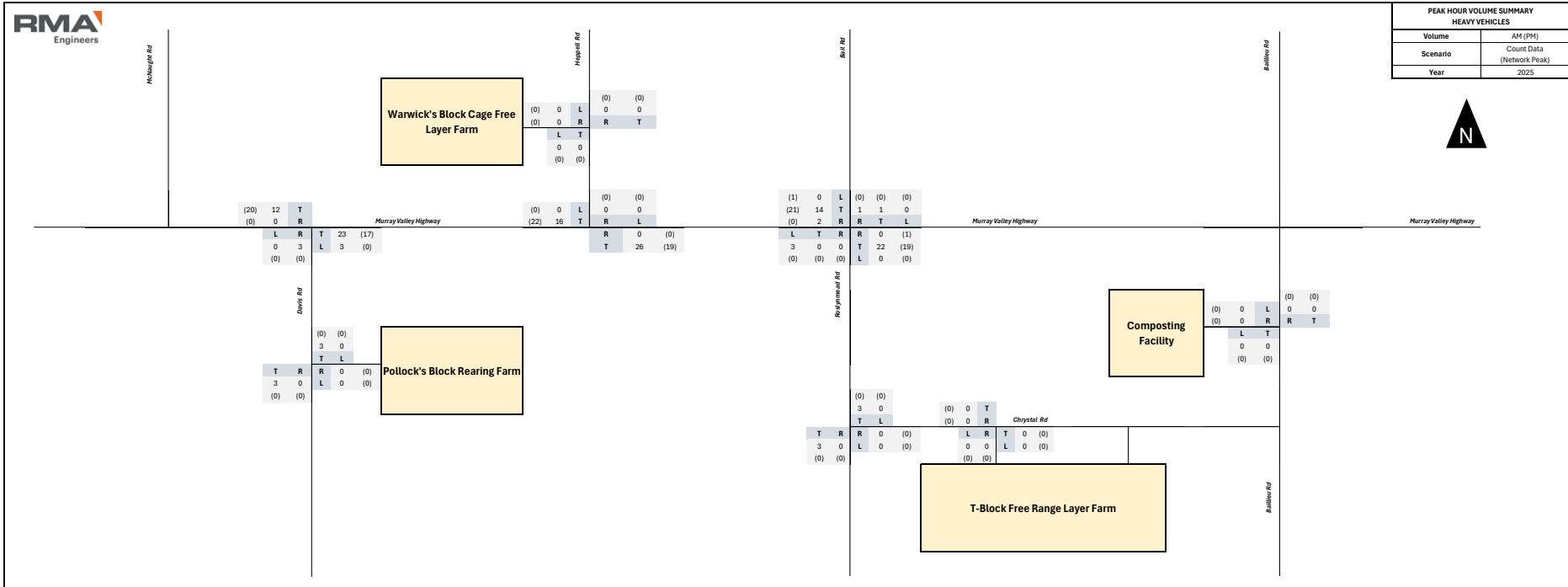

PEAK HOUR VOLUME SUMMARY HEAVY VEHICLES	
Volume	AM (PM)
Scenario	Count Data (Development Peak 1)
Year	2025

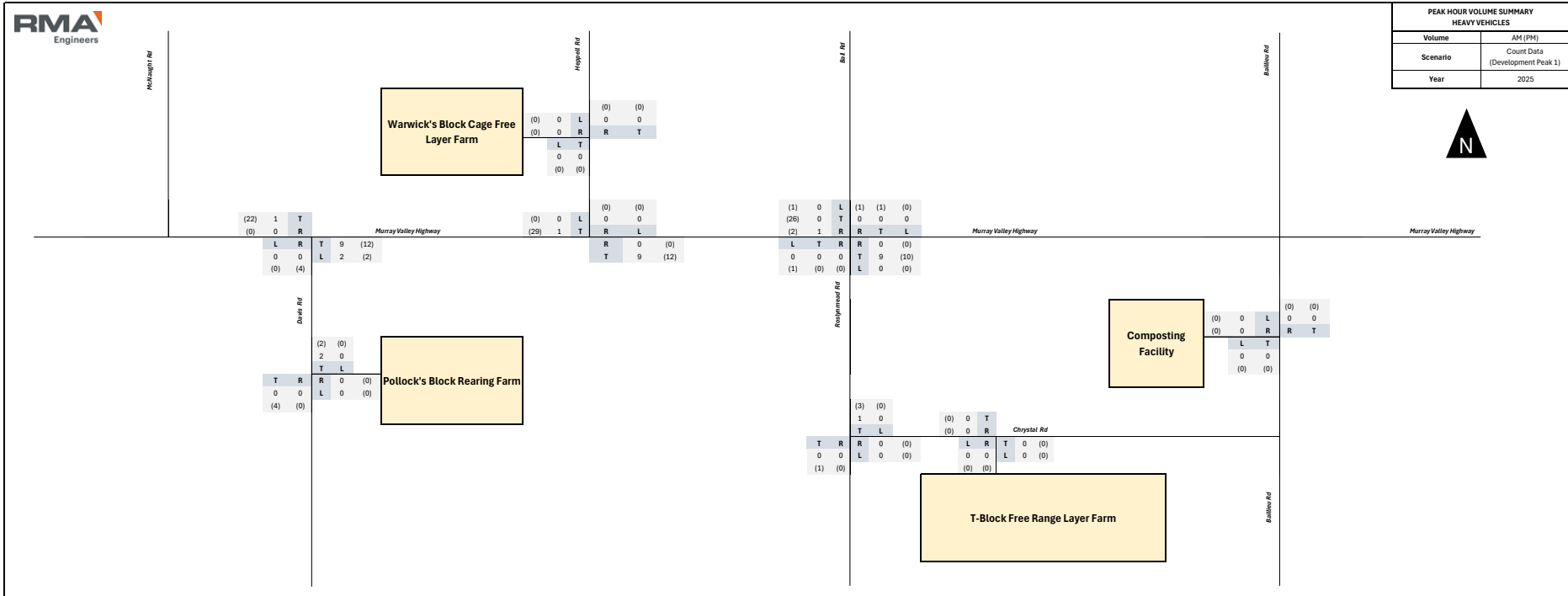

PEAK HOUR VOLUME SUMMARY	
HEAVY VEHICLES	
Volume	AM (PM)
Scenario	Count Data (Development Peak 2)
Year	2025

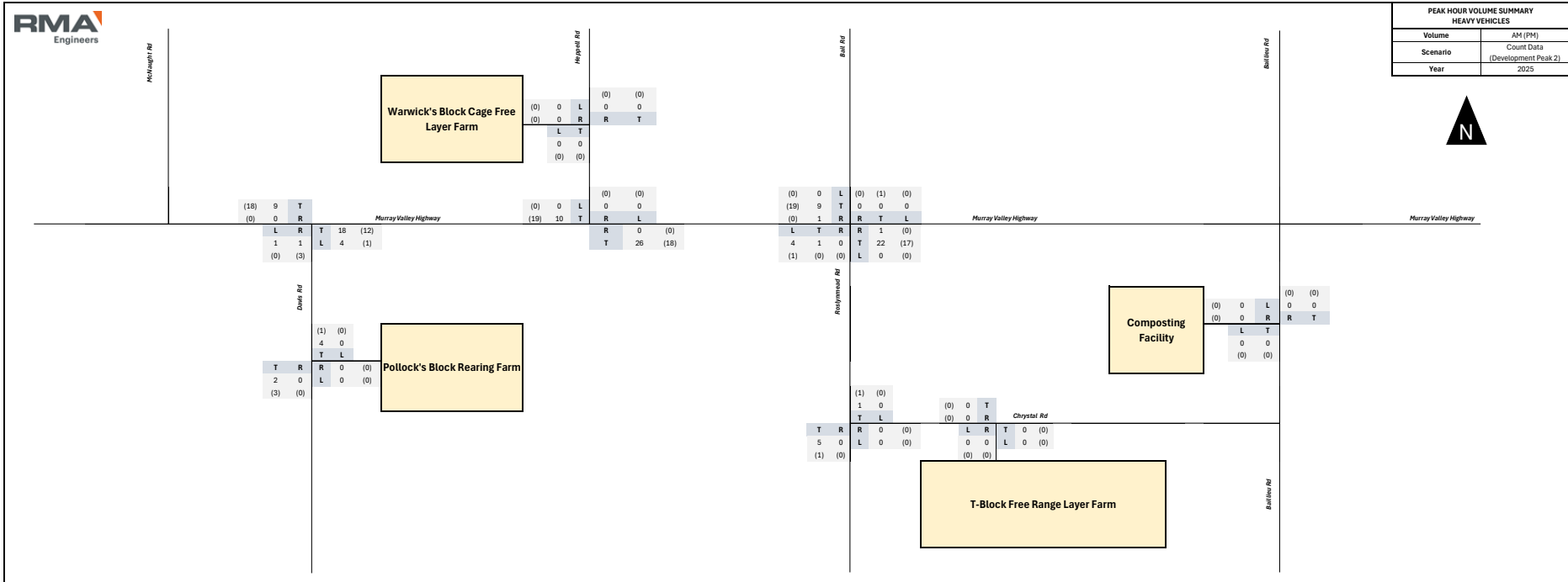

TRAFFIC VOLUME SUMMARY	
HEAVY VEHICLES	
Volume	12hrs (7am-7pm)
Scenario	Count Data
Year	2025

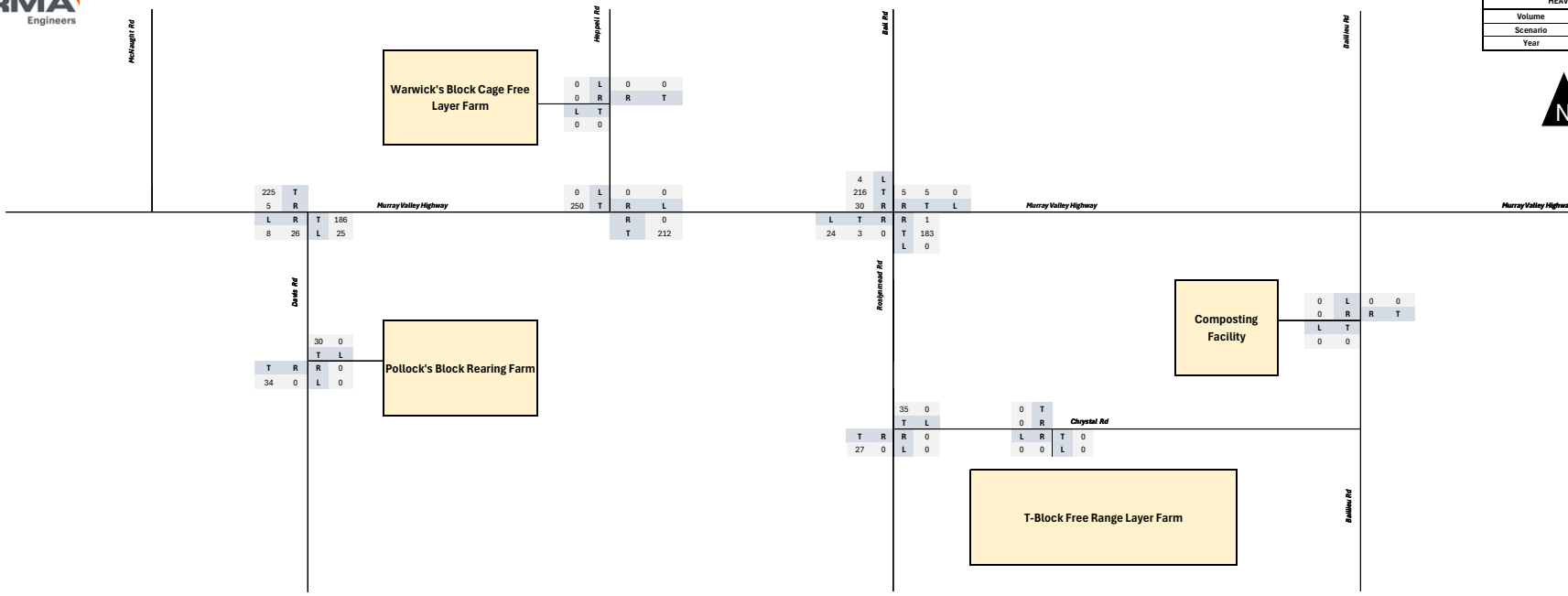

TRAFFIC VOLUME SUMMARY	
HEAVY VEHICLES	
Volume	24hrs
Scenario	Count Data
Year	2025

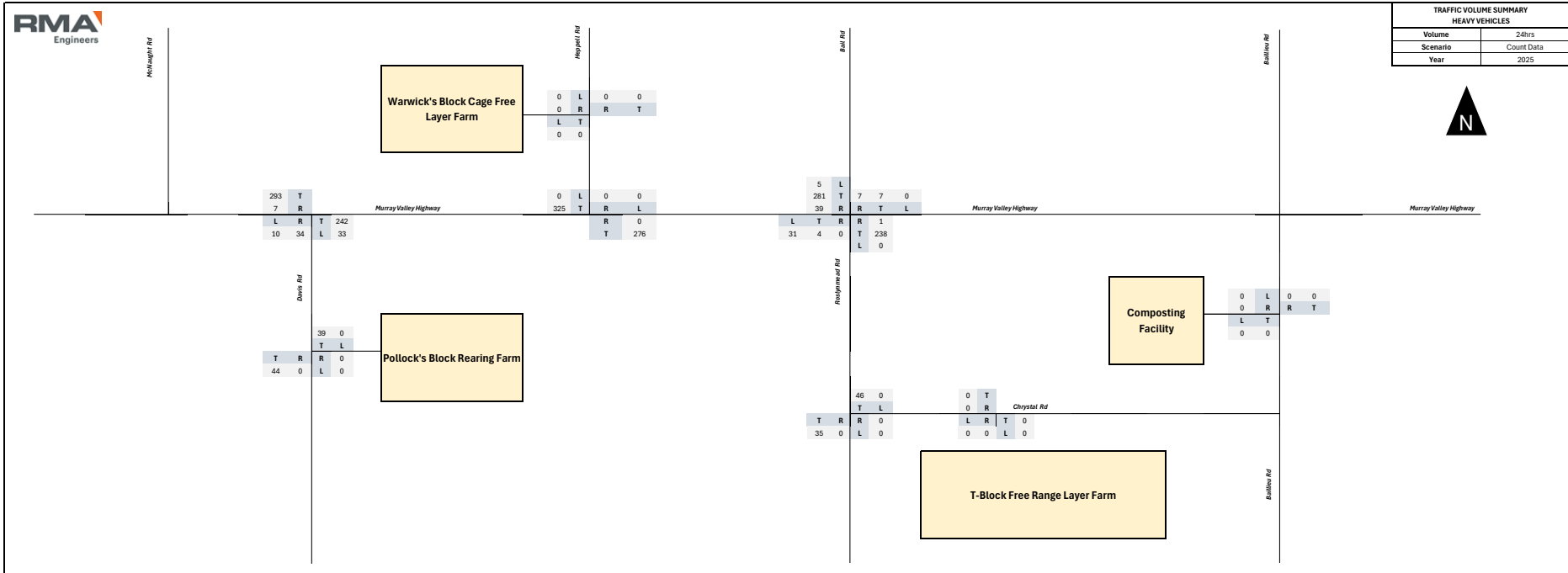

## Appendix D Background traffic volumes

PEAK HOUR VOLUME SUMMARY TOTAL VEHICLES	
Volume	AM (PM)
Scenario	Background (Network Peak)
Year	2042

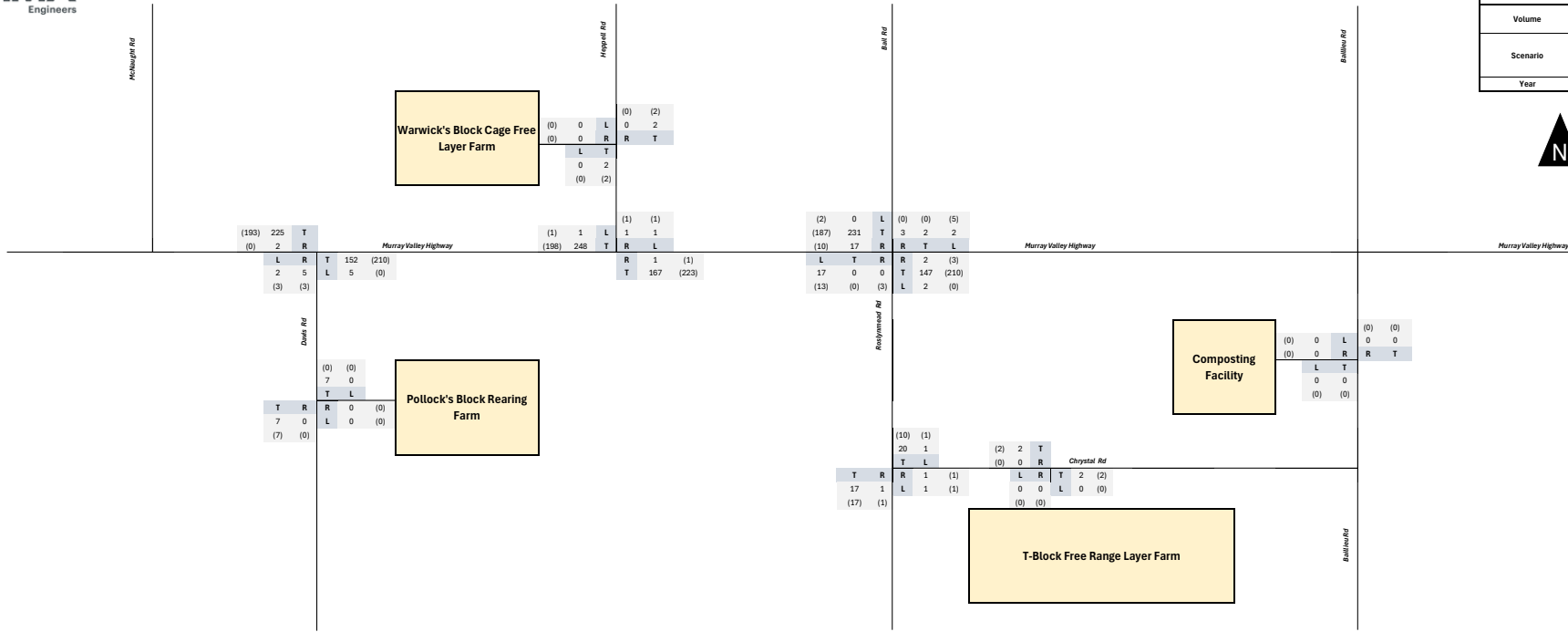

PEAK HOUR VOLUME SUMMARY TOTAL VEHICLES	
Volume	AM (PM)
Scenario	Background (Development Peak 1)
Year	2042

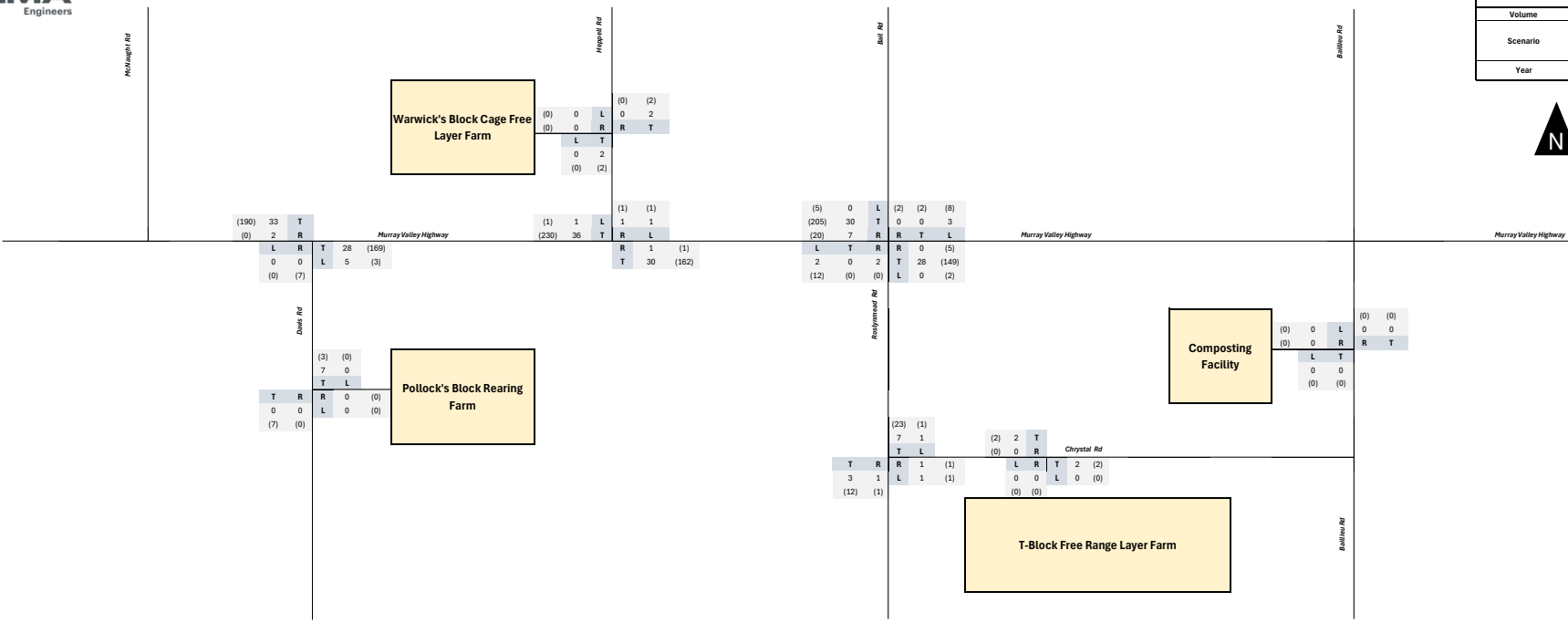

PEAK HOUR VOLUME SUMMARY	
TOTAL VEHICLES	
Volume	AM (PM)
Scenario	Background (Development Peak 2)
Year	2042

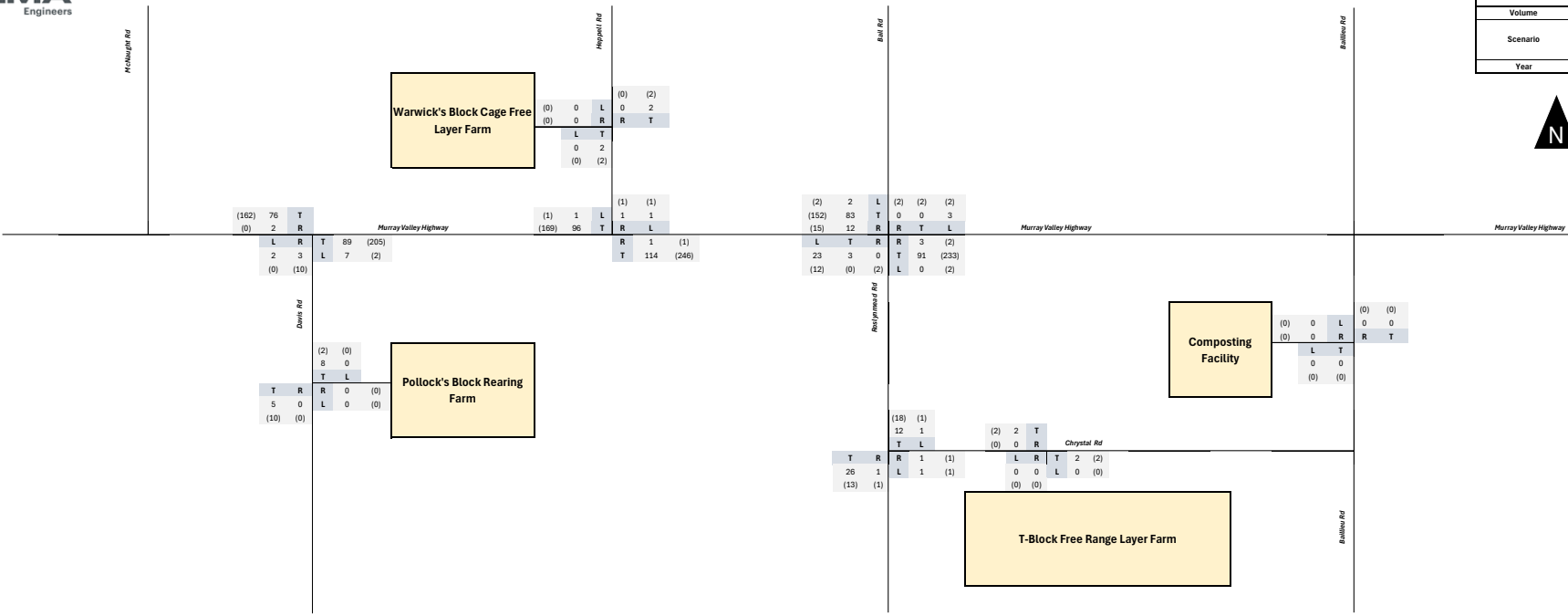

TRAFFIC VOLUME SUMMARY	
TOTAL VEHICLES	
Volume	Daily
Scenario	Background
Year	2042

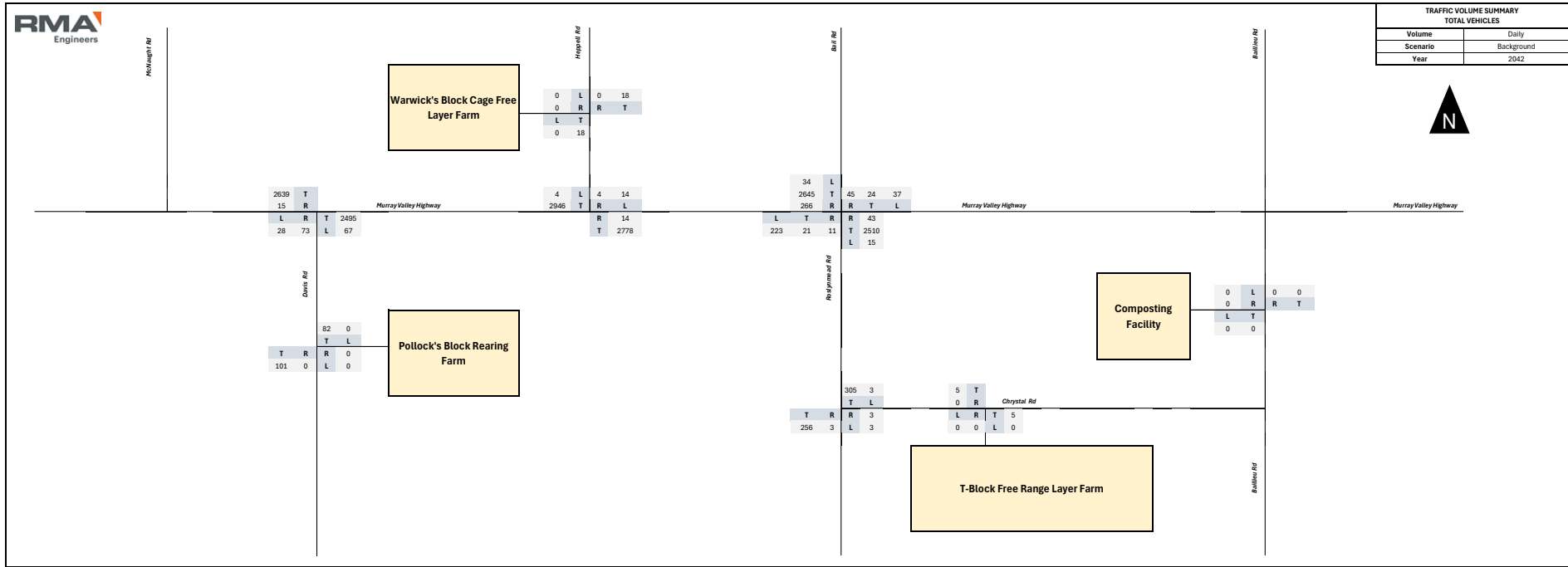

PEAK HOUR VOLUME SUMMARY LIGHT VEHICLES	
Volume	AM (PM)
Scenario	Background (Network Peak)
Year	2042

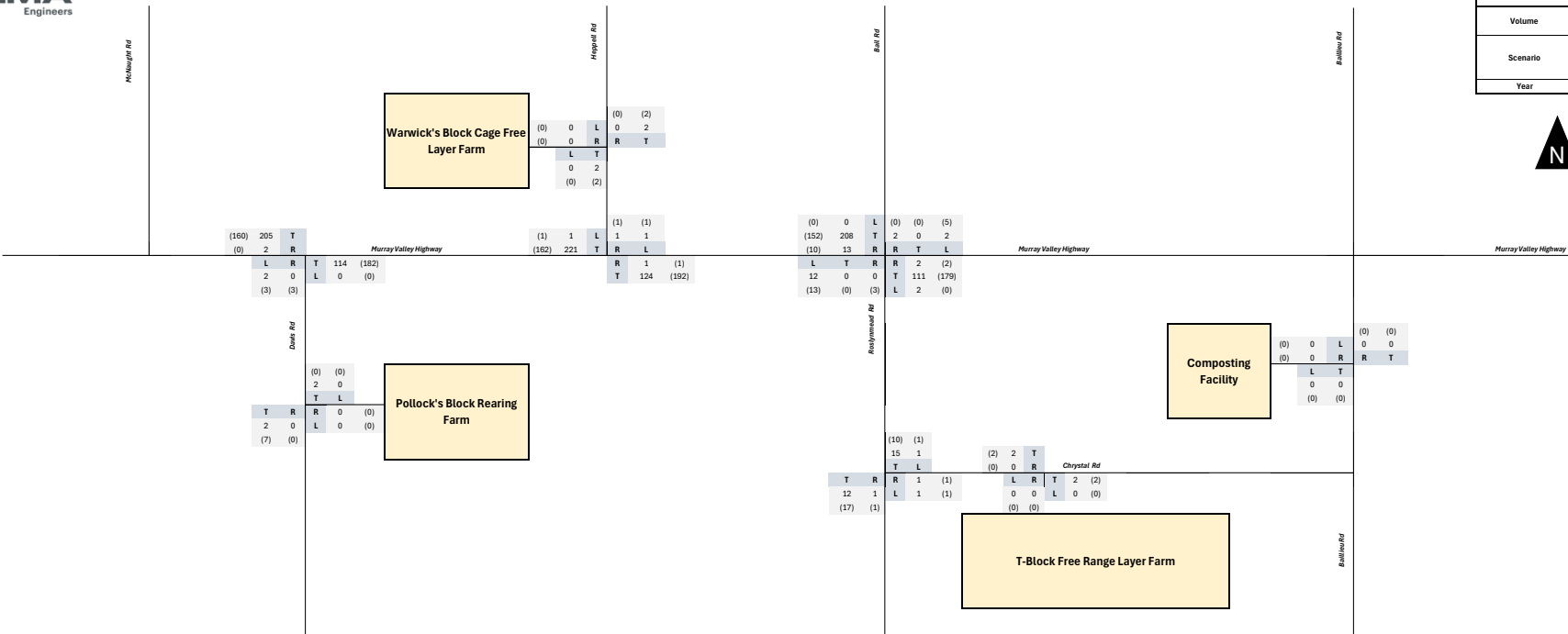

PEAK HOUR VOLUME SUMMARY LIGHT VEHICLES	
Volume	AM (PM)
Scenario	Background (Development Peak 1)
Year	2042

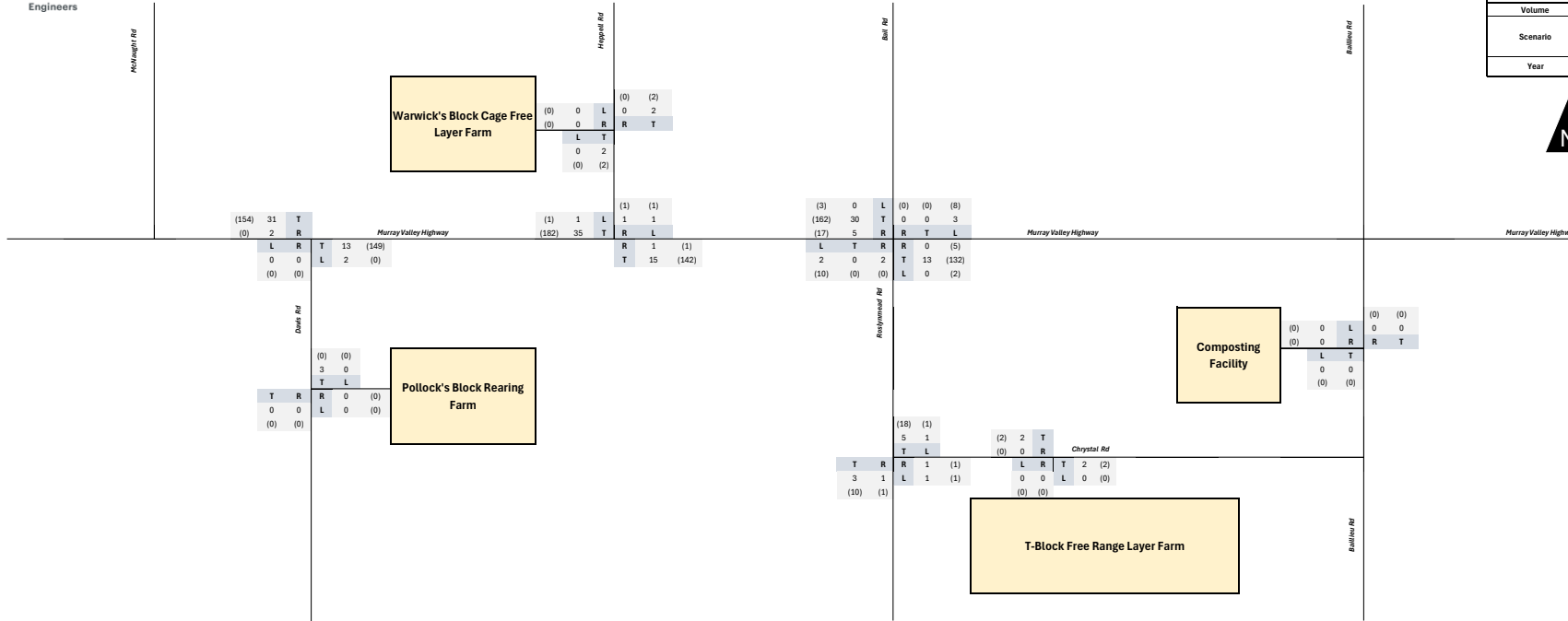

PEAK HOUR VOLUME SUMMARY LIGHT VEHICLES	
Volume	AM (PM)
Scenario	Background (Development Peak 2)
Year	2042

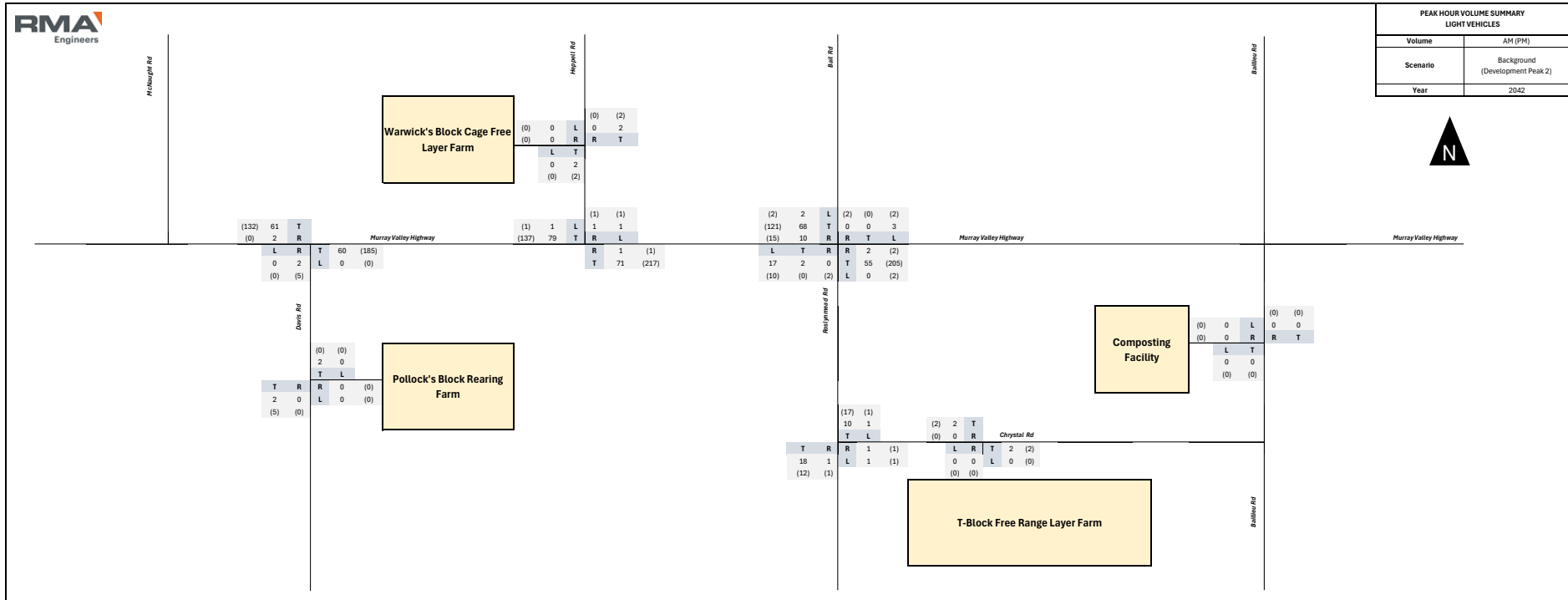

TRAFFIC VOLUME SUMMARY	
LIGHT VEHICLES	
Volume	Daily
Scenario	Background
Year	2042

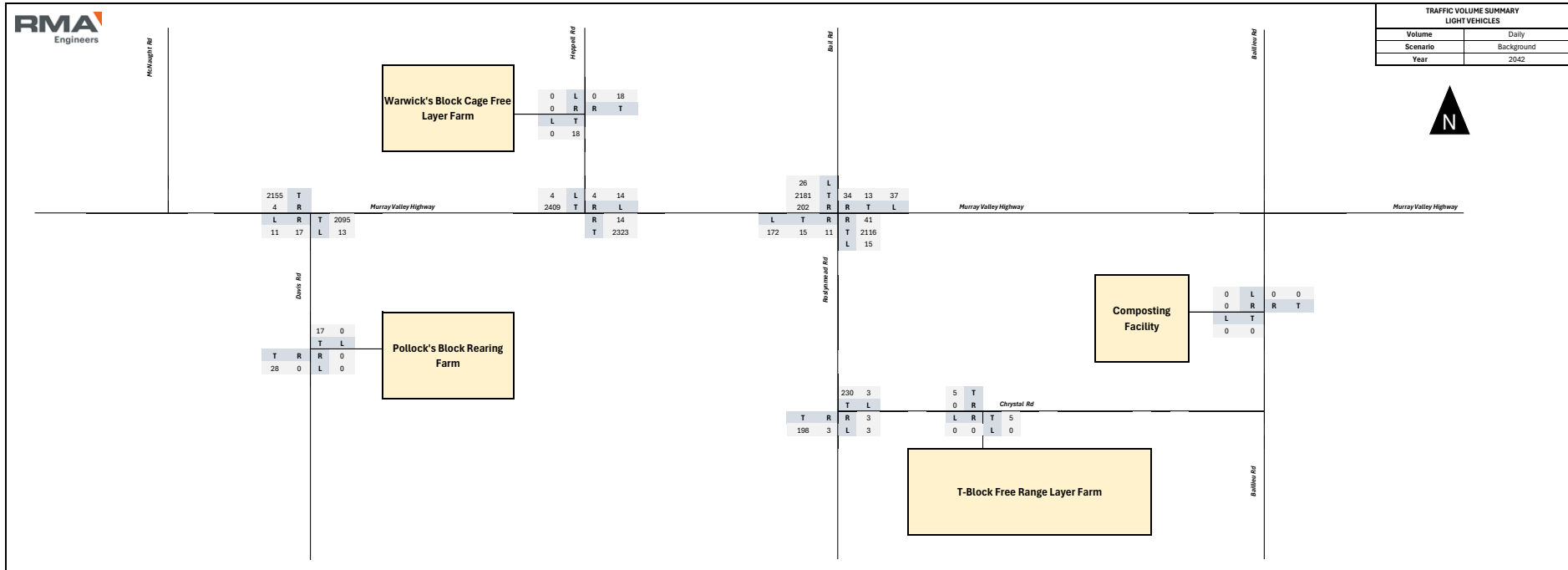

PEAK HOUR VOLUME SUMMARY HEAVY VEHICLES	
Volume	AM (PM)
Scenario	Background (Network Peak)
Year	2042

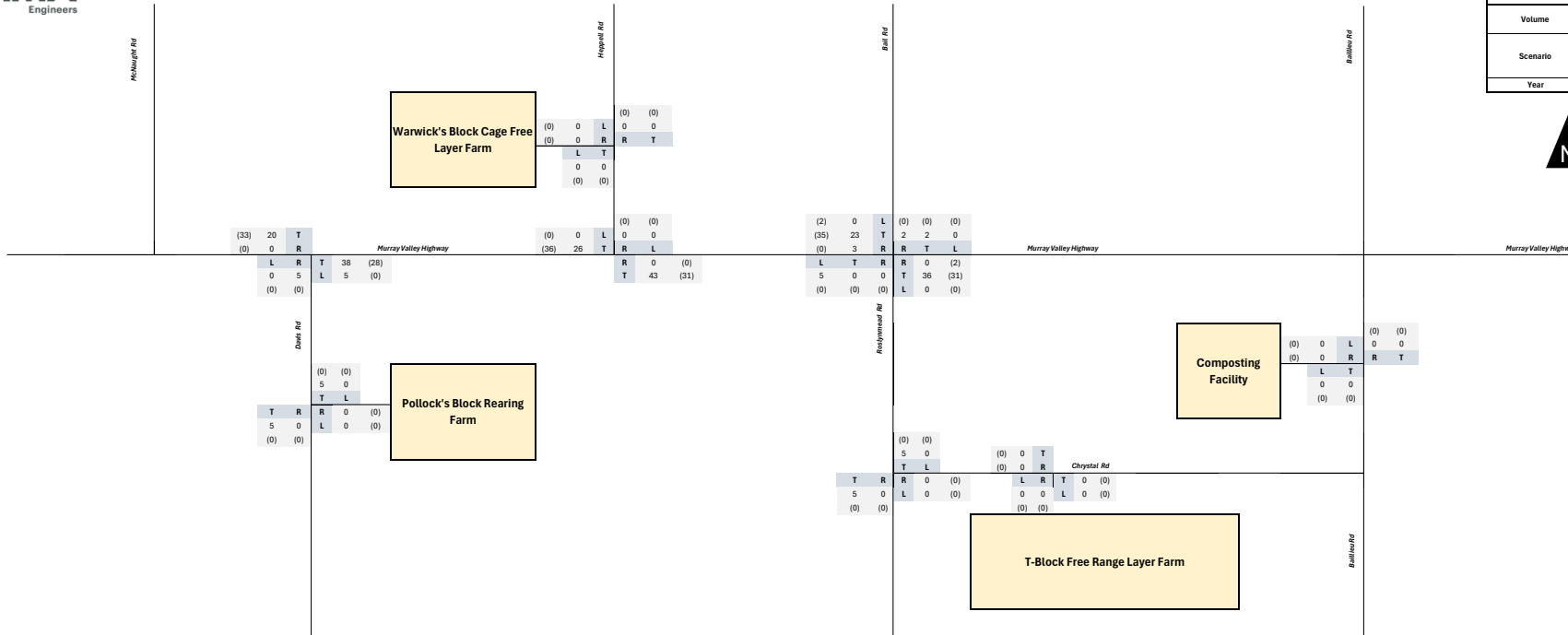

PEAK HOUR VOLUME SUMMARY HEAVY VEHICLES	
Volume	AM (PM)
Scenario	Background (Development Peak 1)
Year	2042

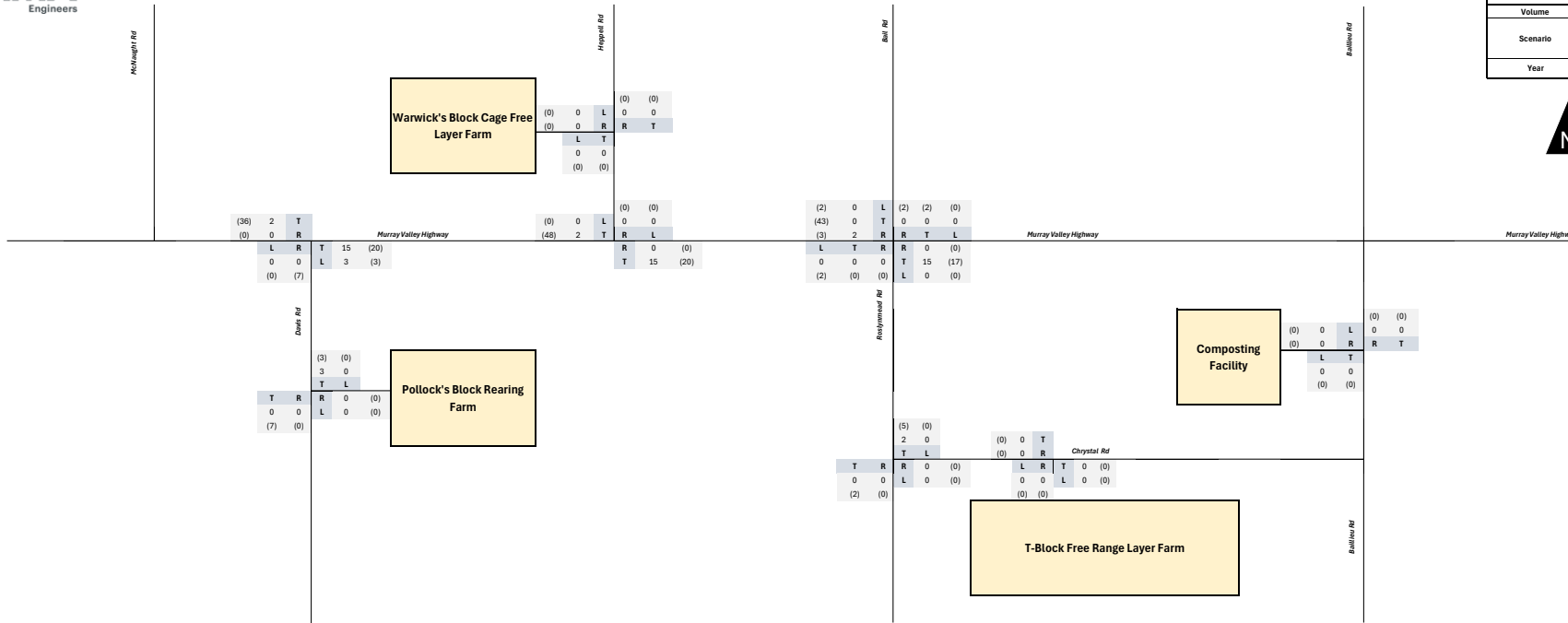

PEAK HOUR VOLUME SUMMARY HEAVY VEHICLES	
Volume	AM (PM)
Scenario	Background (Development Peak 2)
Year	2042

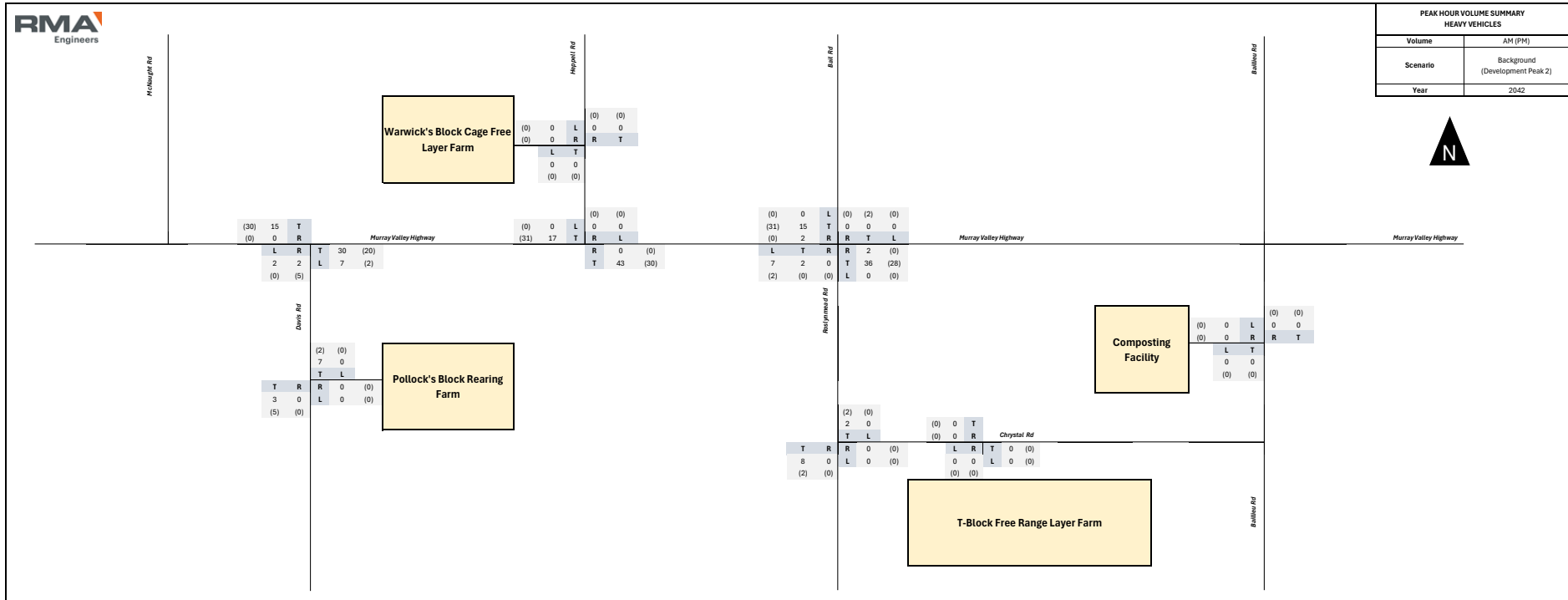

TRAFFIC VOLUME SUMMARY	
HEAVY VEHICLES	
Volume	Daily
Scenario	Background
Year	2042

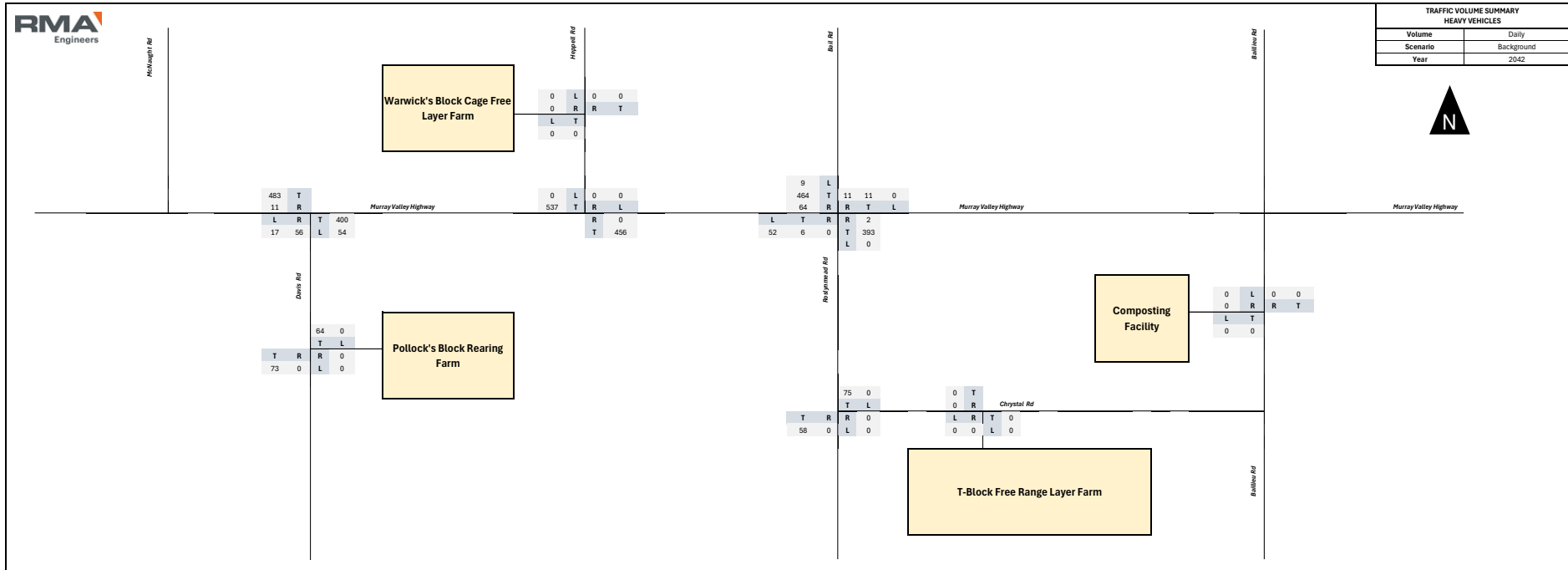

PEAK HOUR VOLUME SUMMARY TOTAL VEHICLES	
Volume	AM (PM)
Scenario	Background (Network Peak)
Year	2052

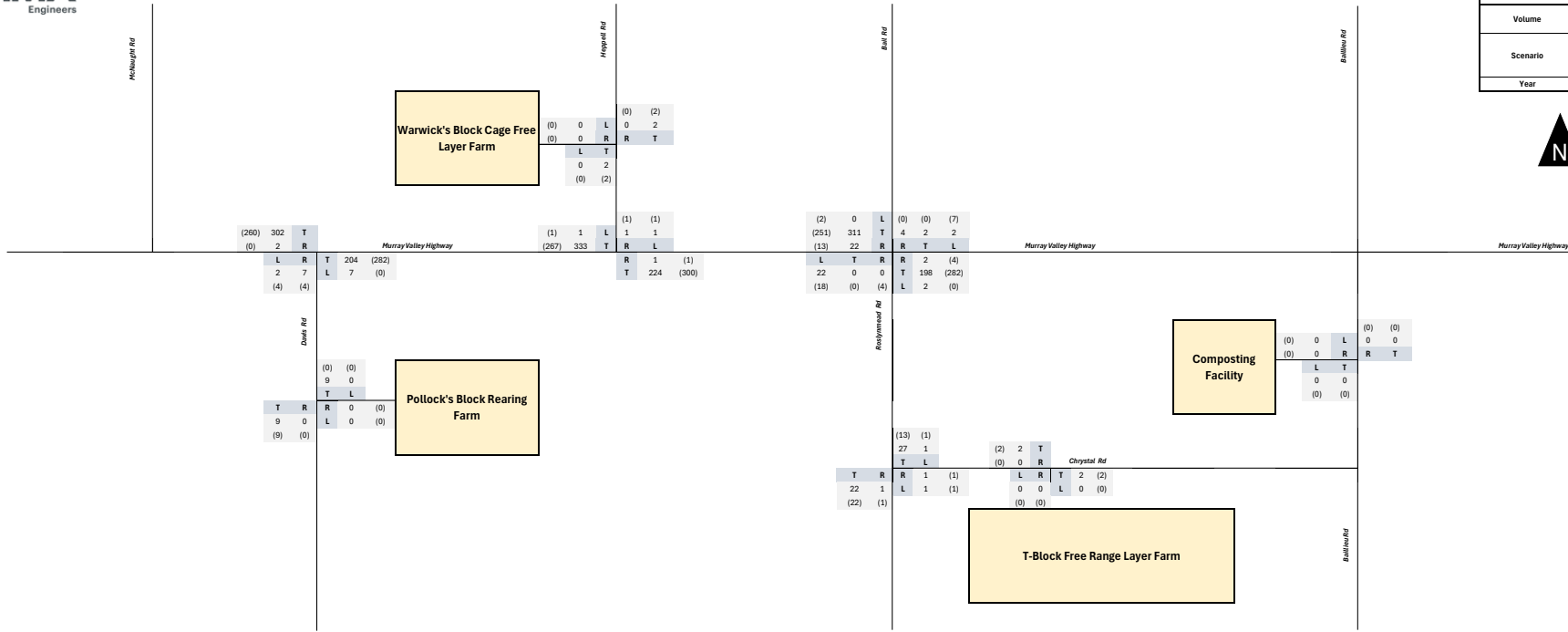

PEAK HOUR VOLUME SUMMARY TOTAL VEHICLES	
Volume	AM (PM)
Scenario	Background (Development Peak 1)
Year	2052

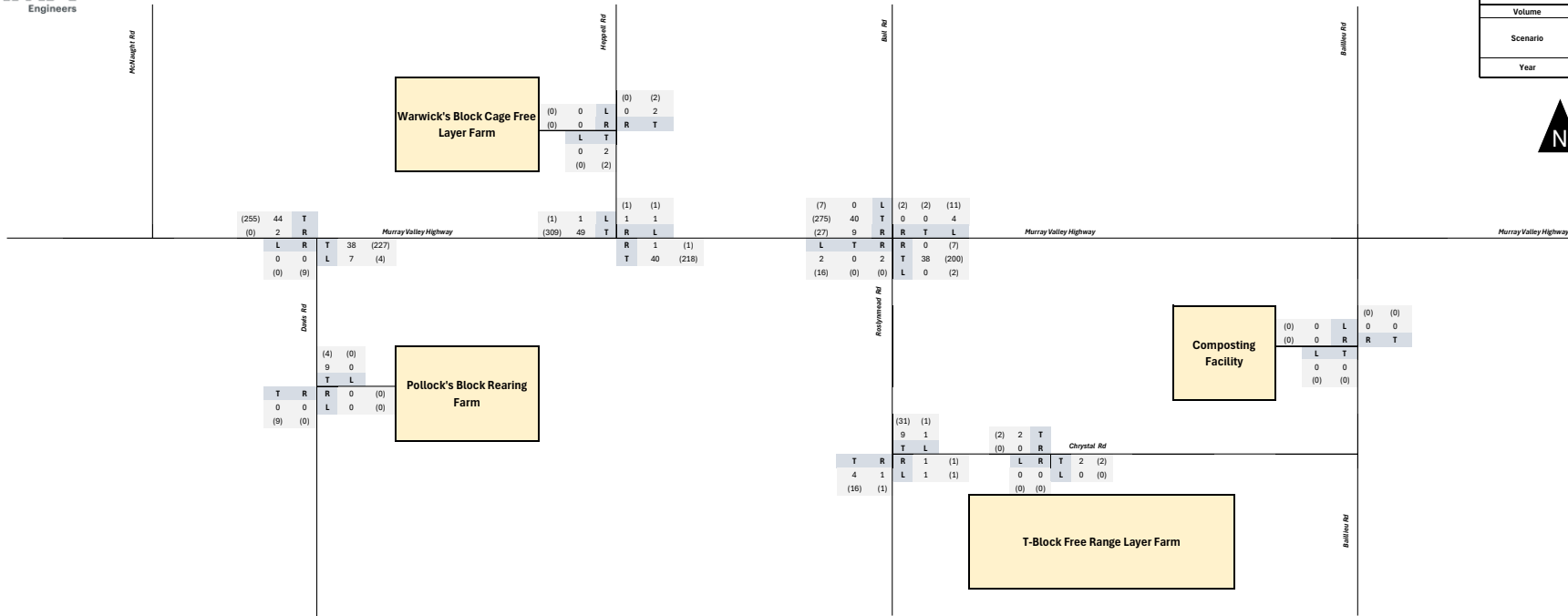

PEAK HOUR VOLUME SUMMARY	
TOTAL VEHICLES	
Volume	AM (PM)
Scenario	Background (Development Peak 2)
Year	2052

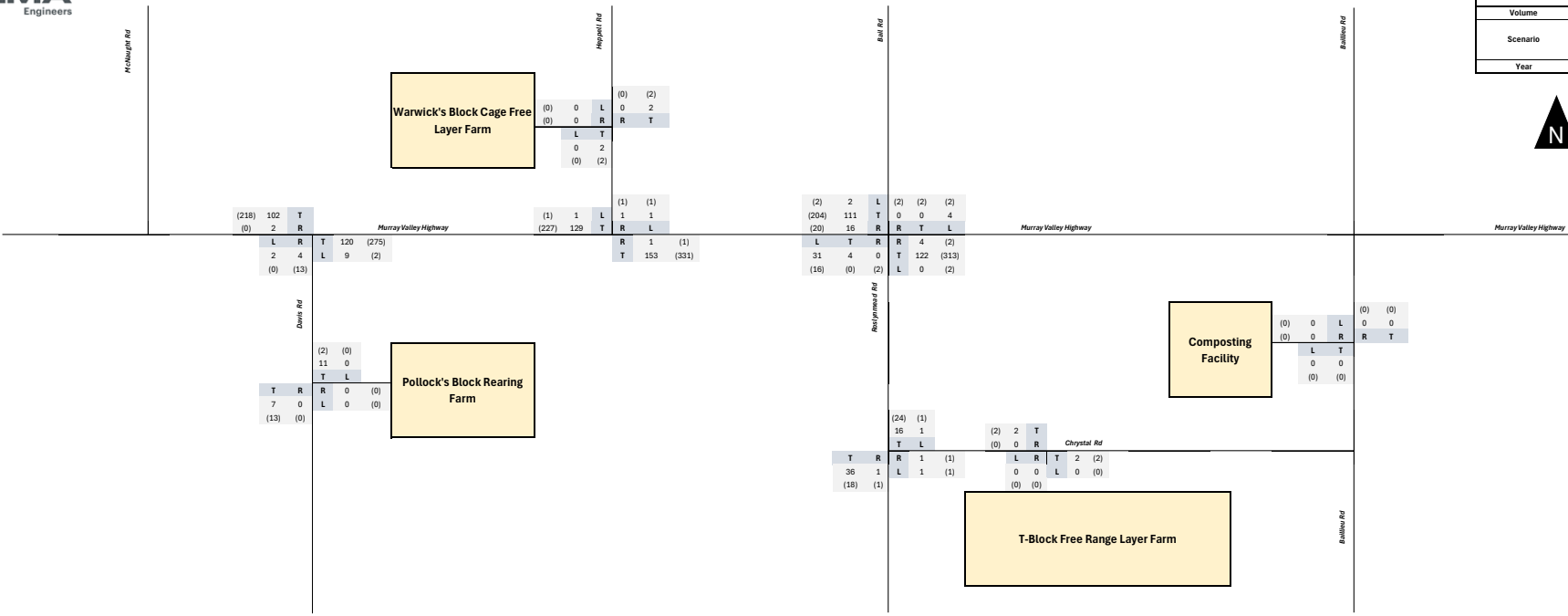

TRAFFIC VOLUME SUMMARY	
TOTAL VEHICLES	
Volume	Daily
Scenario	Background
Year	2052

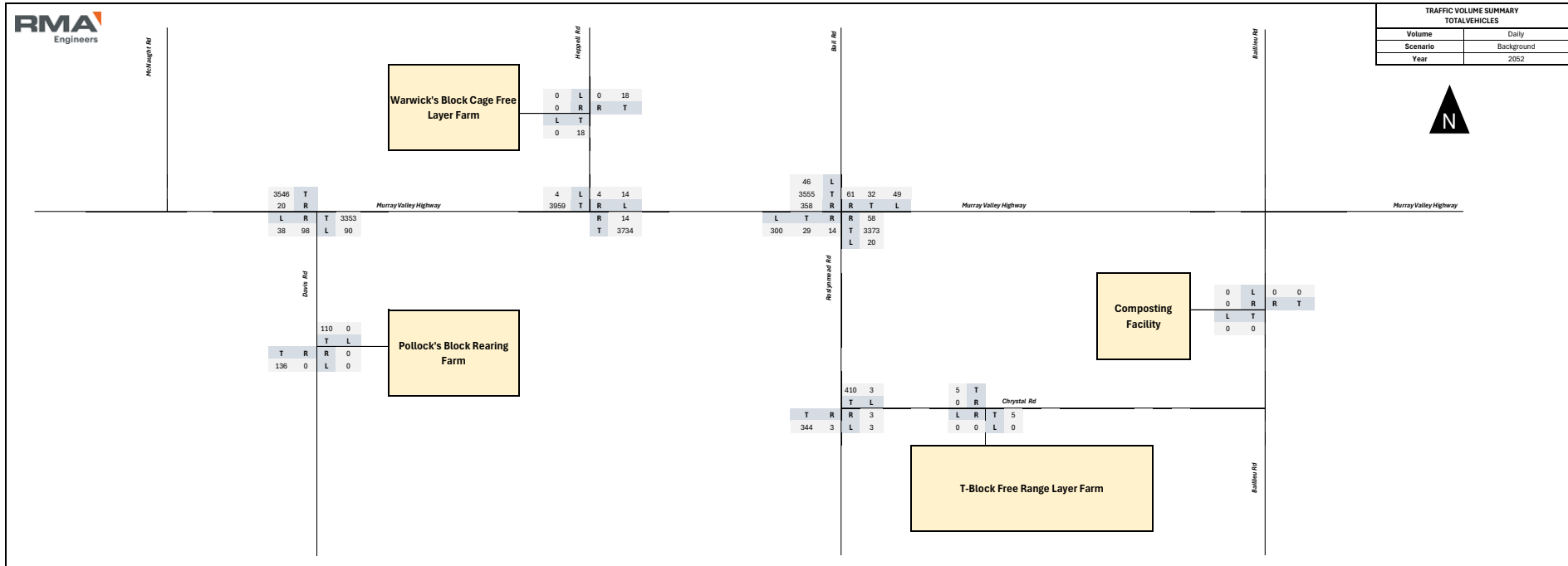

PEAK HOUR VOLUME SUMMARY LIGHT VEHICLES	
Volume	AM (PM)
Scenario	Background (Network Peak)
Year	2052

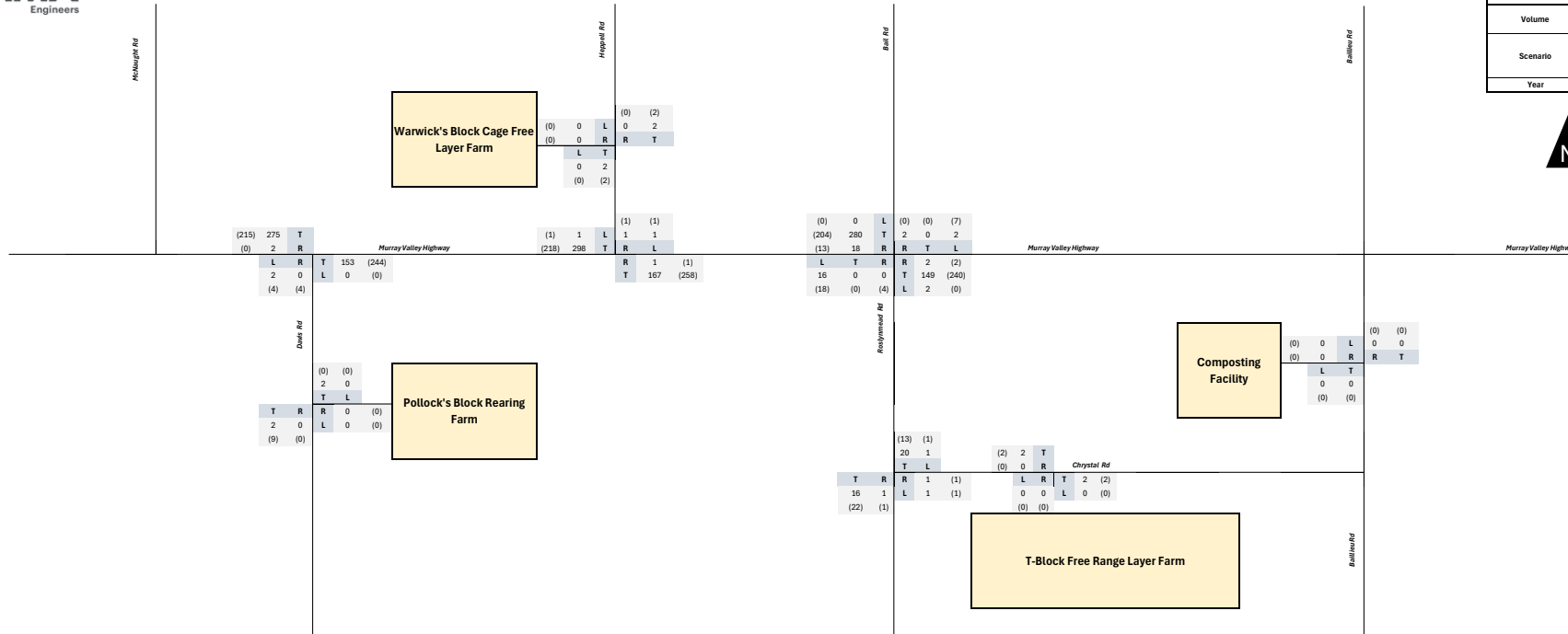

PEAK HOUR VOLUME SUMMARY LIGHT VEHICLES	
Volume	AM (PM)
Scenario	Background (Development Peak 1)
Year	2052

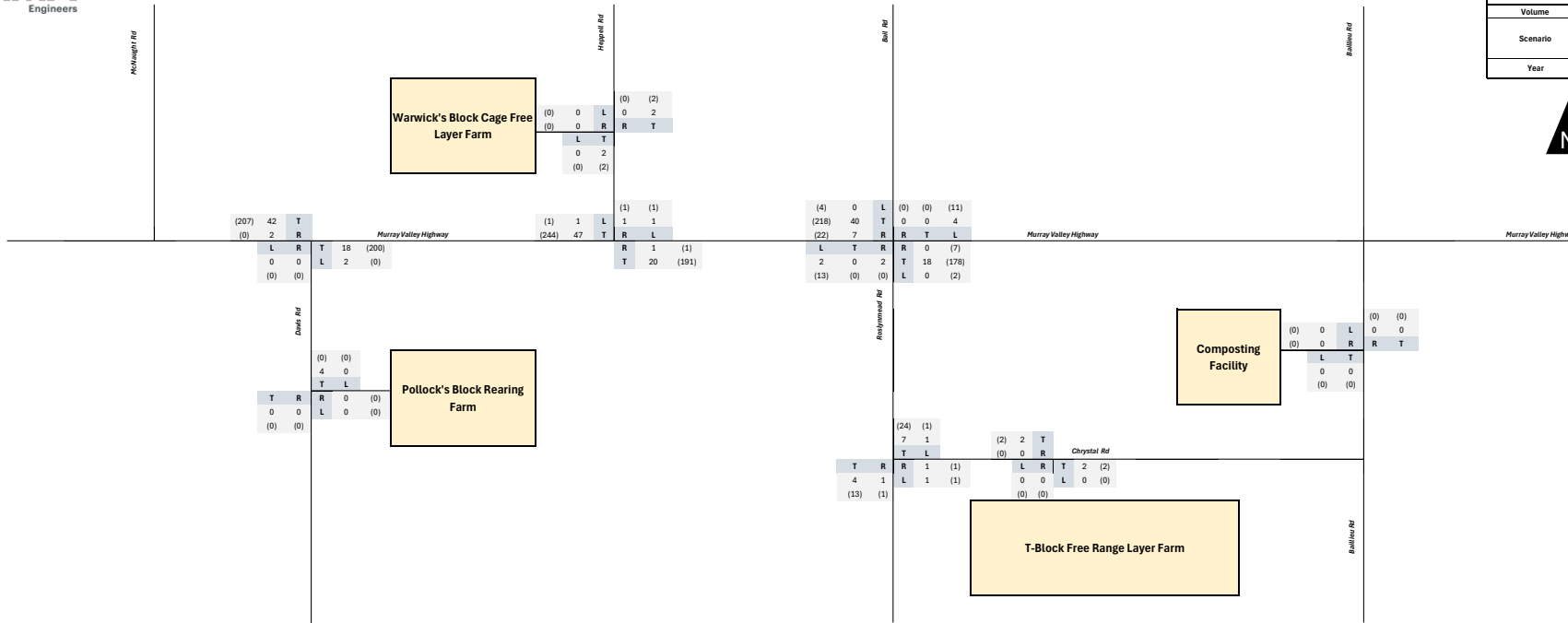

PEAK HOUR VOLUME SUMMARY LIGHT VEHICLES	
Volume	AM (PM)
Scenario	Background (Development Peak 2)
Year	2052

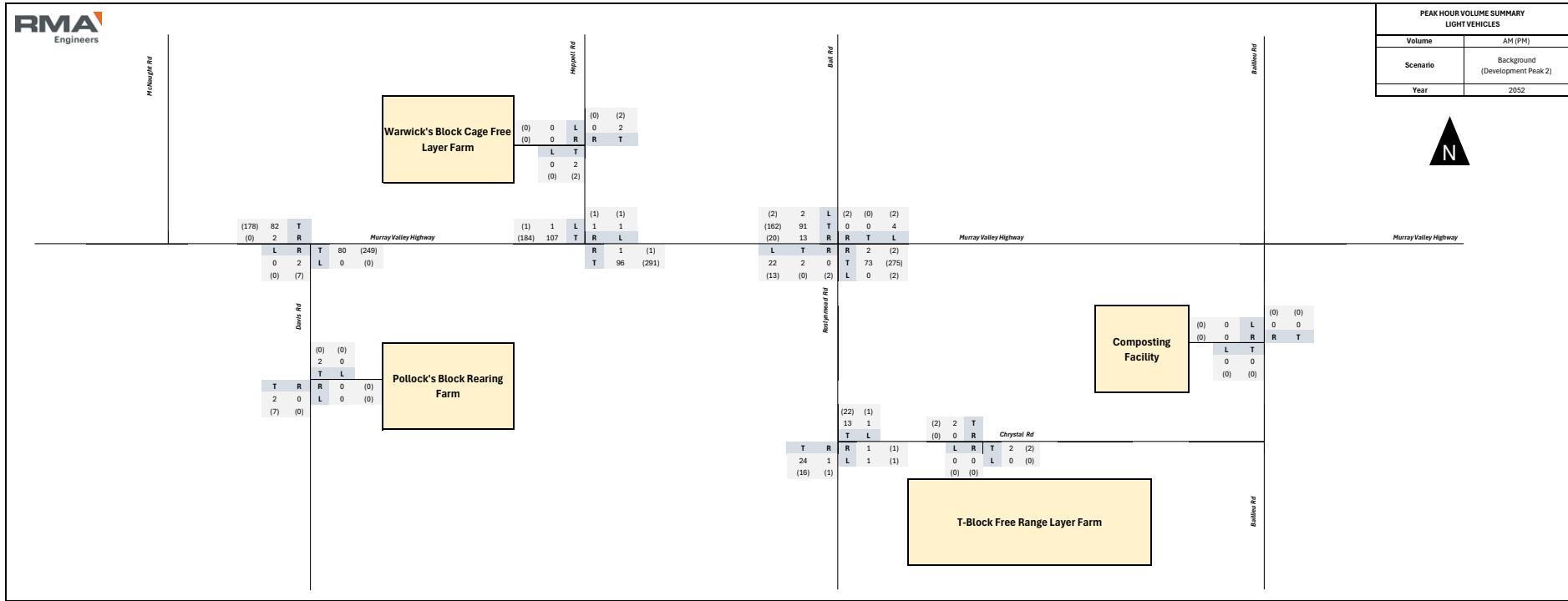

TRAFFIC VOLUME SUMMARY	
LIGHT VEHICLES	
Volume	Daily
Scenario	Background
Year	2052

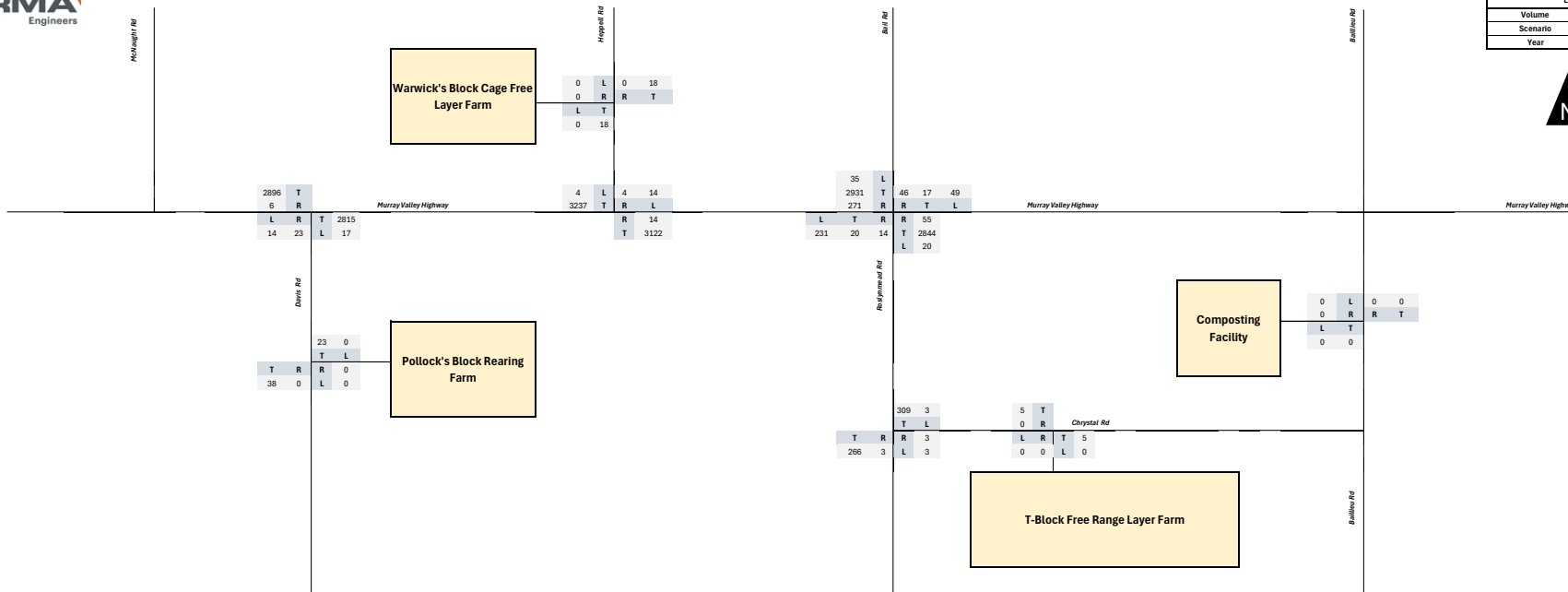

PEAK HOUR VOLUME SUMMARY HEAVY VEHICLES	
Volume	AM (PM)
Scenario	Background (Network Peak)
Year	2052

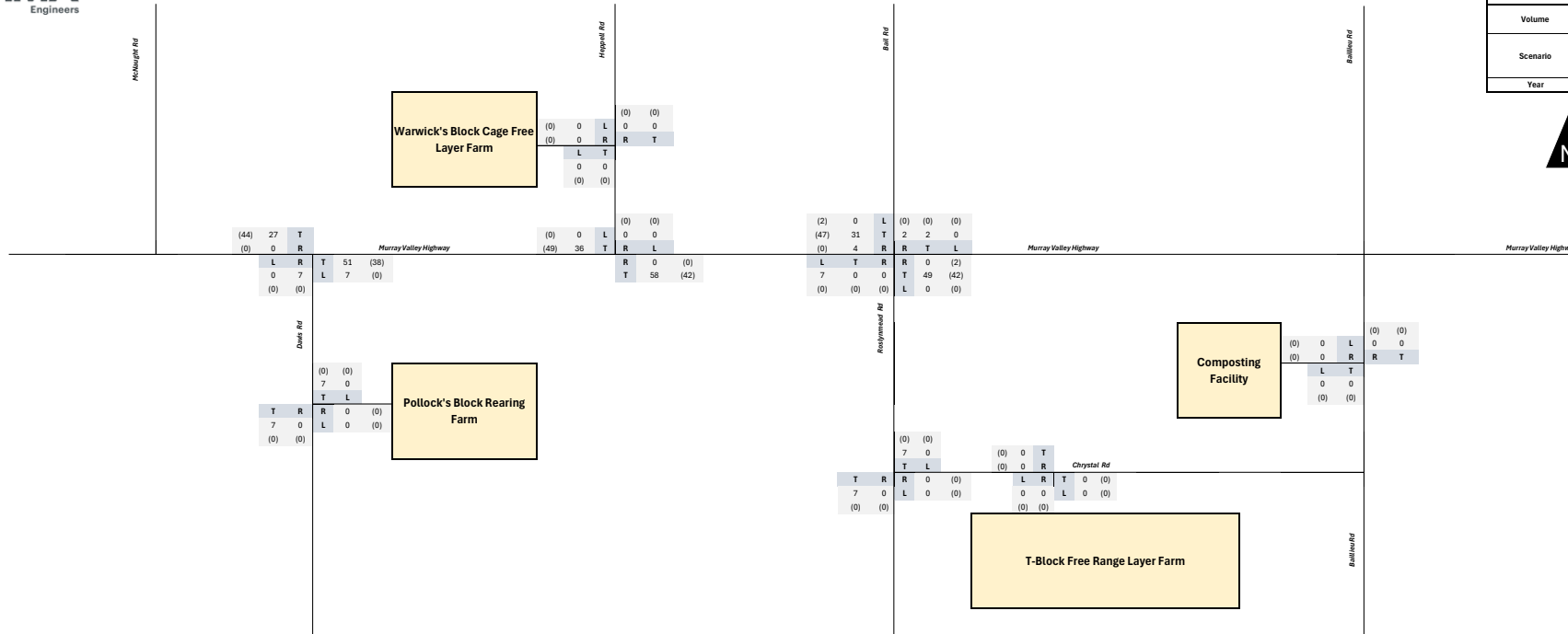

PEAK HOUR VOLUME SUMMARY HEAVY VEHICLES	
Volume	AM (PM)
Scenario	Background (Development Peak 1)
Year	2052

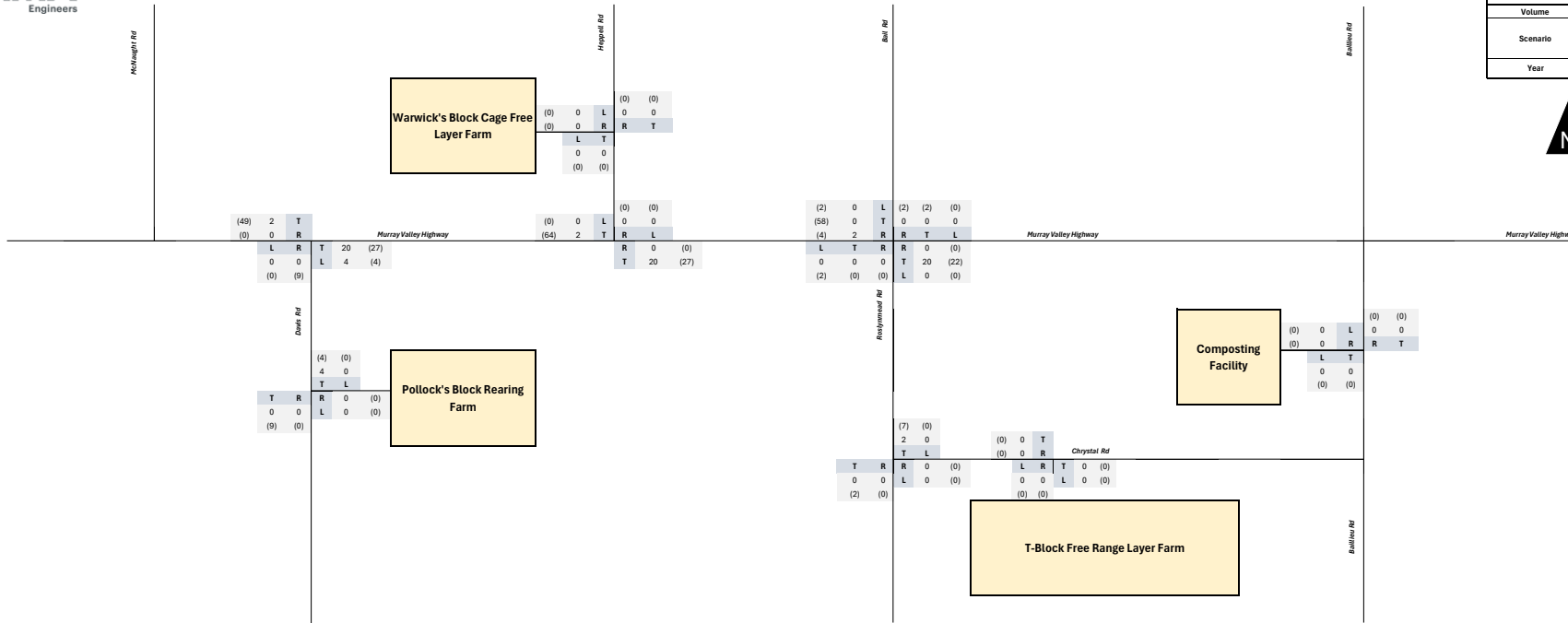

PEAK HOUR VOLUME SUMMARY HEAVY VEHICLES	
Volume	AM (PM)
Scenario	Background (Development Peak 2)
Year	2052

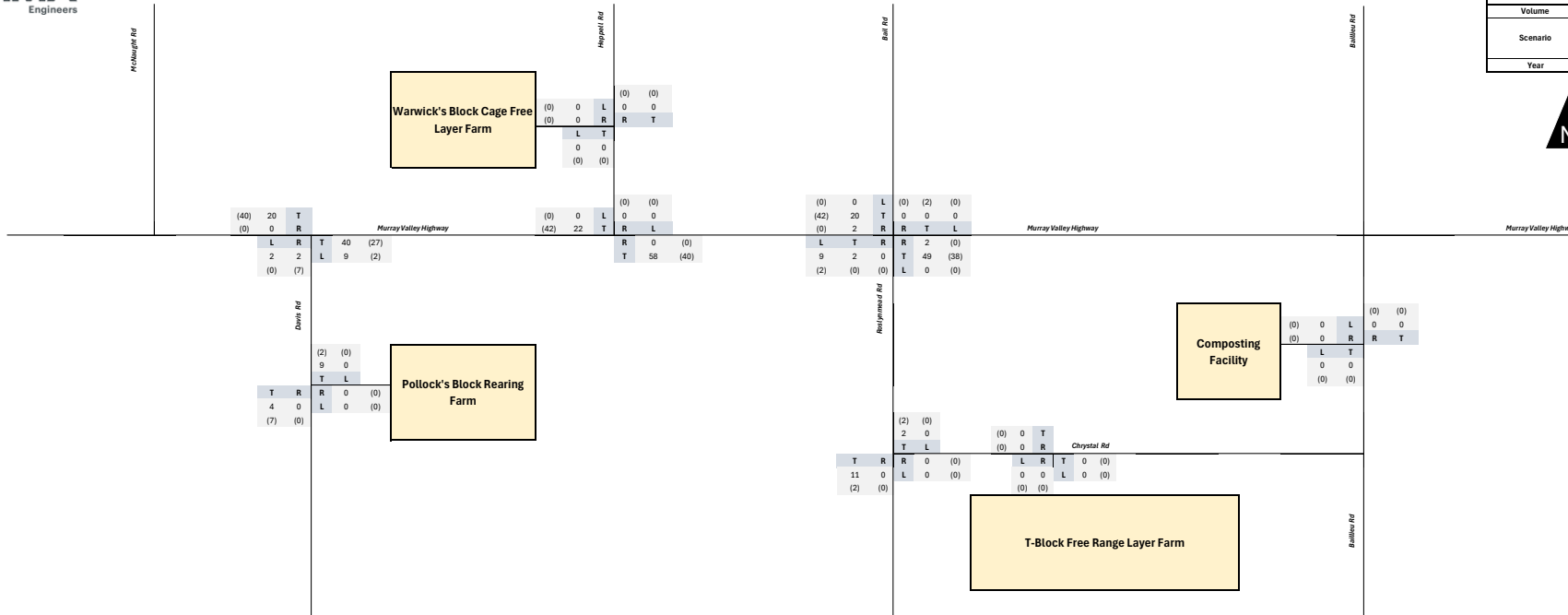

TRAFFIC VOLUME SUMMARY	
HEAVY VEHICLES	
Volume	Daily
Scenario	Background
Year	2052

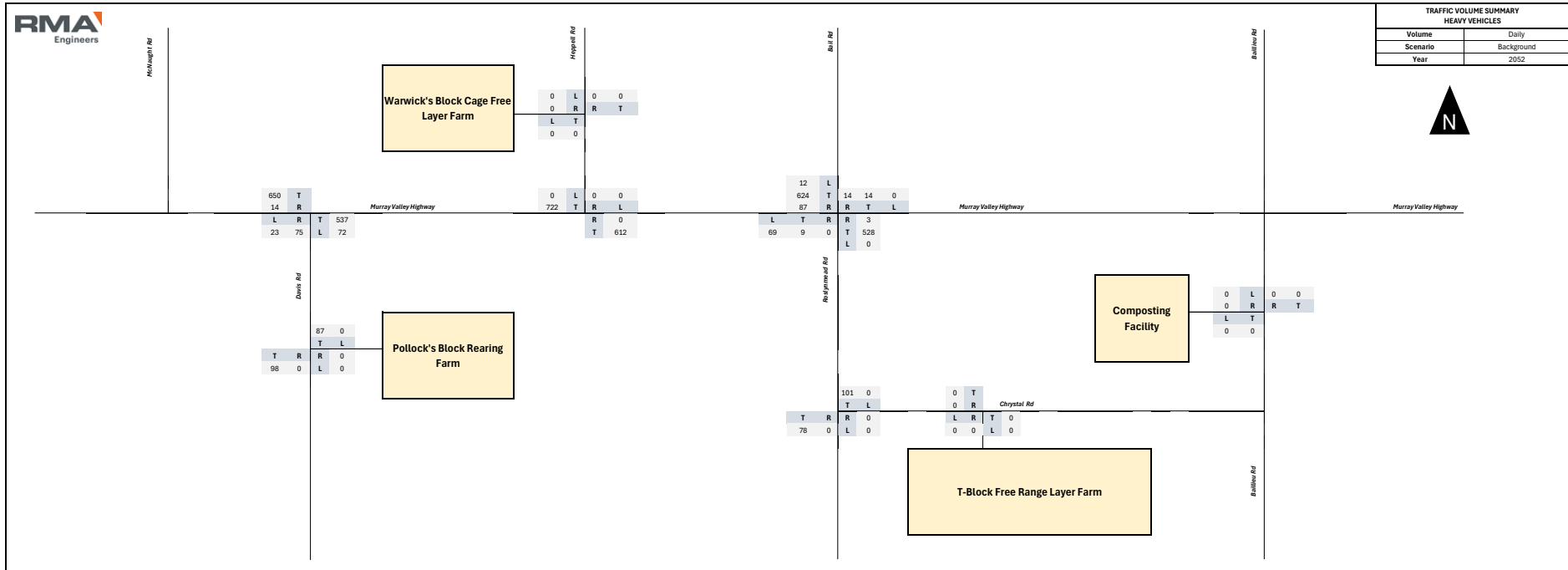

## Appendix E Development traffic volumes

PEAK HOUR VOLUME SUMMARY TOTAL VEHICLES	
Volume	AM (PM)
Scenario	Development (Ultimate) Pollocks Rearing Farm (Network Peak)
Year	2040

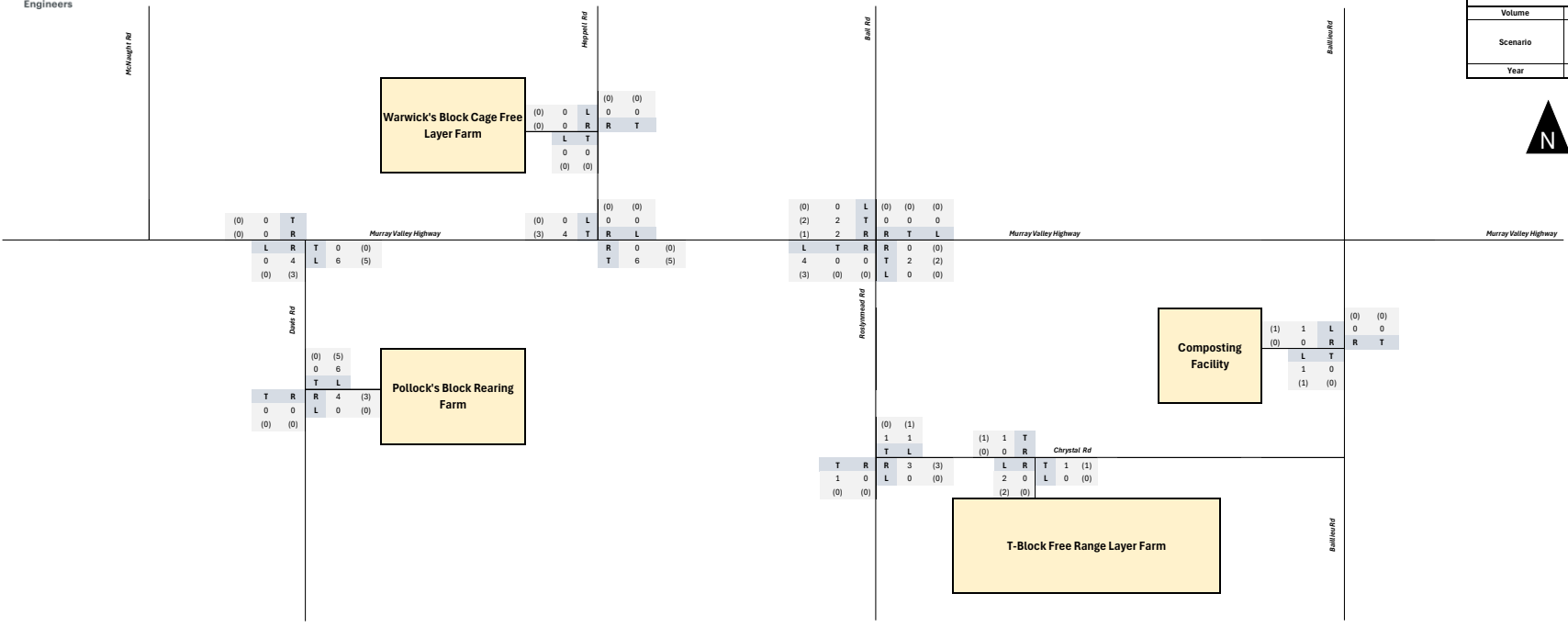

McNaught Rd

Hayslett Rd

Balfour Rd

Balfour Rd

Duns Rd

Pollock's Rd

Balfour Rd

**Warwick's Block Cage Free Layer Farm**

**Pollock's Block Rearing Farm**

**Composting Facility**

**T-Block Free Range Layer Farm**

Murray Valley Highway

Murray Valley Highway

Murray Valley Highway

Chrystal Rd

(0)	0	T		
(0)	0	R		
L	R	T	0	(0)
0	4	L	6	(5)
(0)	(3)			

(0)	0	L		(0)
(0)	0	R		T
L	T			
0	0			
(0)	(0)			

(0)	0	L	(0)	(0)	(0)
(2)	2	T	0	0	0
(1)	2	R	R	T	L
L	T	R	0	(0)	
4	0	0	T	2	(2)
(3)	(0)	(0)	L	0	(0)

(0)	(5)		
0	6		
T	L		
T	R	4	(3)
0	0	L	0
(0)	(0)		

(0)	(1)		
1	1		
T	L		
T	R	3	(3)
1	0	L	0
(0)	(0)		

(1)	1	T	
(0)	0	R	
L	R	T	1
2	0	L	0
(2)	(0)		

(1)	1	L	(0)	(0)
(0)	0	R	0	0
L	T			
1	0			
(1)	(0)			

PEAK HOUR VOLUME SUMMARY TOTAL VEHICLES	
Volume	AM (PM)
Scenario	Development (Ultimate) Pollocks Rearing Farm (Development Peak 1)
Year	2040

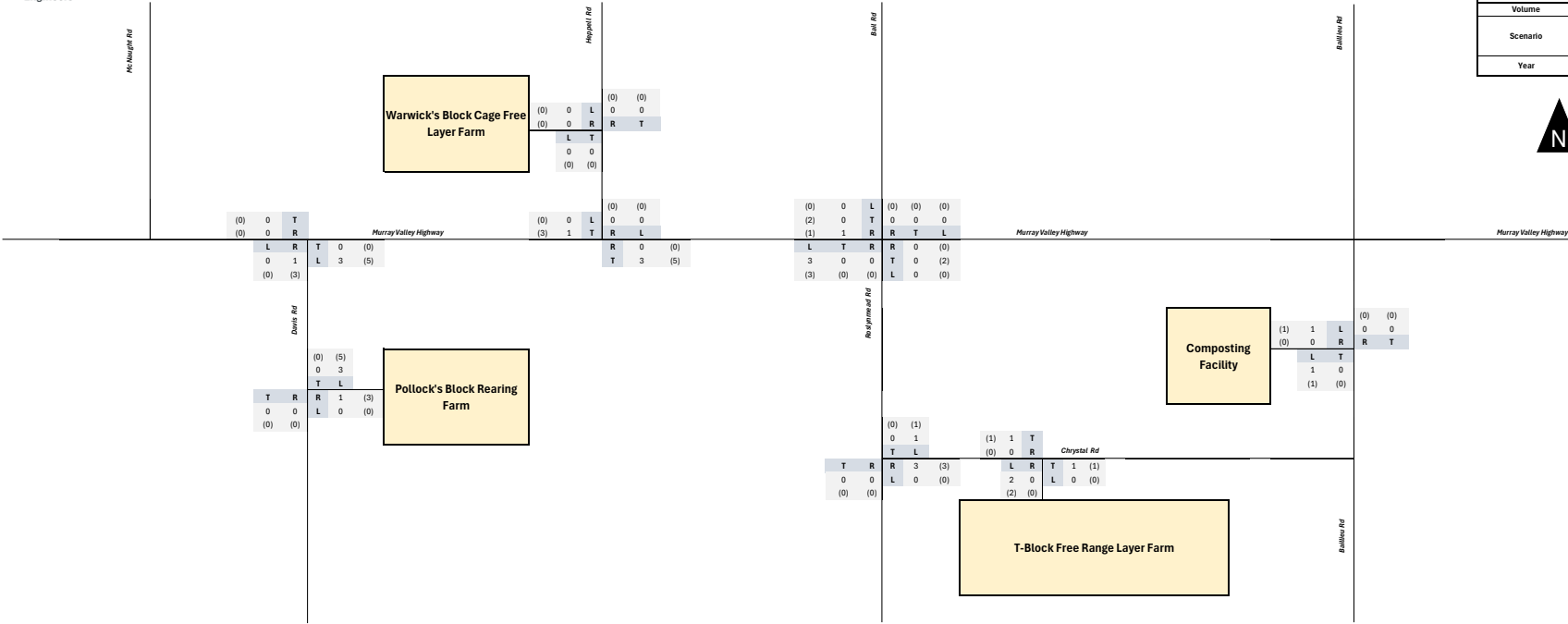

PEAK HOUR VOLUME SUMMARY TOTAL VEHICLES	
Volume	AM (PM)
Scenario	Development (Ultimate) Pollocks Rearing Farm (Development Peak 2)
Year	2040

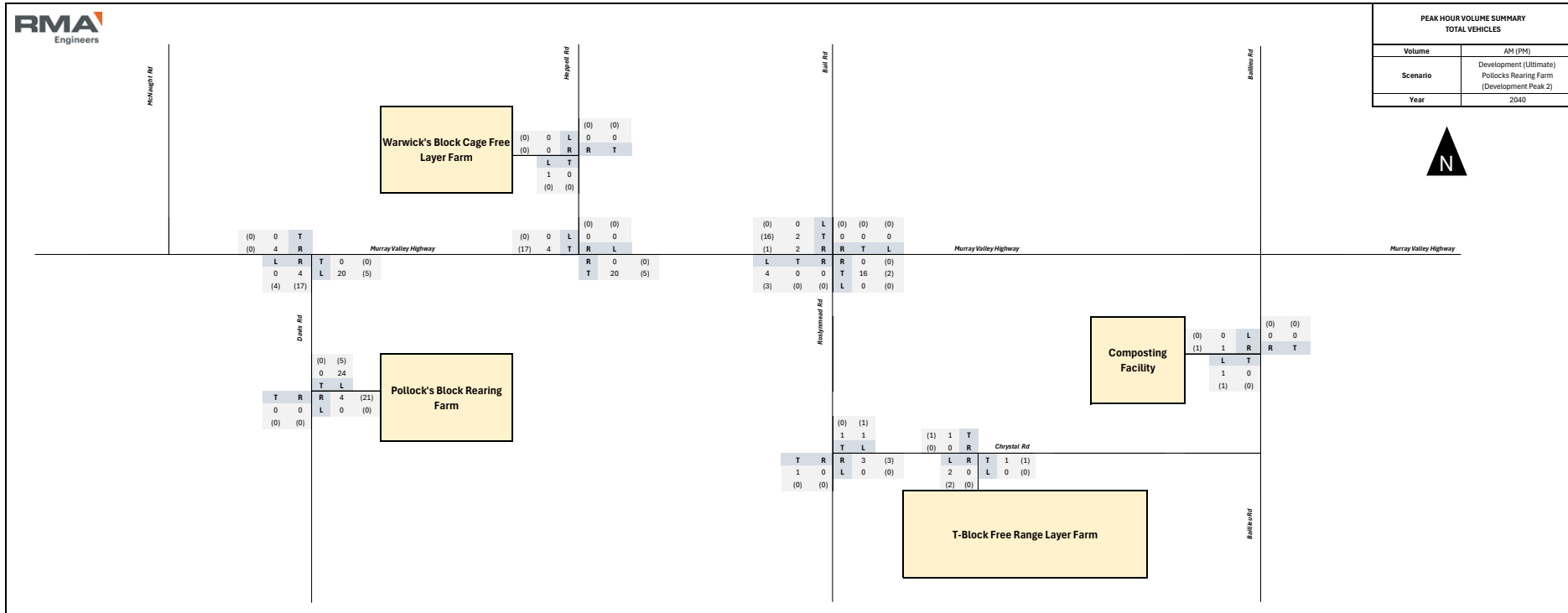

TRAFFIC VOLUME SUMMARY TOTAL VEHICLES	
Volume	Estimated Maximum Daily
Scenario	Development (Ultimate) Pollocks Rearing Farm
Year	2040

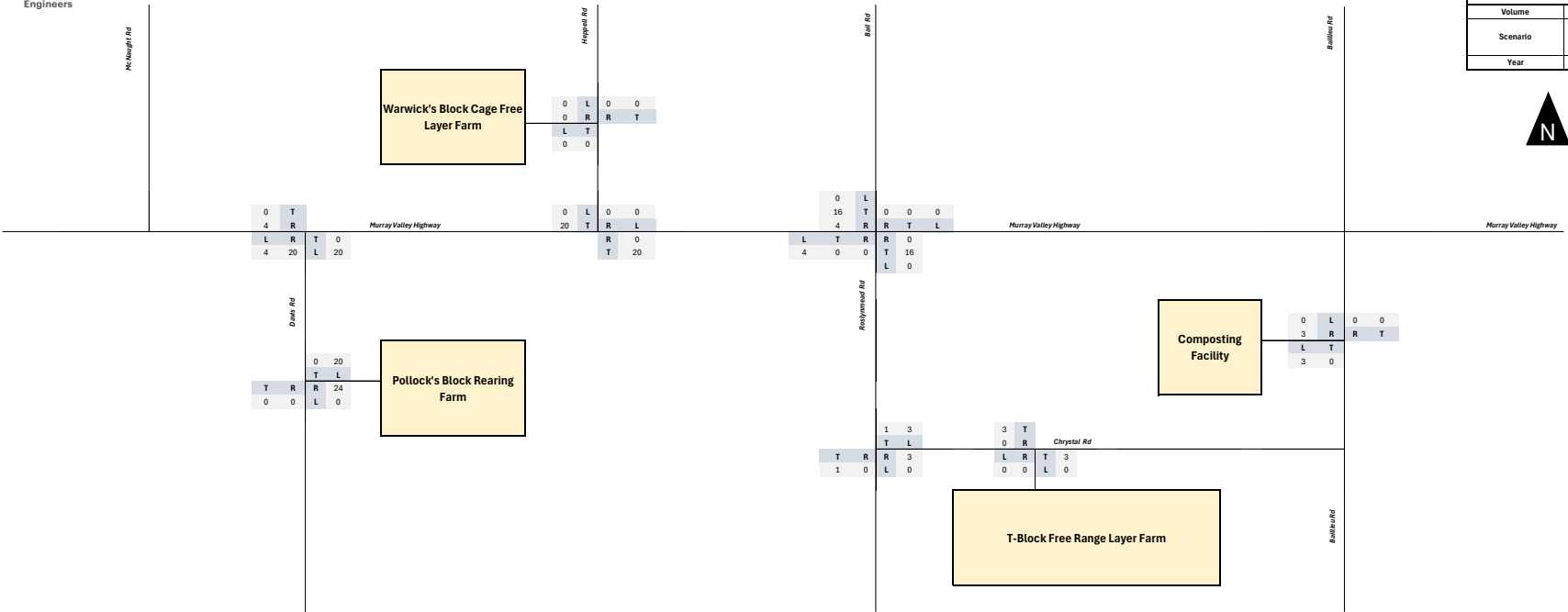

**Warwick's Block Cage Free Layer Farm**

**Pollock's Block Rearing Farm**

**Composting Facility**

**T-Block Free Range Layer Farm**

PEAK HOUR VOLUME SUMMARY LIGHT VEHICLES	
Volume	AM (PM)
Scenario	Development (Ultimate) Potlocks Rearing Farm (Network Peak)
Year	2040

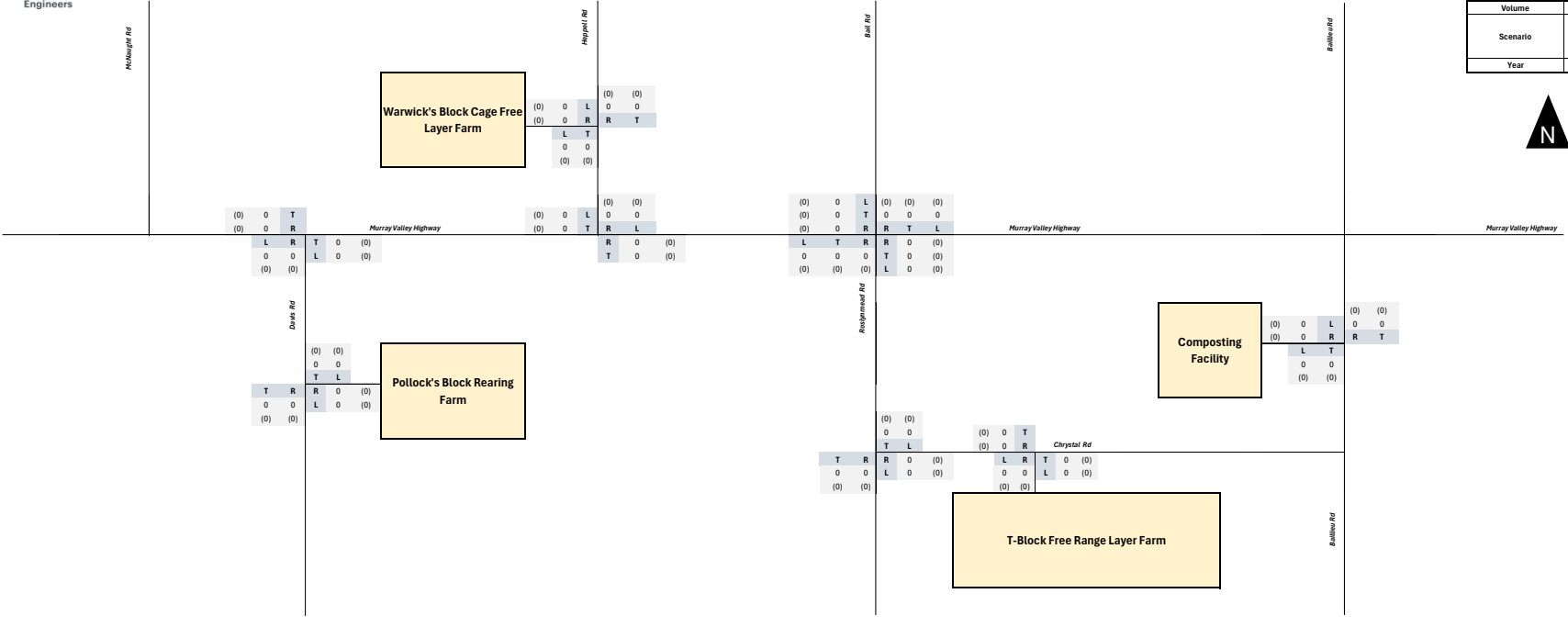

PEAK HOUR VOLUME SUMMARY LIGHT VEHICLES	
Volume	AM (PM)
Scenario	Development (Ultimate) Pollocks Rearing Farm (Development Peak 1)
Year	2040

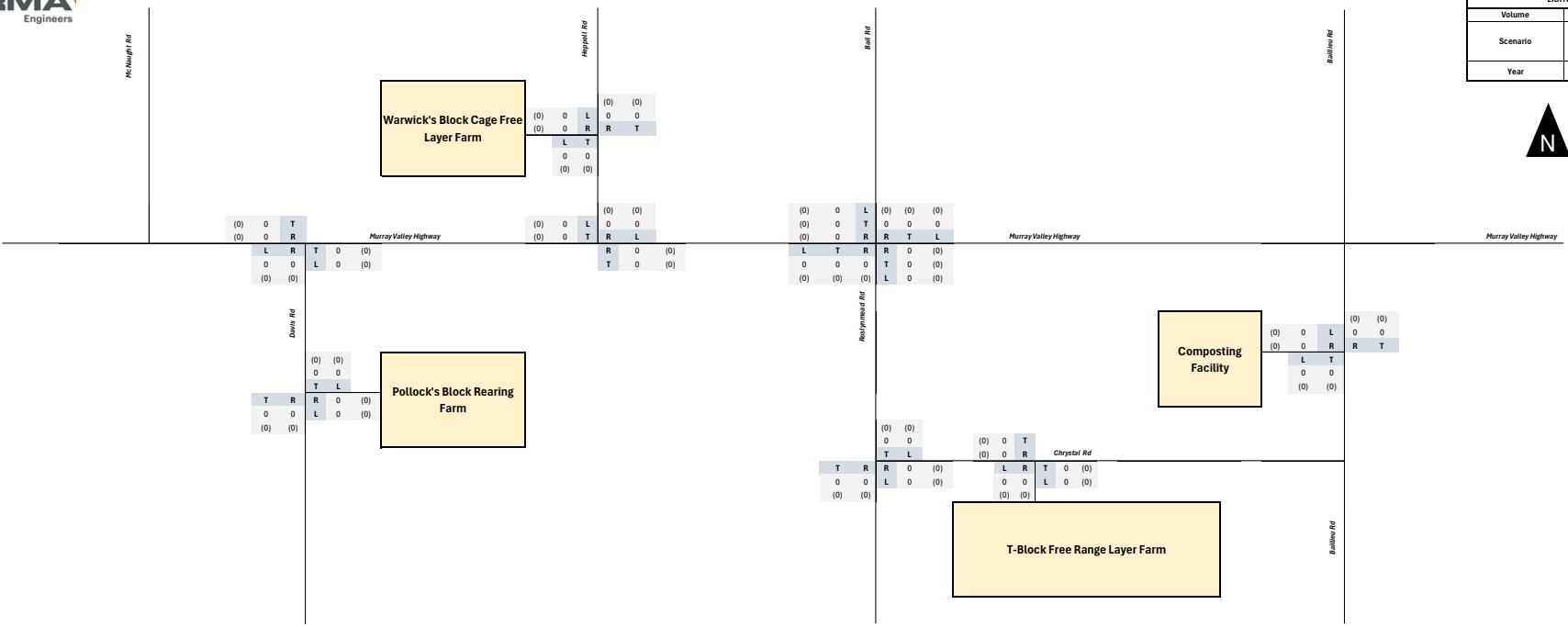

PEAK HOUR VOLUME SUMMARY LIGHT VEHICLES	
Volume	AM (PM)
Scenario	Development (Ultimate) Pollocks Rearing Farm (Development Peak 2)
Year	2040

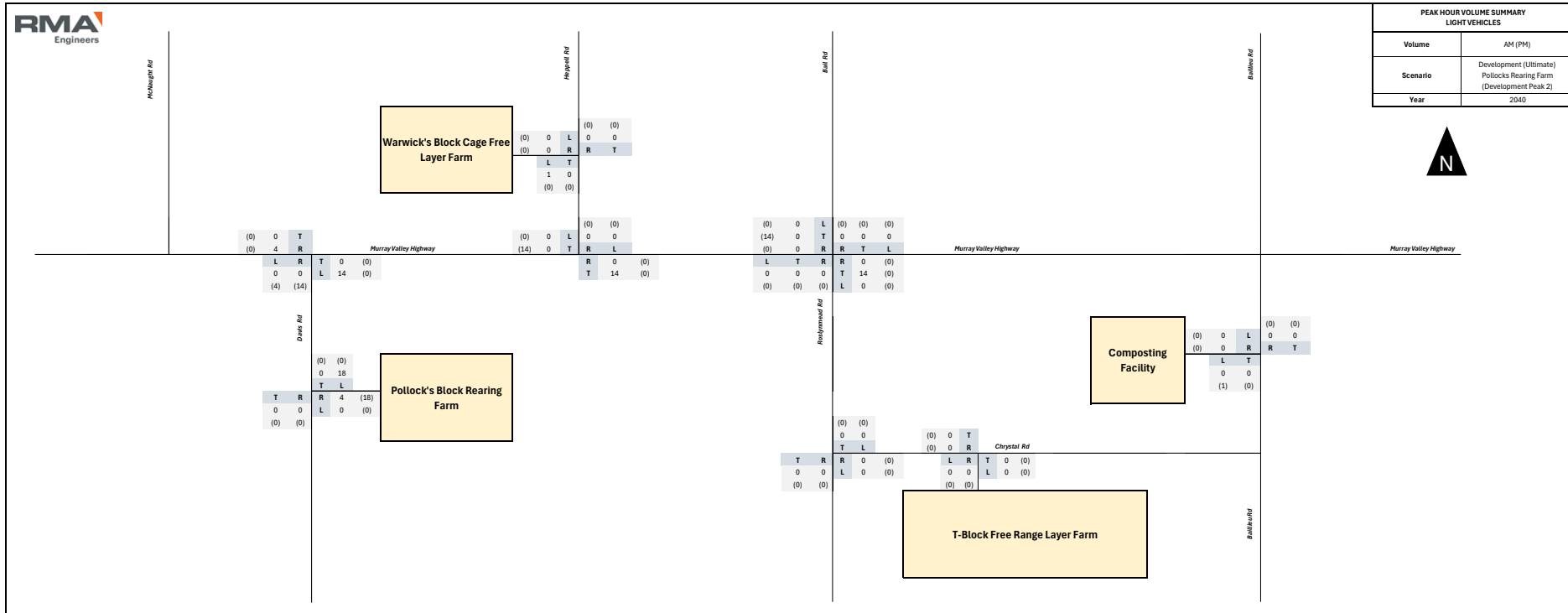

TRAFFIC VOLUME SUMMARY LIGHT VEHICLES	
Volume	Estimated Maximum Daily
Scenario	Development (Ultimate) Pollocks Rearing Farm
Year	2040

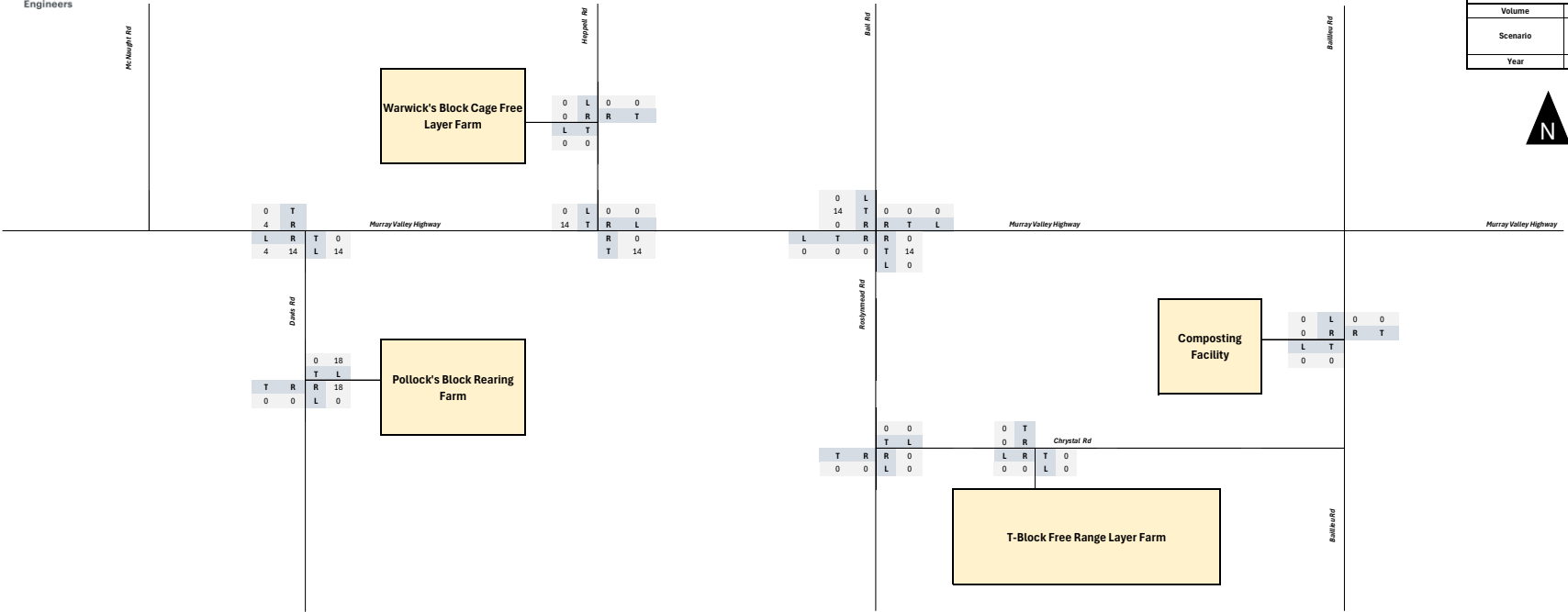

PEAK HOUR VOLUME SUMMARY HEAVY VEHICLES	
Volume	AH (PM)
Scenario	Development (Ultimate) Potlocks Rearing Farm (Network Peak)
Year	2040

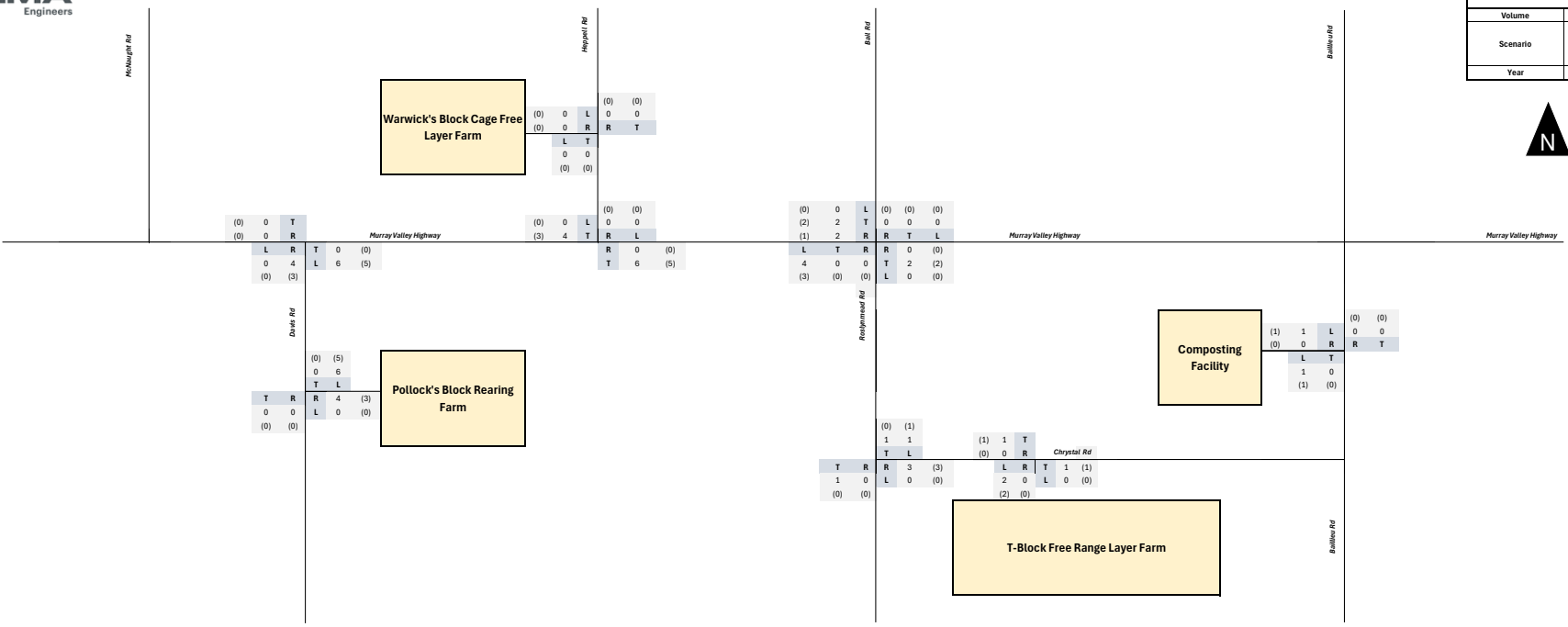

PEAK HOUR VOLUME SUMMARY HEAVY VEHICLES	
Volume	AM (PM)
Scenario	Development (Ultimate) Pollocks Rearing Farm (Development Peak 1)
Year	2040

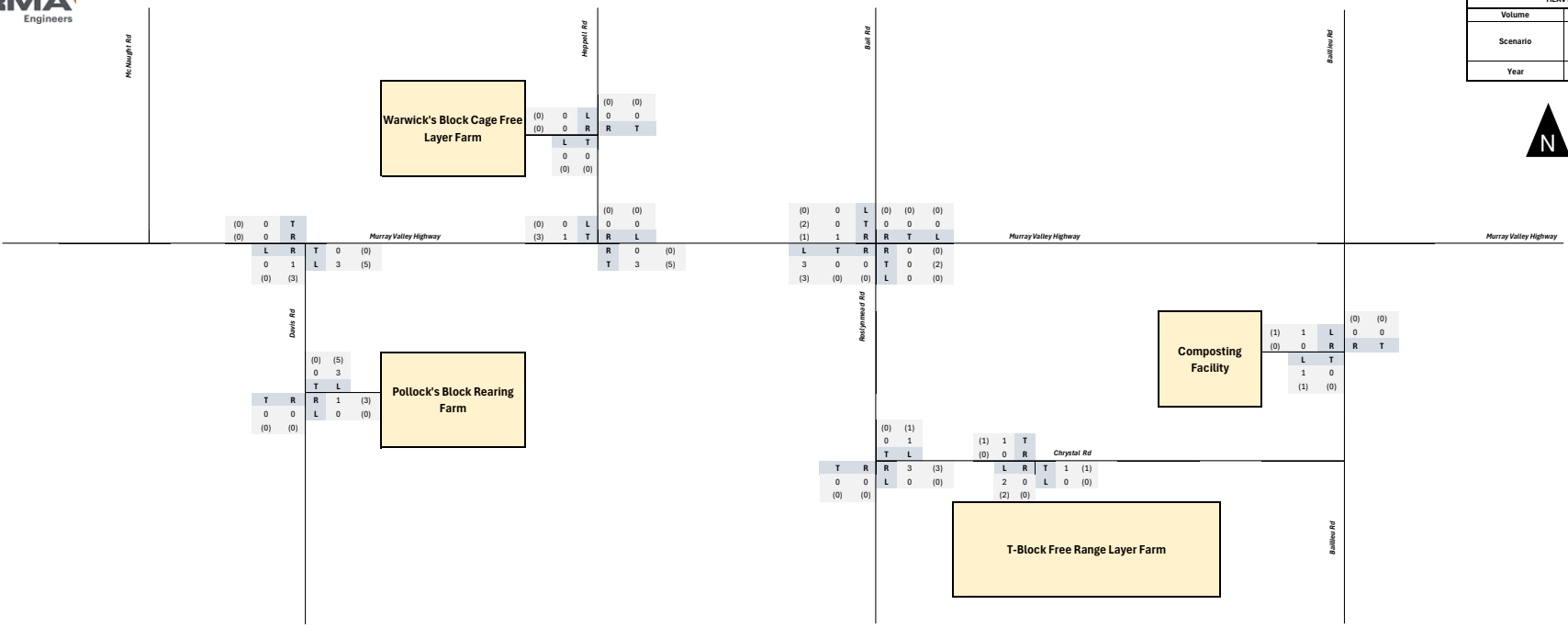

PEAK HOUR VOLUME SUMMARY HEAVY VEHICLES	
Volume	AM (PM)
Scenario	Development (Ultimate) Pollocks Rearing Farm (Development Peak 2)
Year	2040

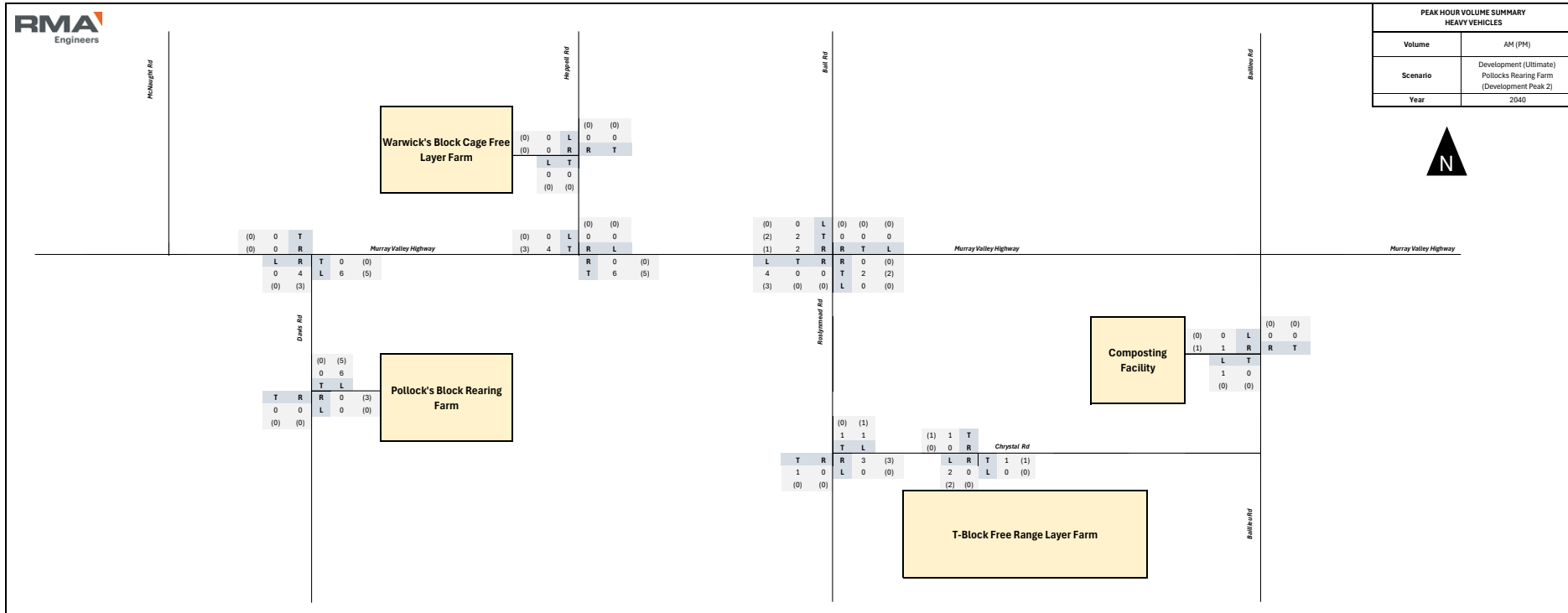

TRAFFIC VOLUME SUMMARY HEAVY VEHICLES	
Volume	Estimated Maximum Daily
Scenario	Development (Ultimate) Pollocks Rearing Farm
Year	2040

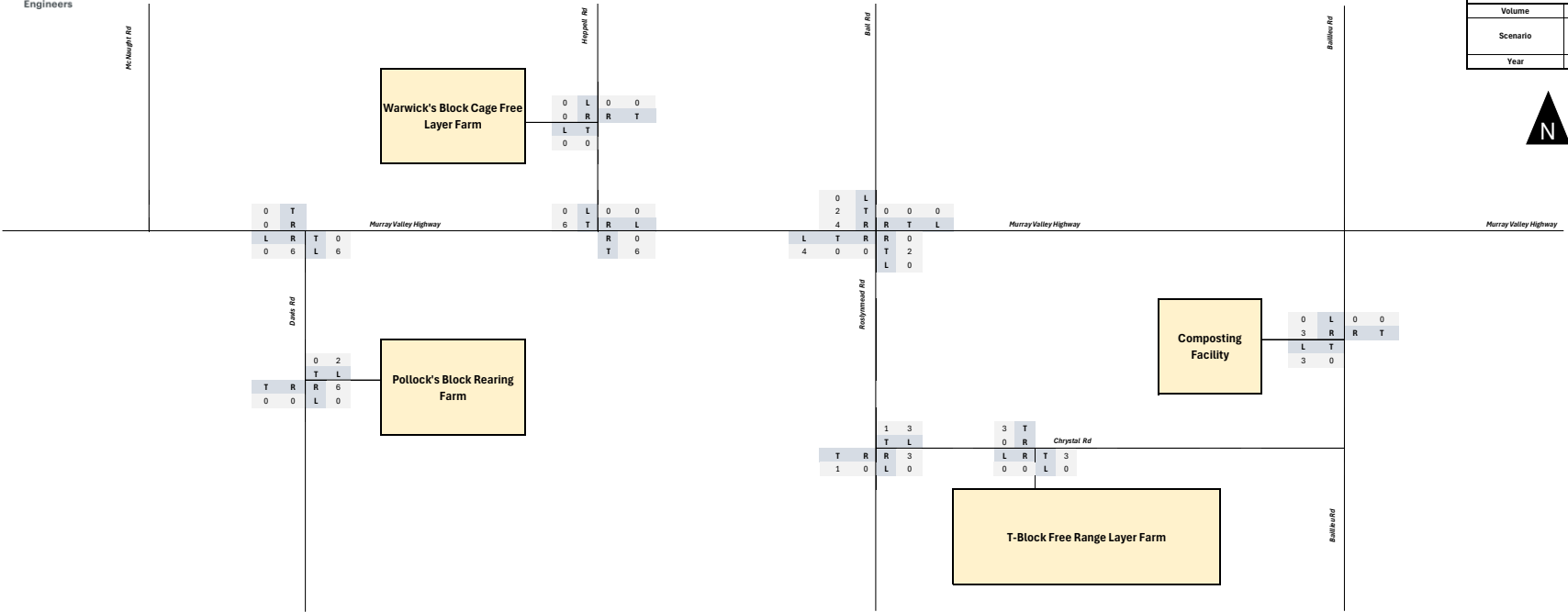

PEAK HOUR VOLUME SUMMARY	
TOTAL VEHICLES	
Volume	AM (PM)
Scenario	Development (Ultimate) Warwick's Block Cage Free Layer Farm (Network Peak)
Year	2040

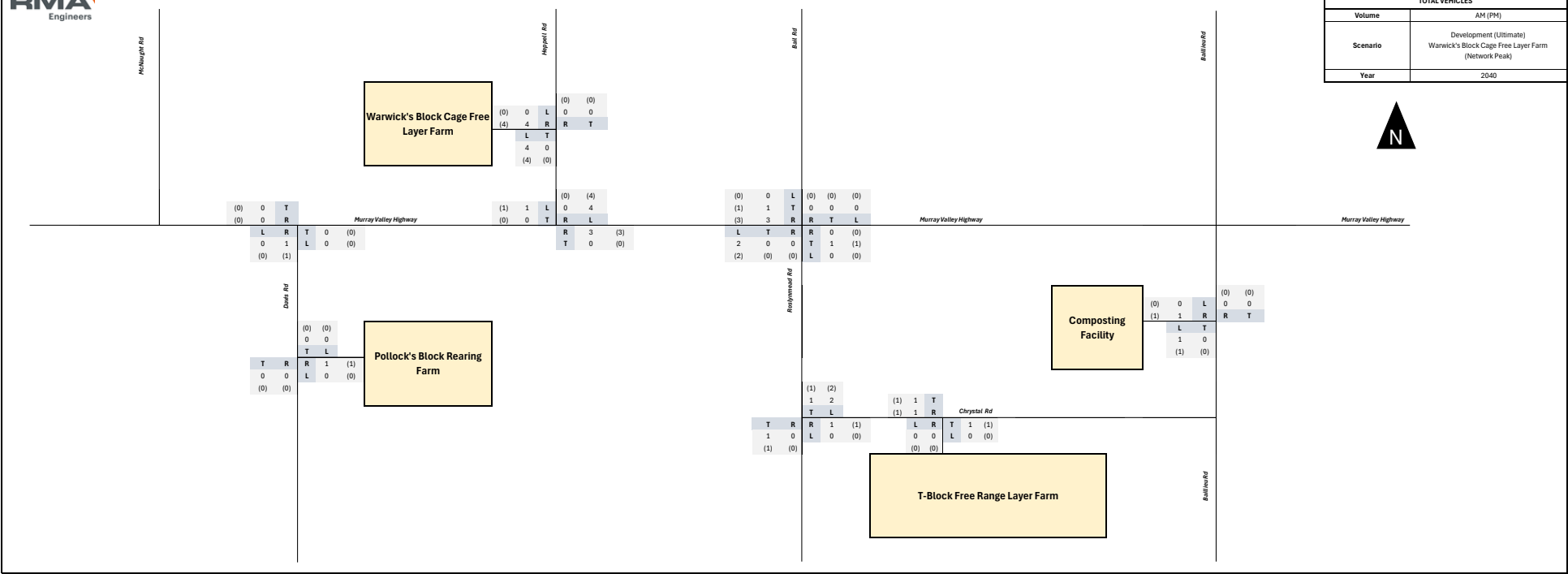

PEAK HOUR VOLUME SUMMARY TOTAL VEHICLES	
Volume	AM (PM)
Scenario	Development (Ultimate) Warwick's Block Cage Free Layer Farm (Development Peak 1)
Year	2040

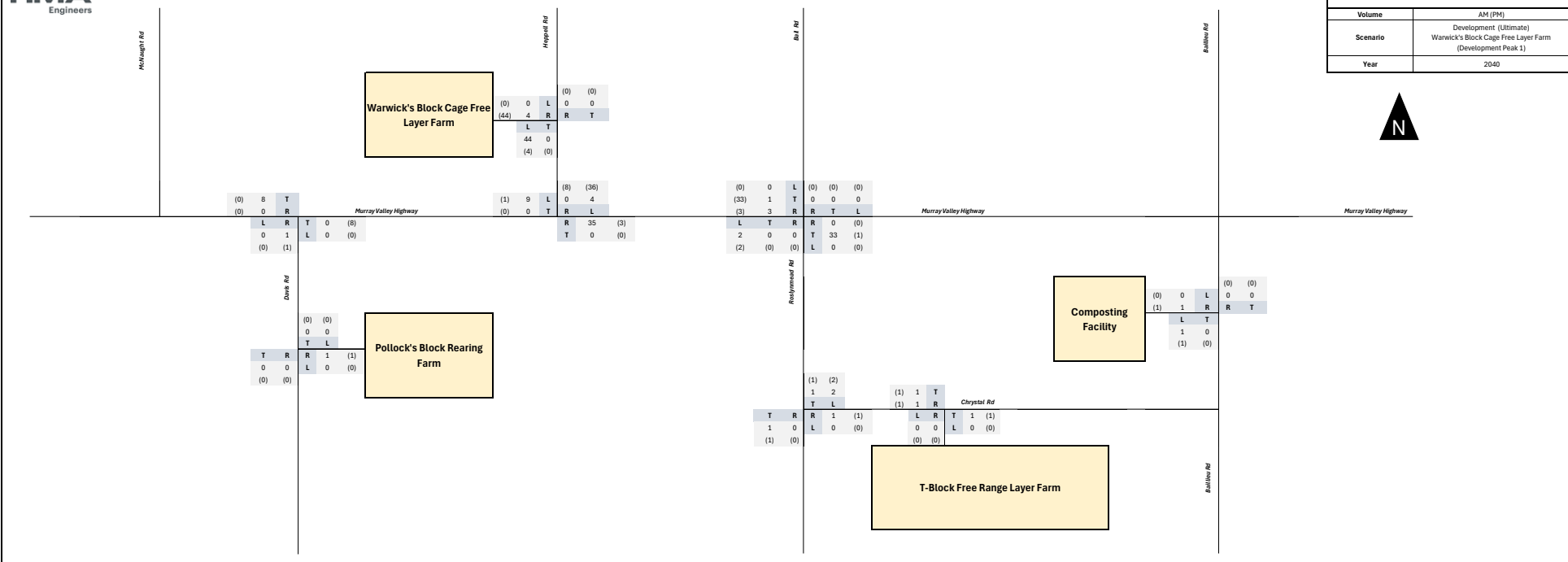

PEAK HOUR VOLUME SUMMARY	
TOTAL VEHICLES	
Volume	AM (PM)
Scenario	Development (Ultimate) Warwick's Block Cage Free Layer Farm (Development Peak 2)
Year	2040

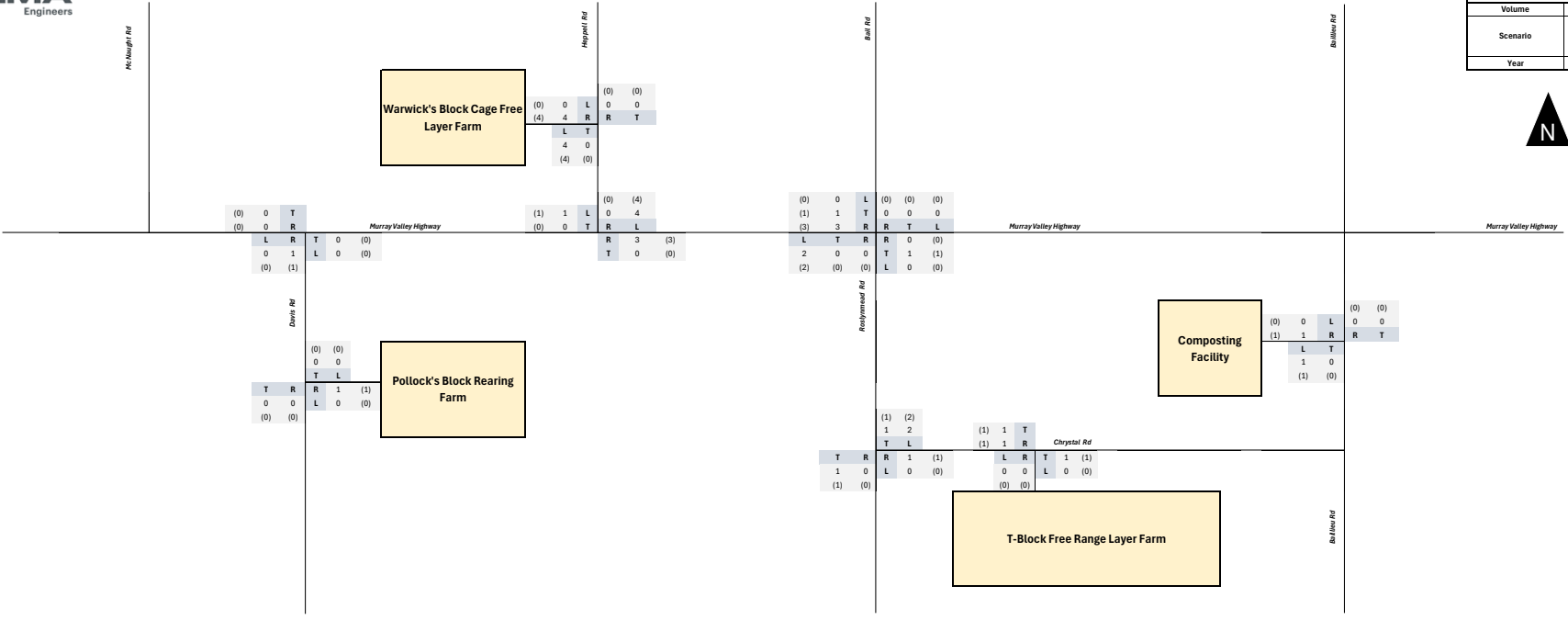

TRAFFIC VOLUME SUMMARY	
TOTAL VEHICLES	
Volume	Estimated Maximum Daily
Scenario	Development (Ultimate) Warwick's Block Cage Free Layer Farm
Year	2040

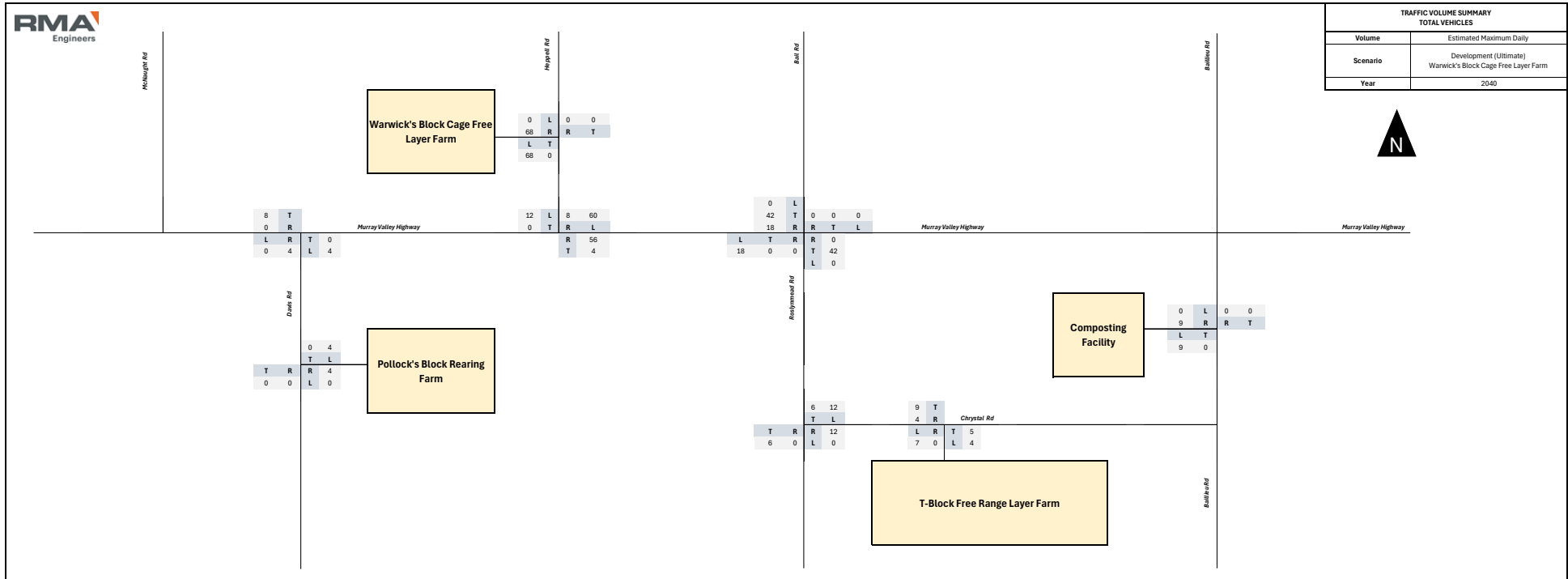

PEAK HOUR VOLUME SUMMARY LIGHT VEHICLES	
Volume	AM (PM)
Scenario	Development (Ultimate) Warwick's Block Cage Free Layer Farm (Network Peak)
Year	2040

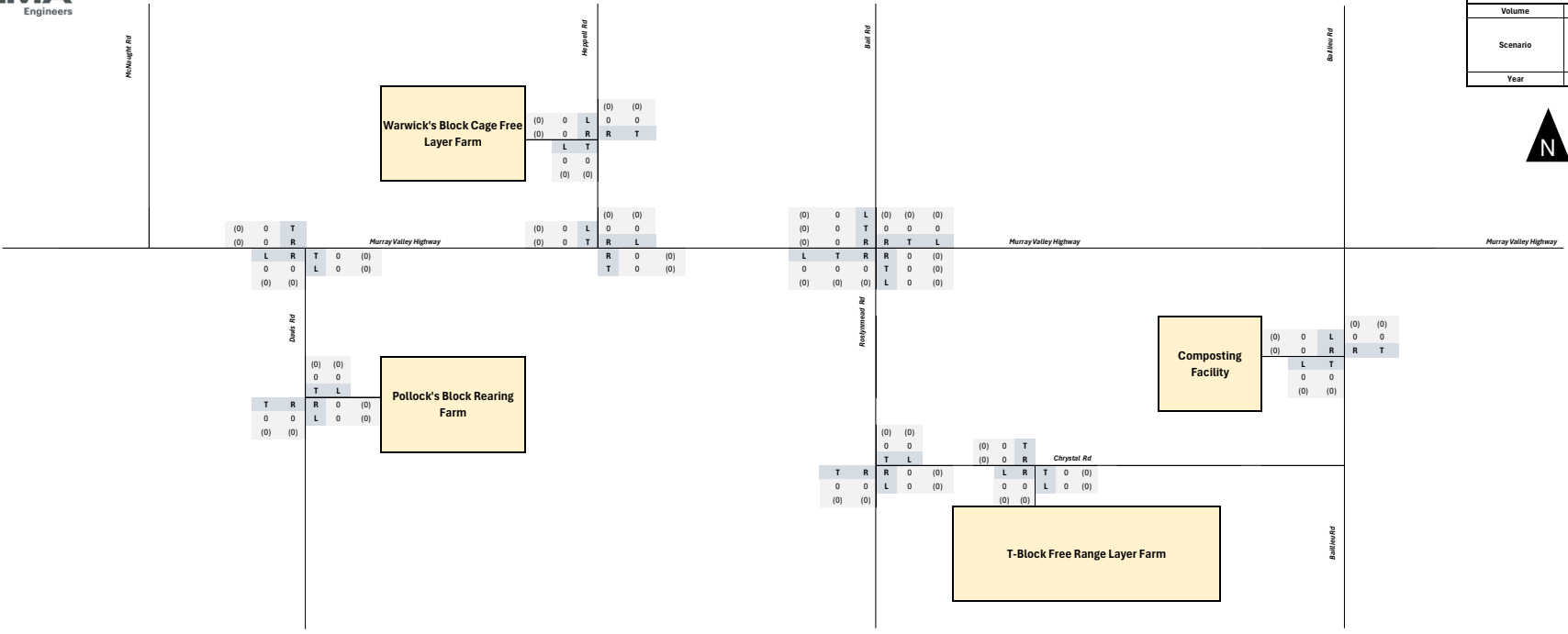

PEAK HOUR VOLUME SUMMARY	
LIGHT VEHICLES	
Volume	AM (PM)
Scenario	Development (Ultimate) Warwick's Block Cage Free Layer Farm (Development Peak 1)
Year	2040

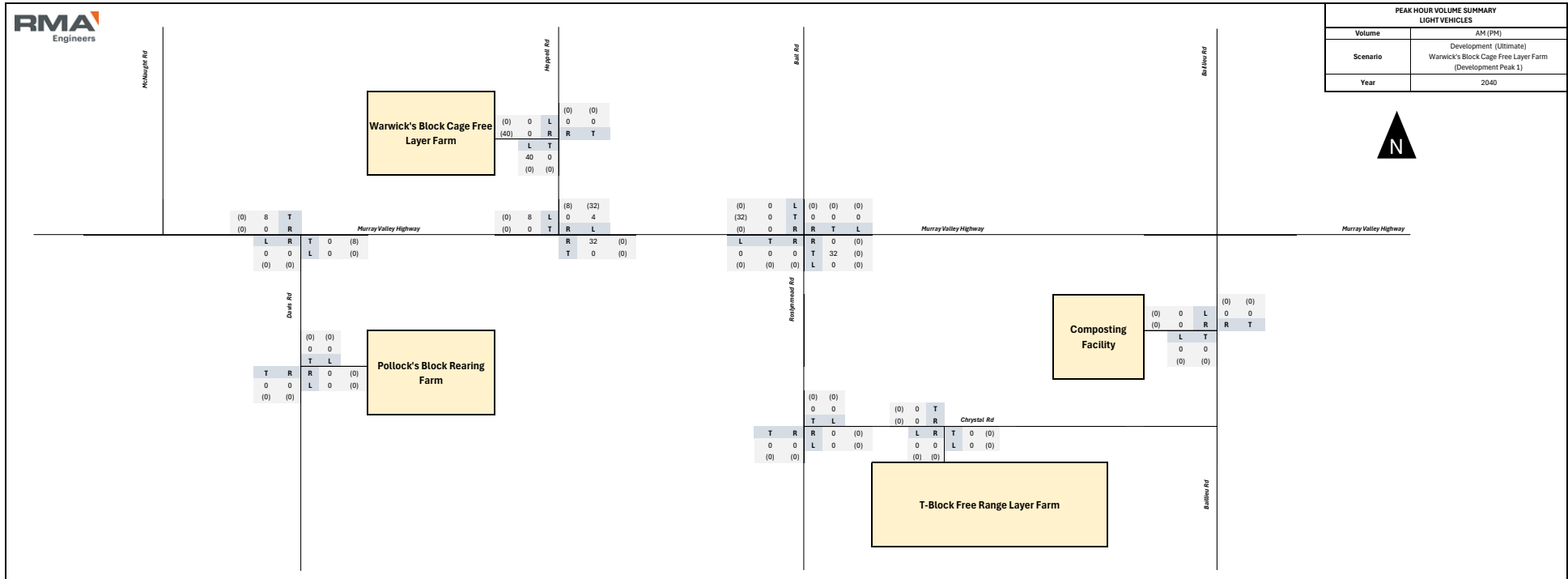

PEAK HOUR VOLUME SUMMARY LIGHT VEHICLES	
Volume	AM (PM)
Scenario	Development (Ultimate) Warwick's Block Cage Free Layer Farm (Development Peak 2)
Year	2040

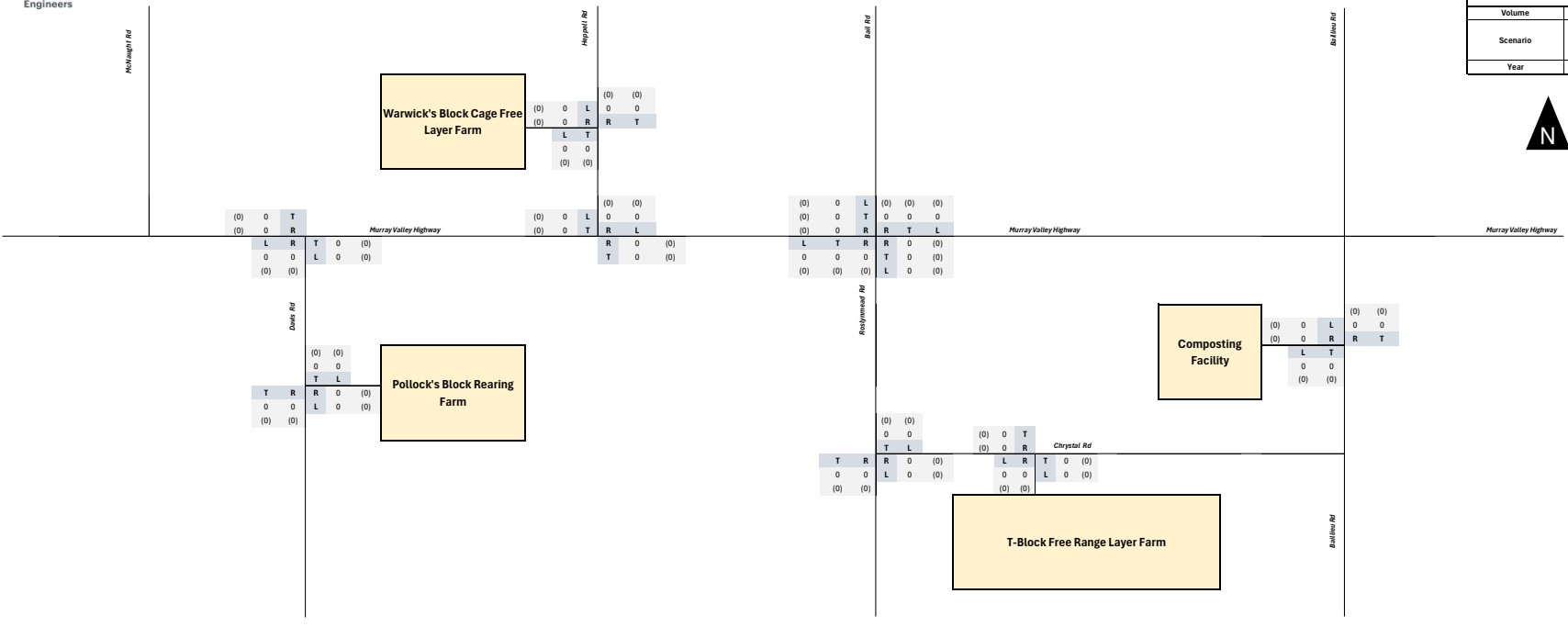

TRAFFIC VOLUME SUMMARY	
LIGHT VEHICLES	
Volume	Estimated Maximum Daily
Scenario	Development (Ultimate) Warwick's Block Cage Free Layer Farm
Year	2040

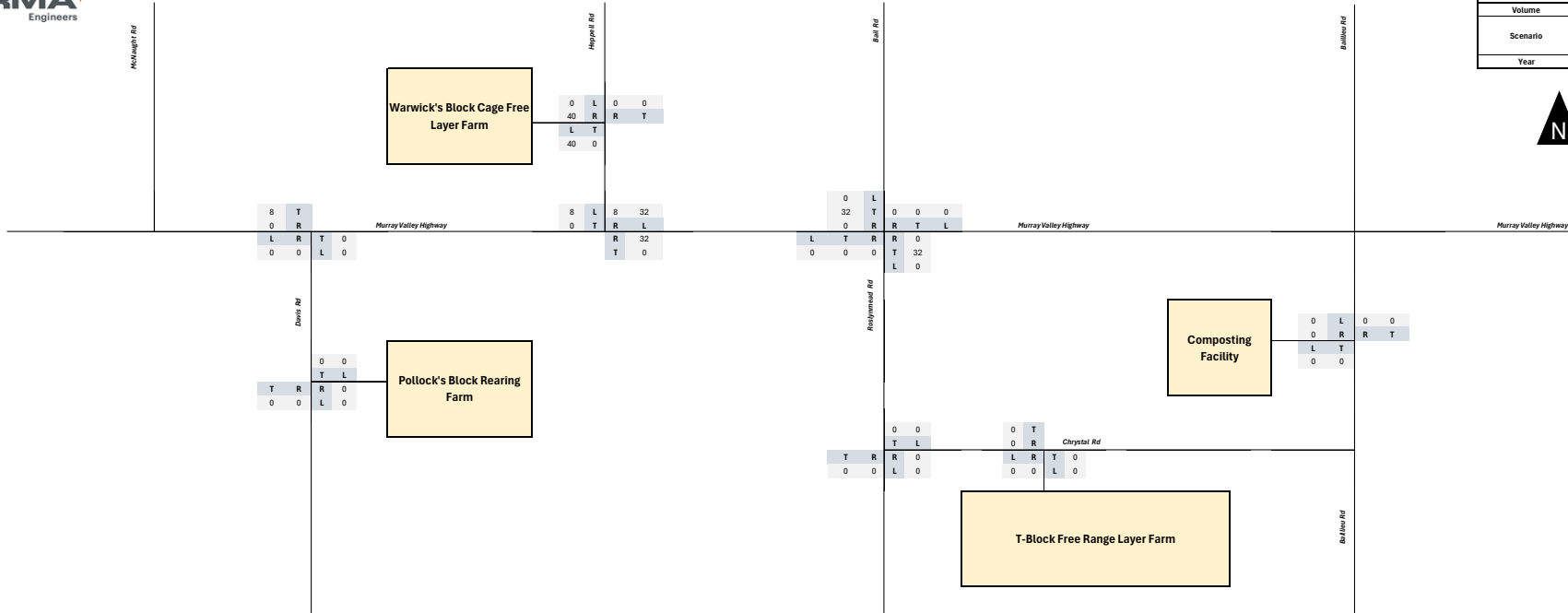

PEAK HOUR VOLUME SUMMARY HEAVY VEHICLES	
Volume	AM (PM)
Scenario	Development (Ultimate) Warwick's Block Cage Free Layer Farm (Network Peak)
Year	2040

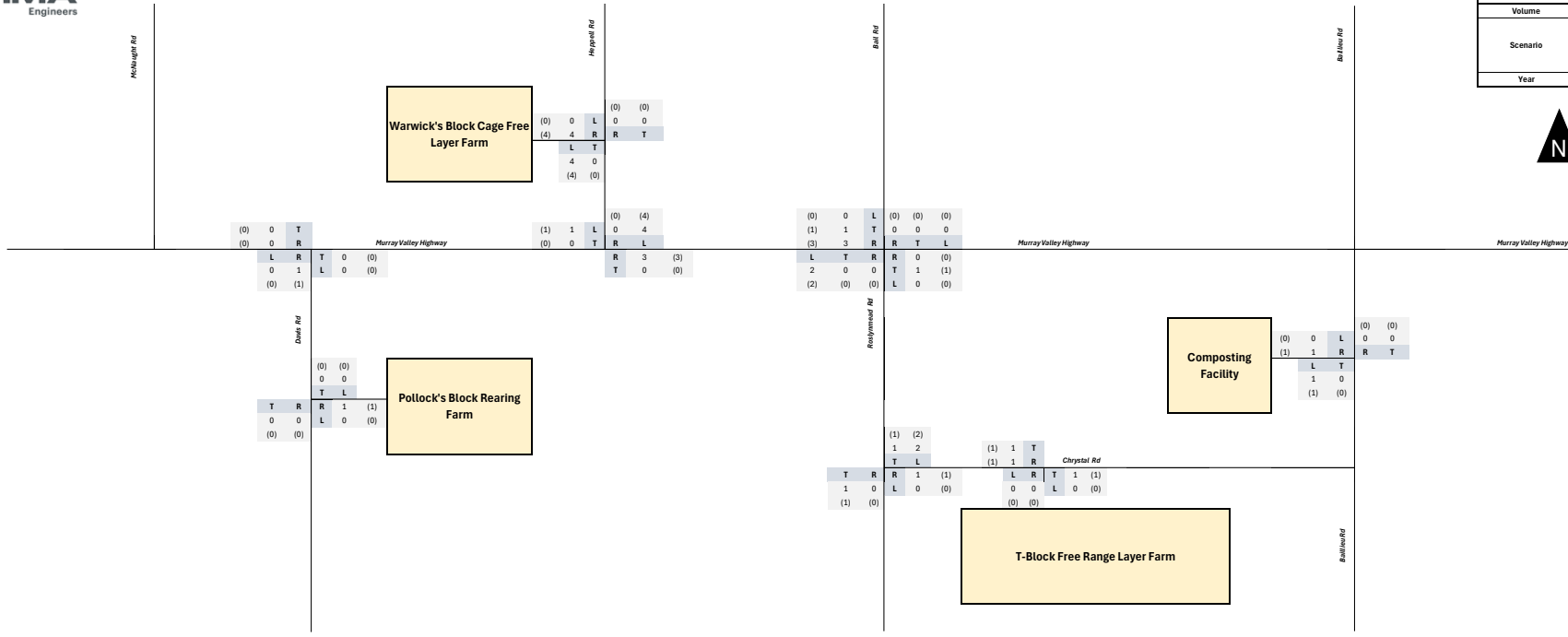

PEAK HOUR VOLUME SUMMARY	
HEAVY VEHICLES	
Volume	AM (PM)
Scenario	Development (Ultimate) Warwick's Block Cage Free Layer Farm (Development Peak 1)
Year	2040

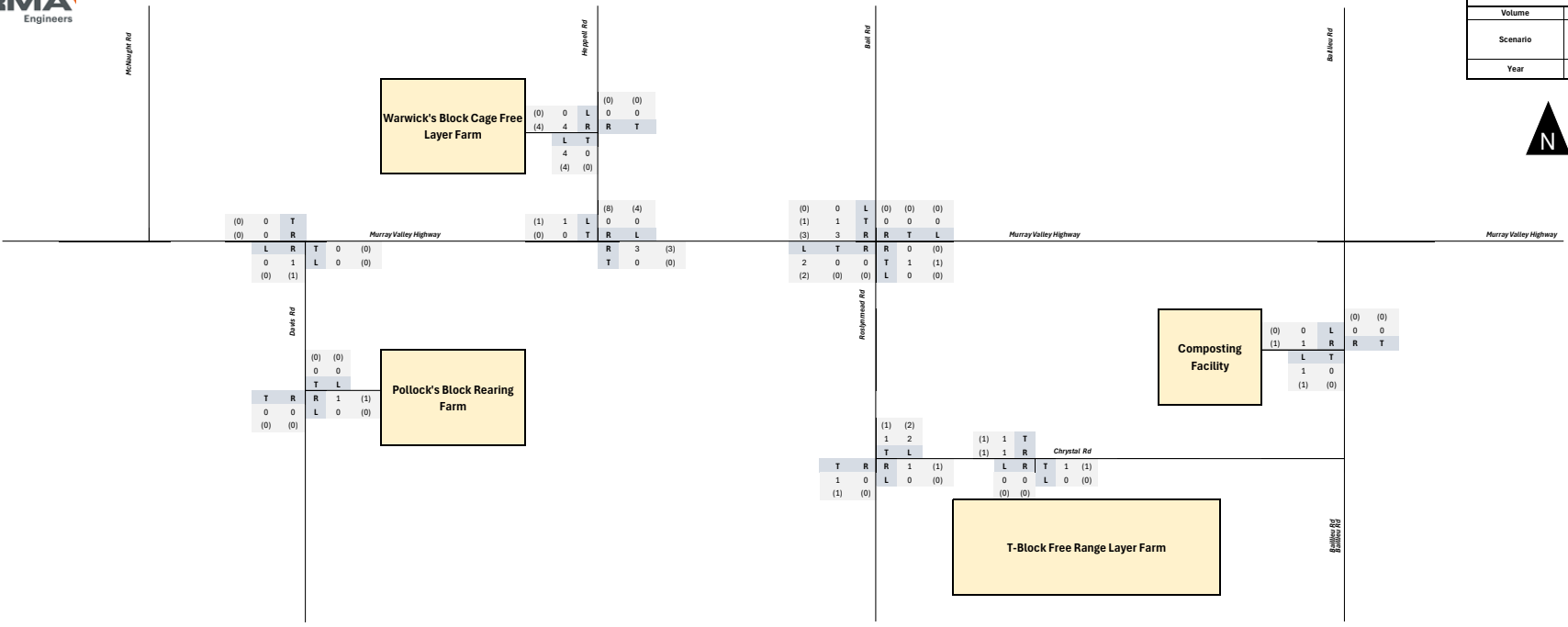

PEAK HOUR VOLUME SUMMARY HEAVY VEHICLES	
Volume	AM (PM)
Scenario	Development (Ultimate) Warwick's Block Cage Free Layer Farm (Development Peak 2)
Year	2040

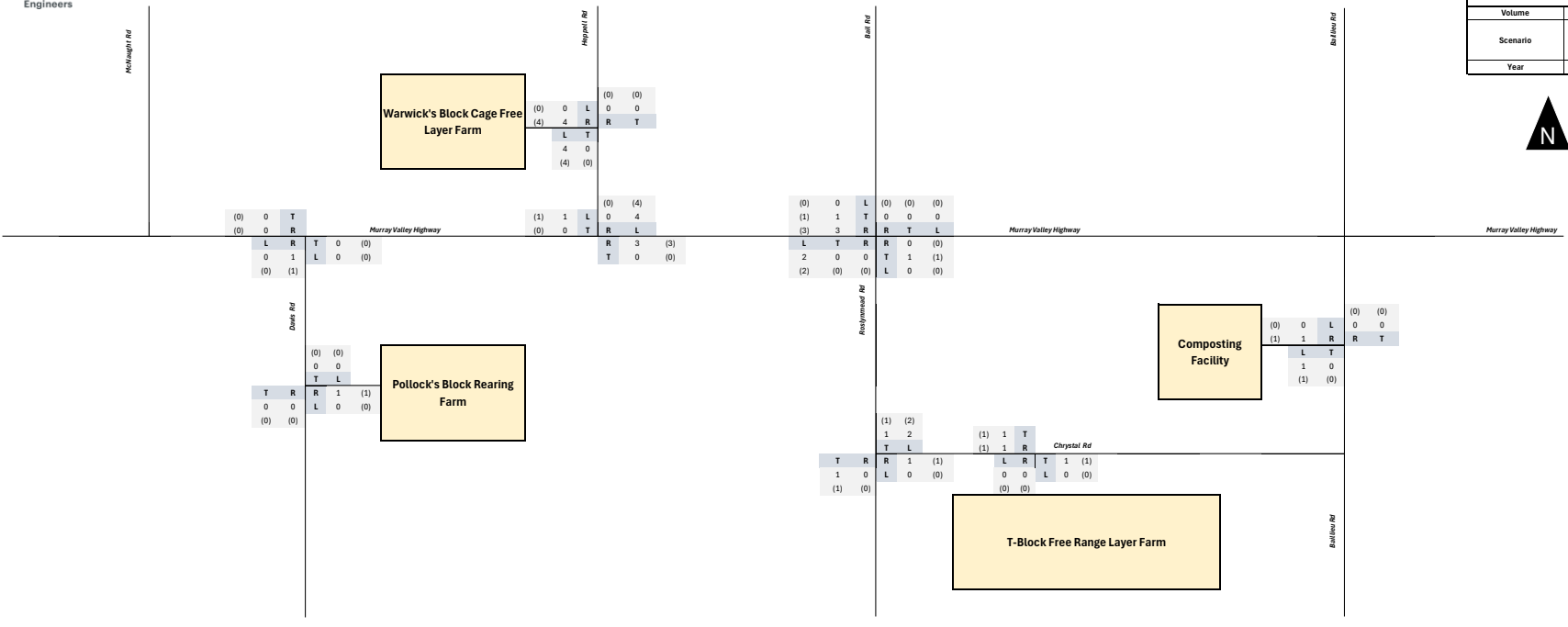

TRAFFIC VOLUME SUMMARY HEAVY VEHICLES	
Volume	Estimated Maximum Daily
Scenario	Development (Ultimate) Warwick's Block Cage Free Layer Farm
Year	2040

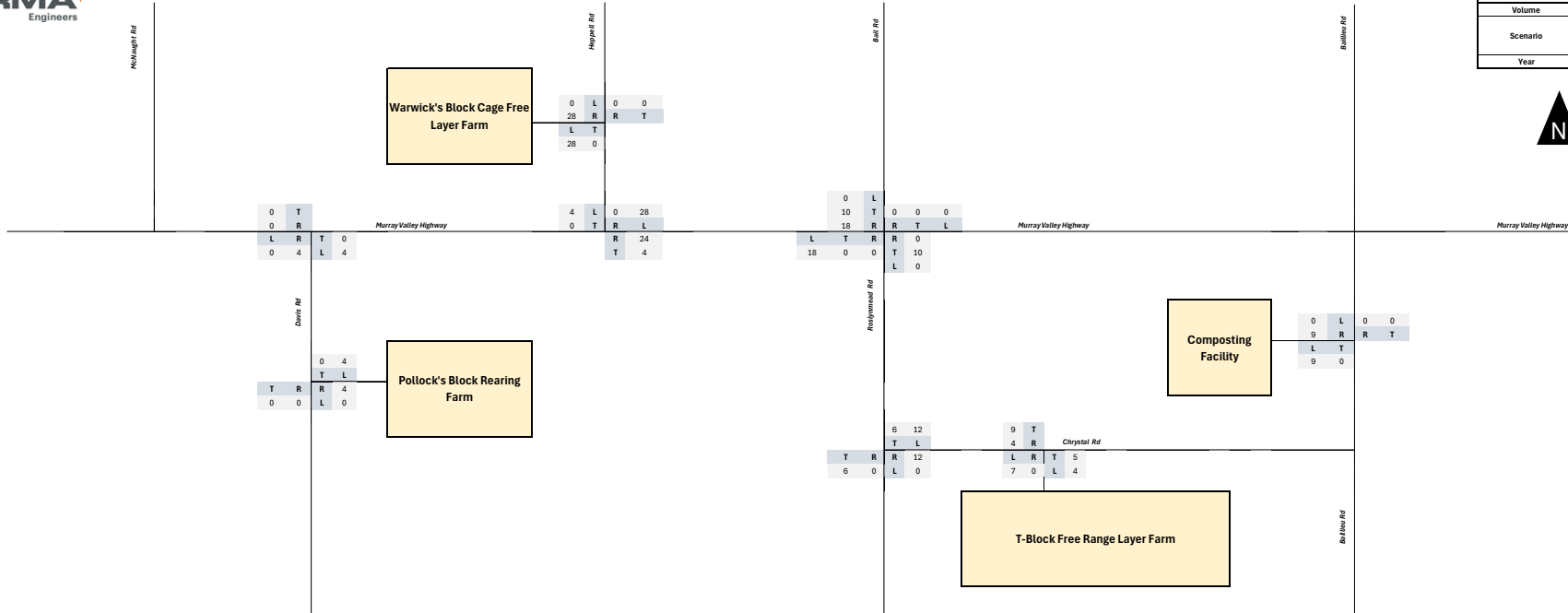

PEAK HOUR VOLUME SUMMARY	
TOTAL VEHICLES	
Volume	AM (PM)
Scenario	Development (Ultimate) T-Block Free Range Layer Farm (Network Peak)
Year	2042

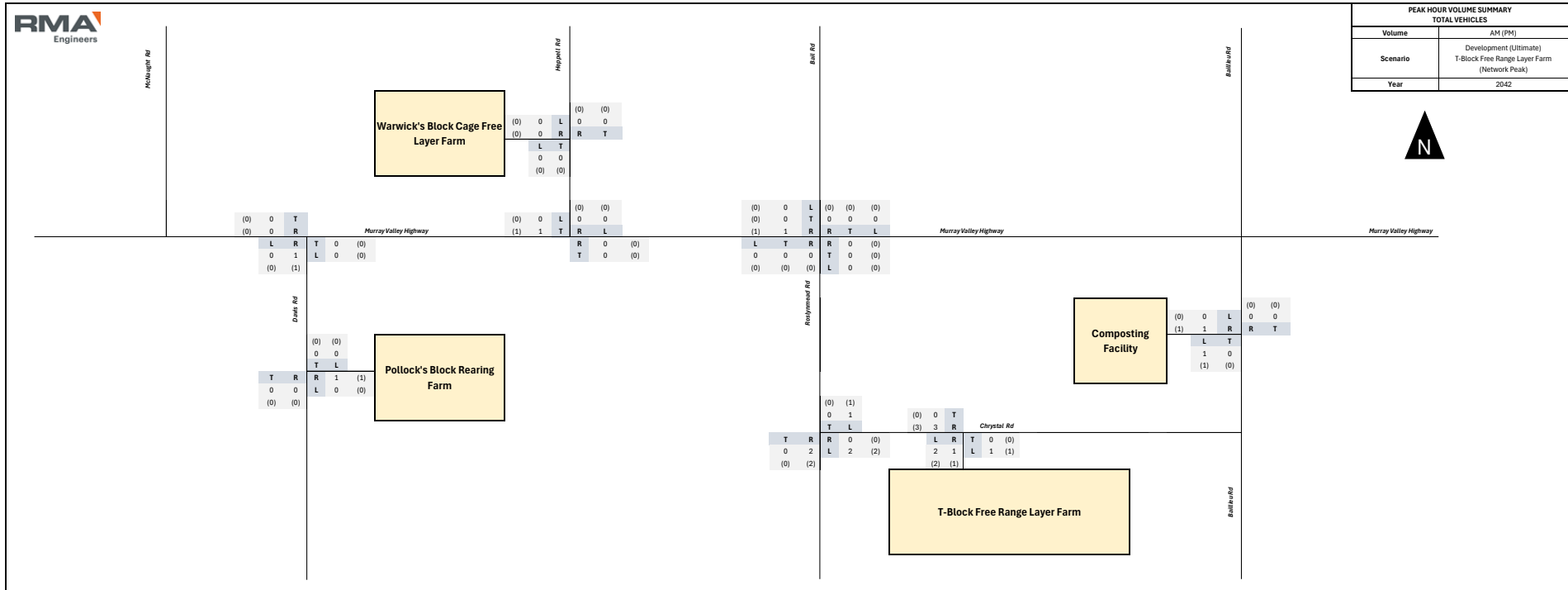

PEAK HOUR VOLUME SUMMARY	
TOTAL VEHICLES	
Volume	AM (PM)
Scenario	Development (Ultimate) T-Block Free Range Layer Farm (Development Peak 1)
Year	2042

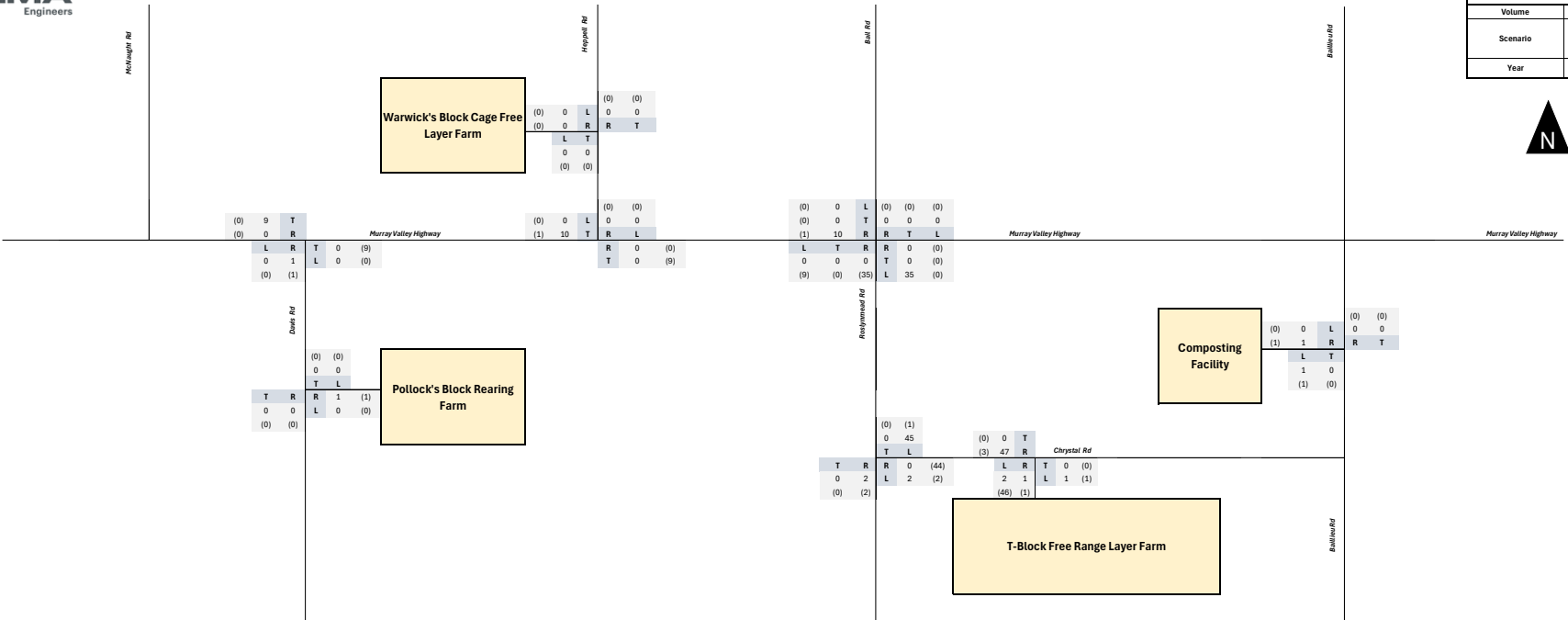

PEAK HOUR VOLUME SUMMARY	
TOTAL VEHICLES	
Volume	AM (PM)
Scenario	Development (Ultimate) T-Block Free Range Layer Farm (Development Peak 2)
Year	2042

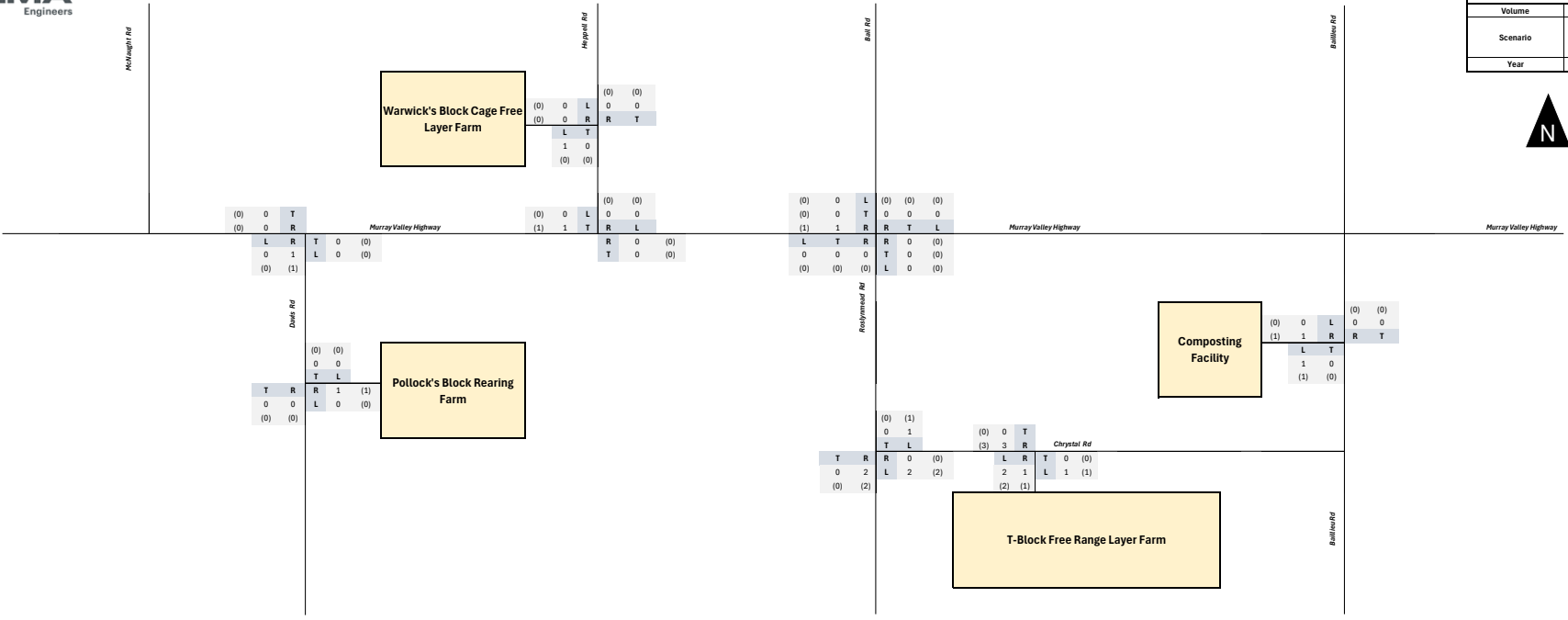

TRAFFIC VOLUME SUMMARY	
TOTAL VEHICLES	
Volume	Estimated Maximum Daily
Scenario	Development (Ultimate) T-Block Free Range Layer Farm
Year	2042

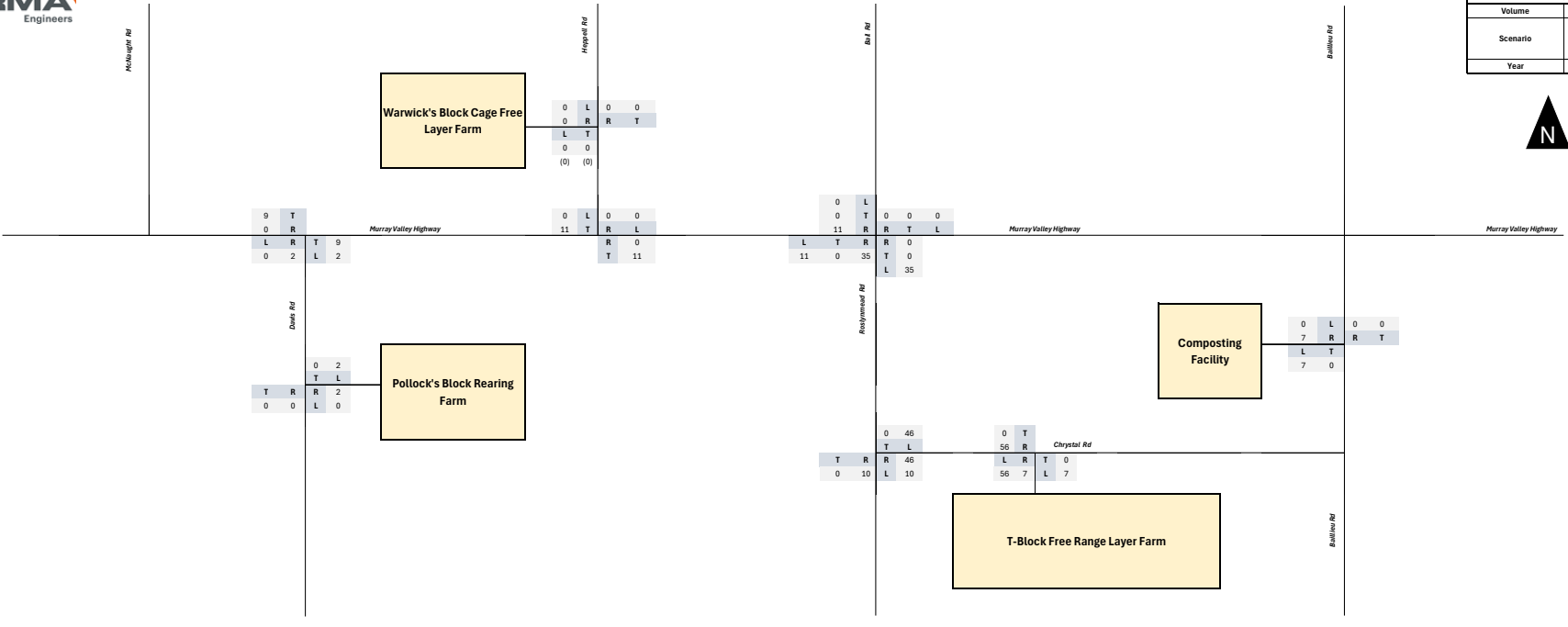

PEAK HOUR VOLUME SUMMARY	
LIGHT VEHICLES	
Volume	AM (PM)
Scenario	Development (Ultimate) T-Block Free Range Layer Farm (Network Peak)
Year	2042

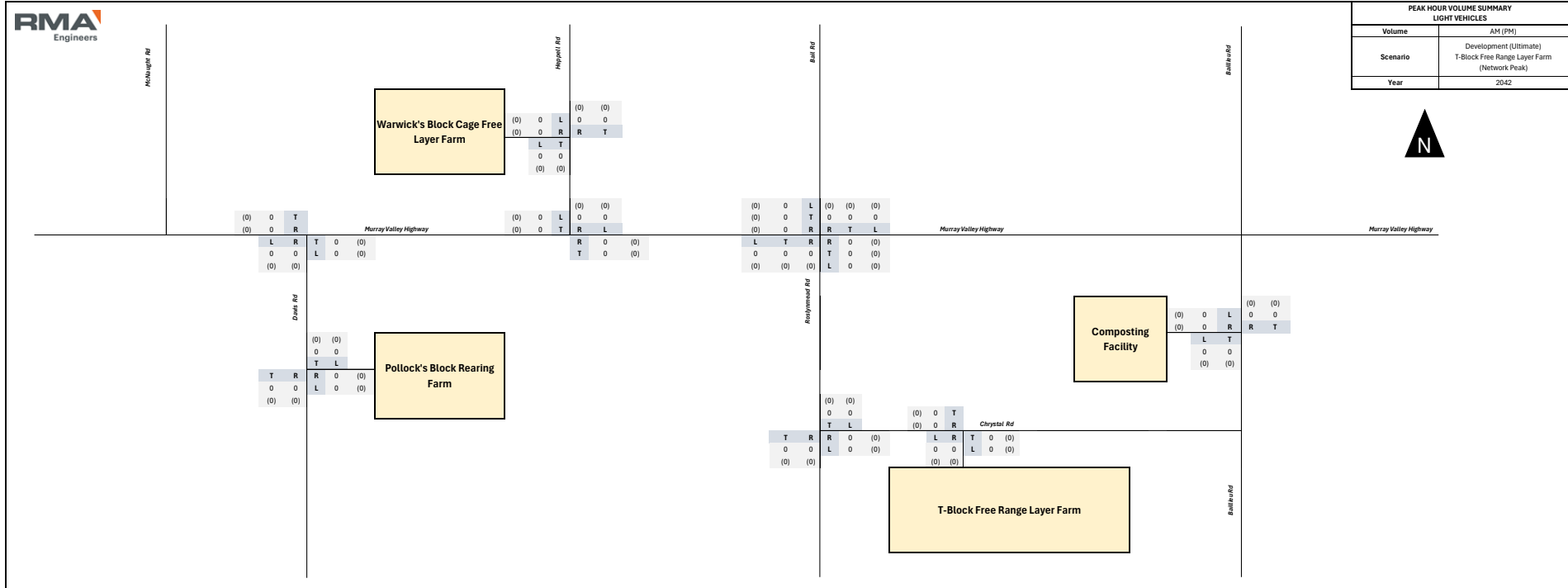

PEAK HOUR VOLUME SUMMARY LIGHT VEHICLES	
Volume	AM (PM)
Scenario	Development (Ultimate) T-Block Free Range Layer Farm (Development Peak 1)
Year	2042

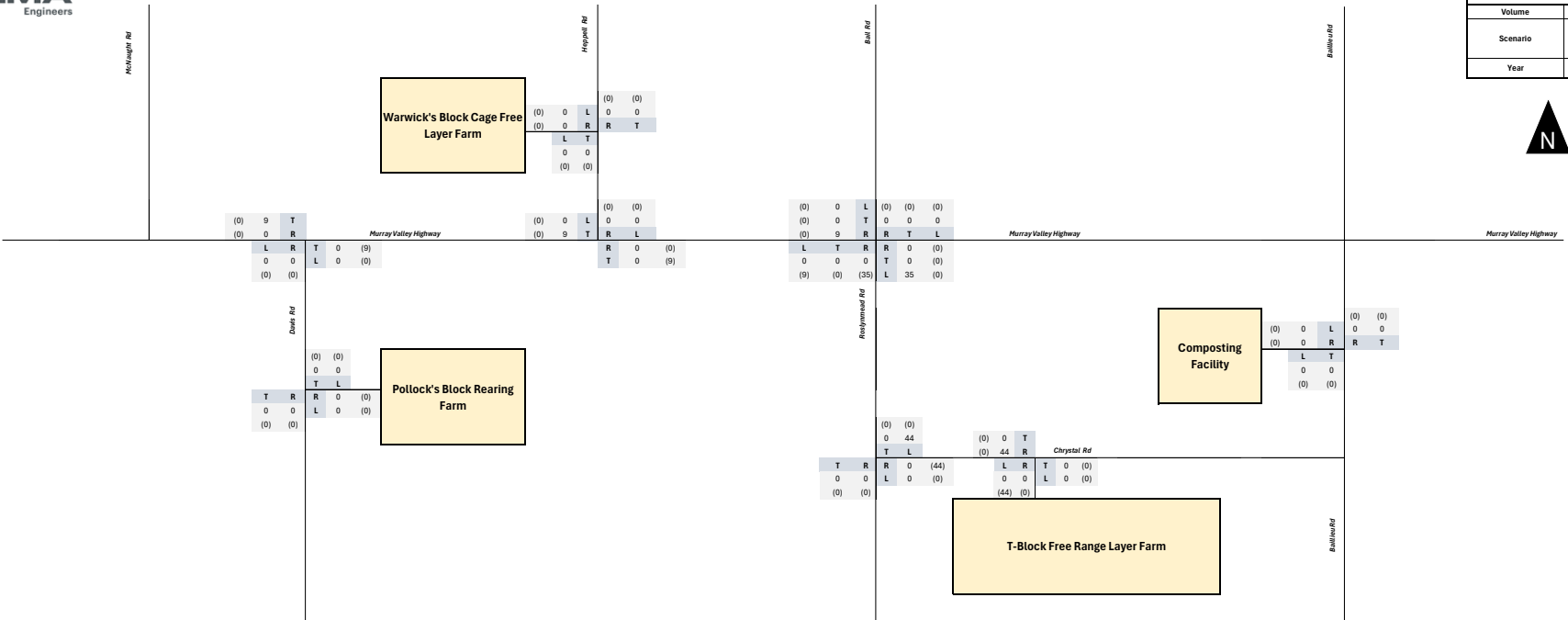

PEAK HOUR VOLUME SUMMARY LIGHT VEHICLES	
Volume	AM (PM)
Scenario	Development (Ultimate) T-Block Free Range Layer Farm (Development Peak 2)
Year	2042

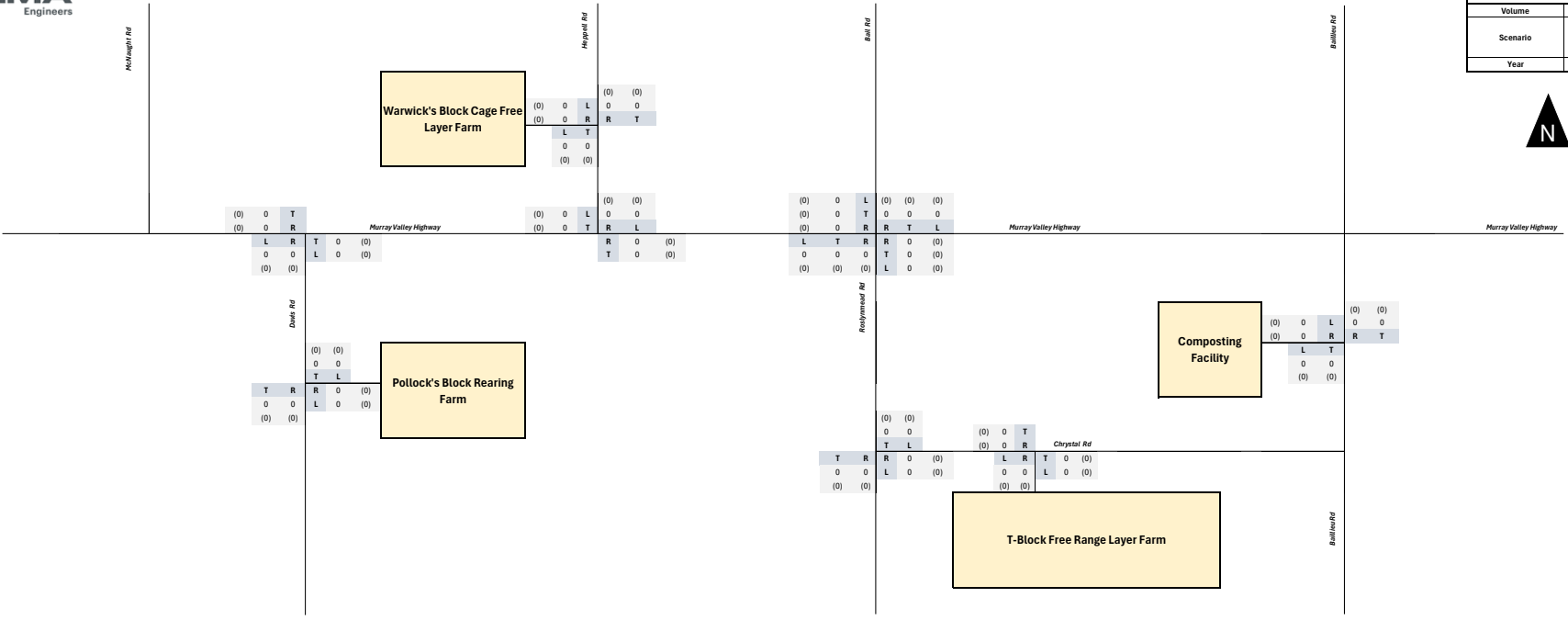

TRAFFIC VOLUME SUMMARY	
LIGHT VEHICLES	
Volume	Estimated Maximum Daily
Scenario	Development (Ultimate) T-Block Free Range Layer Farm
Year	2042

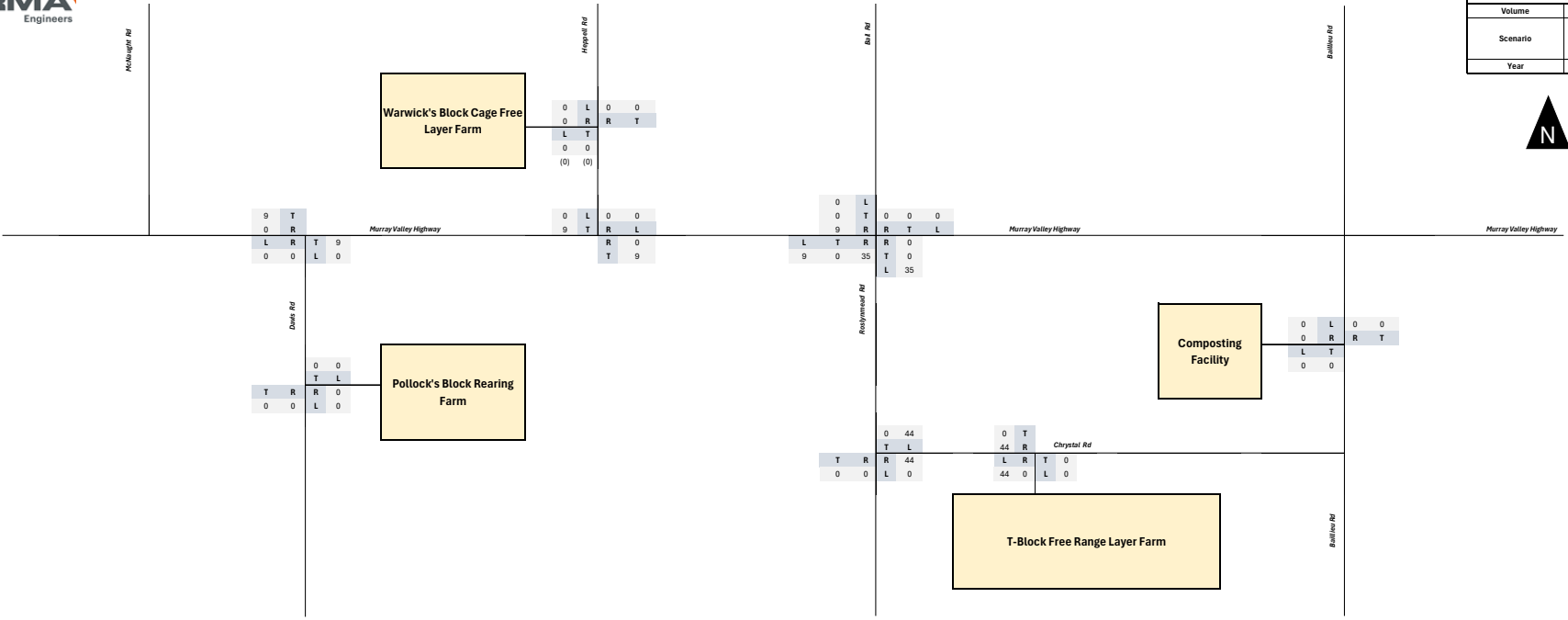

PEAK HOUR VOLUME SUMMARY HEAVY VEHICLES	
Volume	AM (PM)
Scenario	Development (Ultimate) T-Block Free Range Layer Farm (Network Peak)
Year	2042

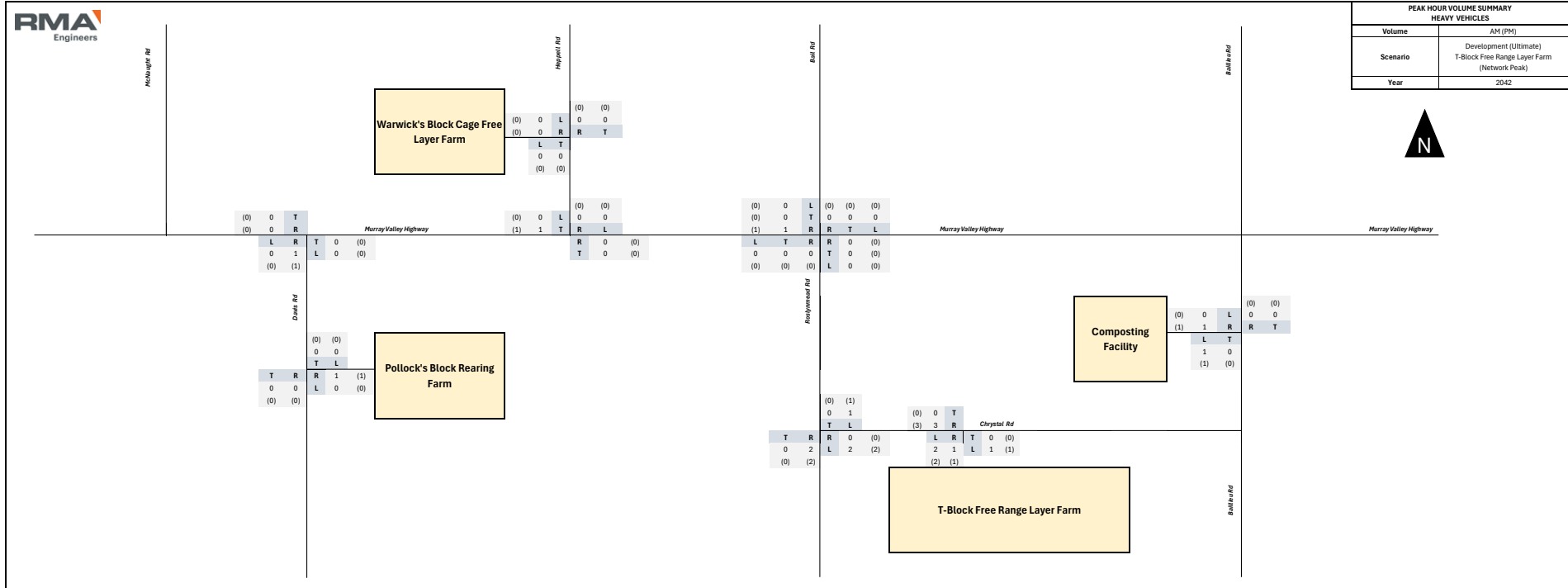

PEAK HOUR VOLUME SUMMARY HEAVY VEHICLES	
Volume	AM (PM)
Scenario	Development (Ultimate) T-Block Free Range Layer Farm (Development Peak 1)
Year	2042

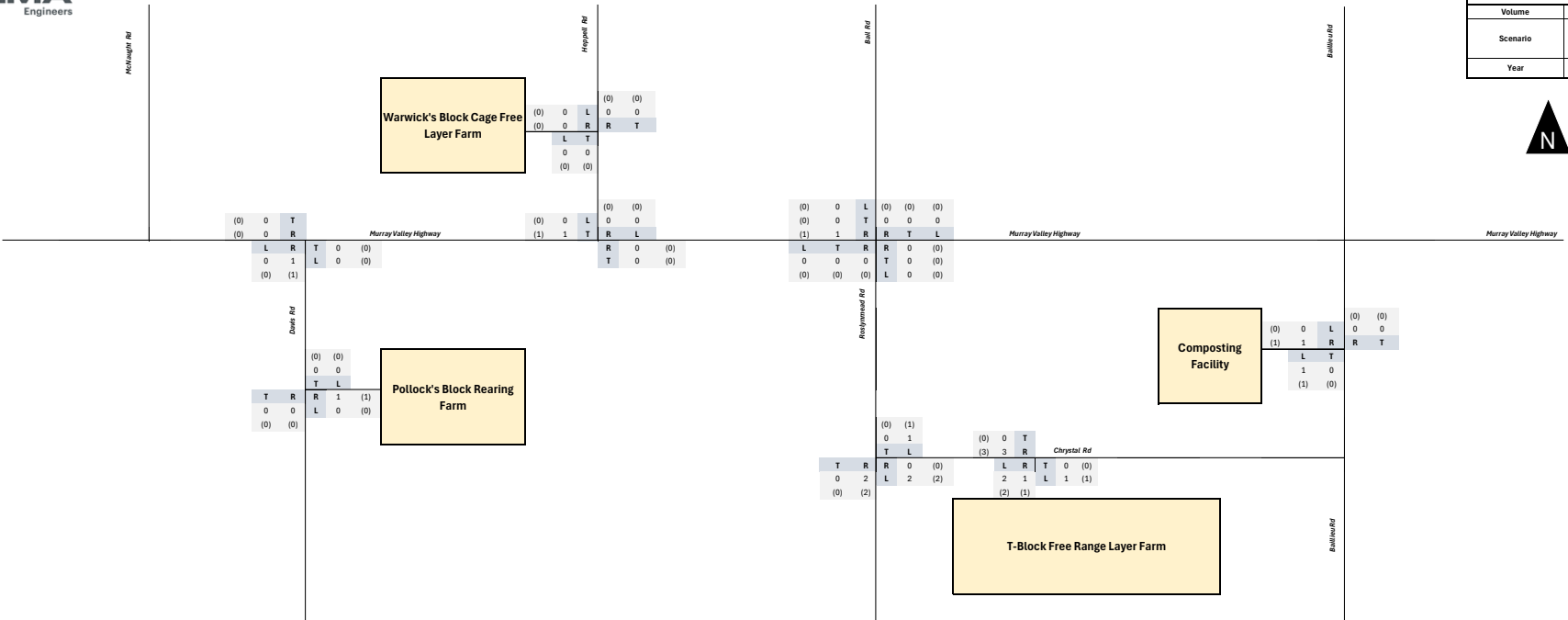

PEAK HOUR VOLUME SUMMARY HEAVY VEHICLES	
Volume	AM (PM)
Scenario	Development (Ultimate) T-Block Free Range Layer Farm (Development Peak 2)
Year	2042

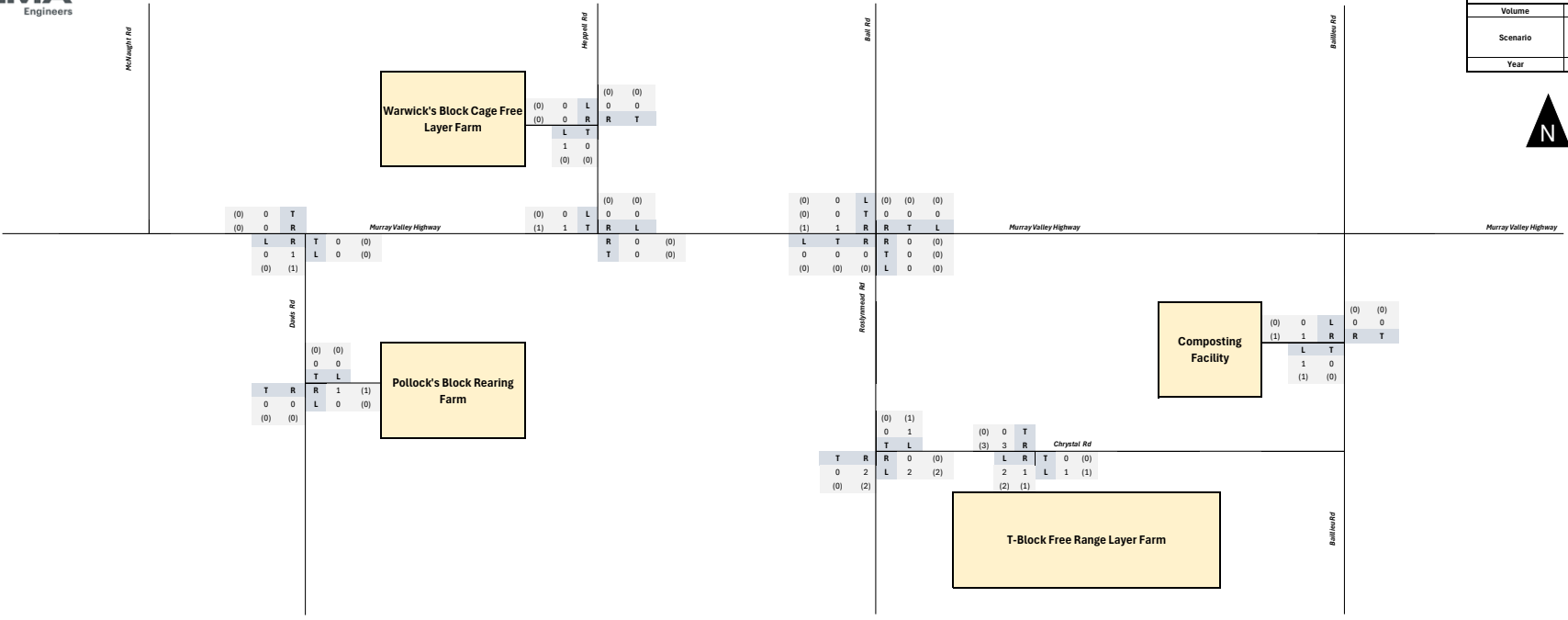

TRAFFIC VOLUME SUMMARY HEAVY VEHICLES	
Volume	Estimated Maximum Daily
Scenario	Development (Ultimate) T-Block Free Range Layer Farm
Year	2042

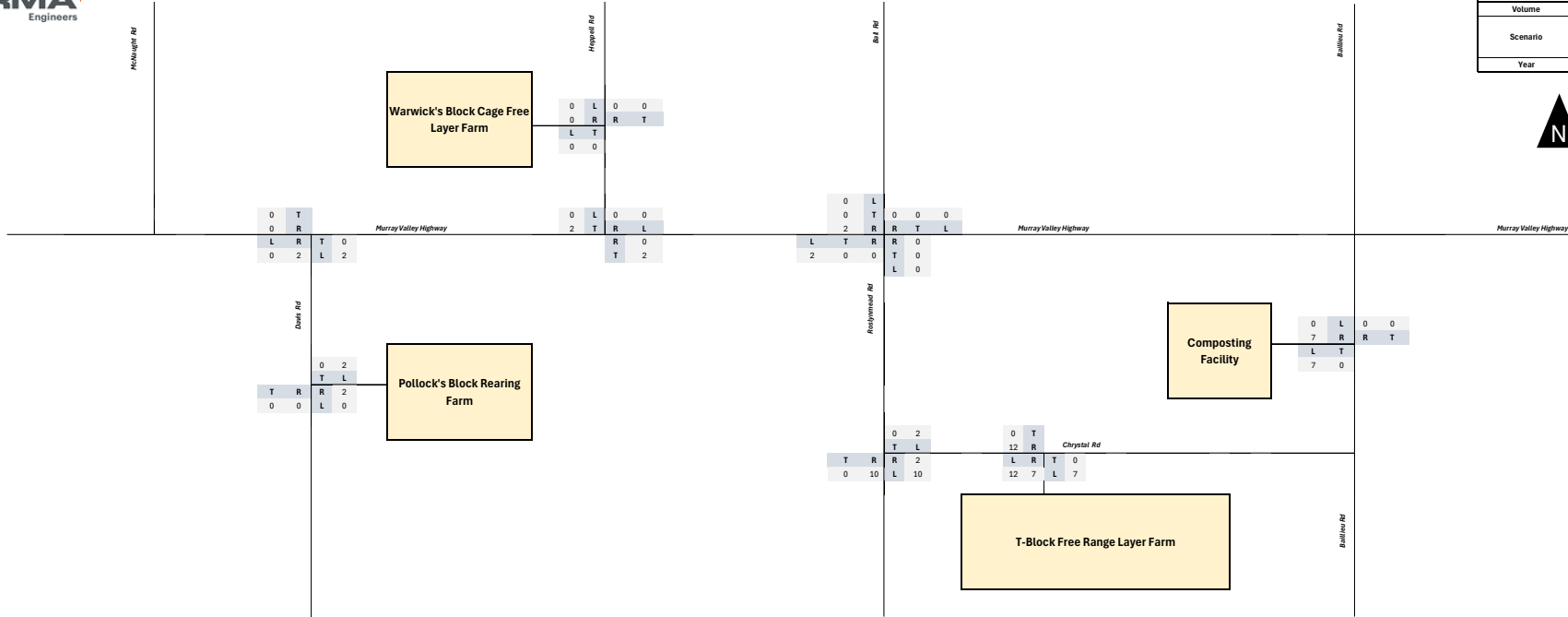

PEAK HOUR VOLUME SUMMARY	
TOTAL VEHICLES	
Volume	AM (PM)
Scenario	Development (Ultimate) Composting Facility (Network Peak)
Year	2042

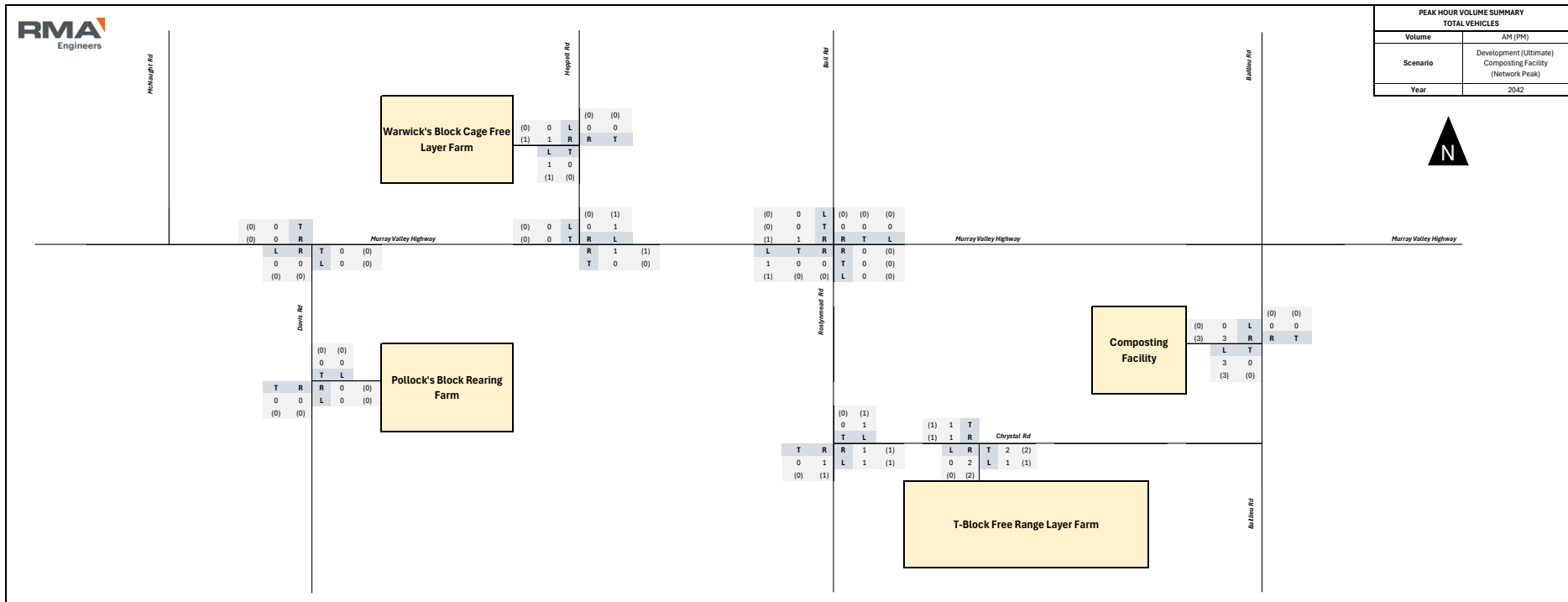

PEAK HOUR VOLUME SUMMARY TOTAL VEHICLES	
Volume	AM (PM)
Scenario	Development (Ultimate) Composting Facility (Development Peak 1)
Year	2042

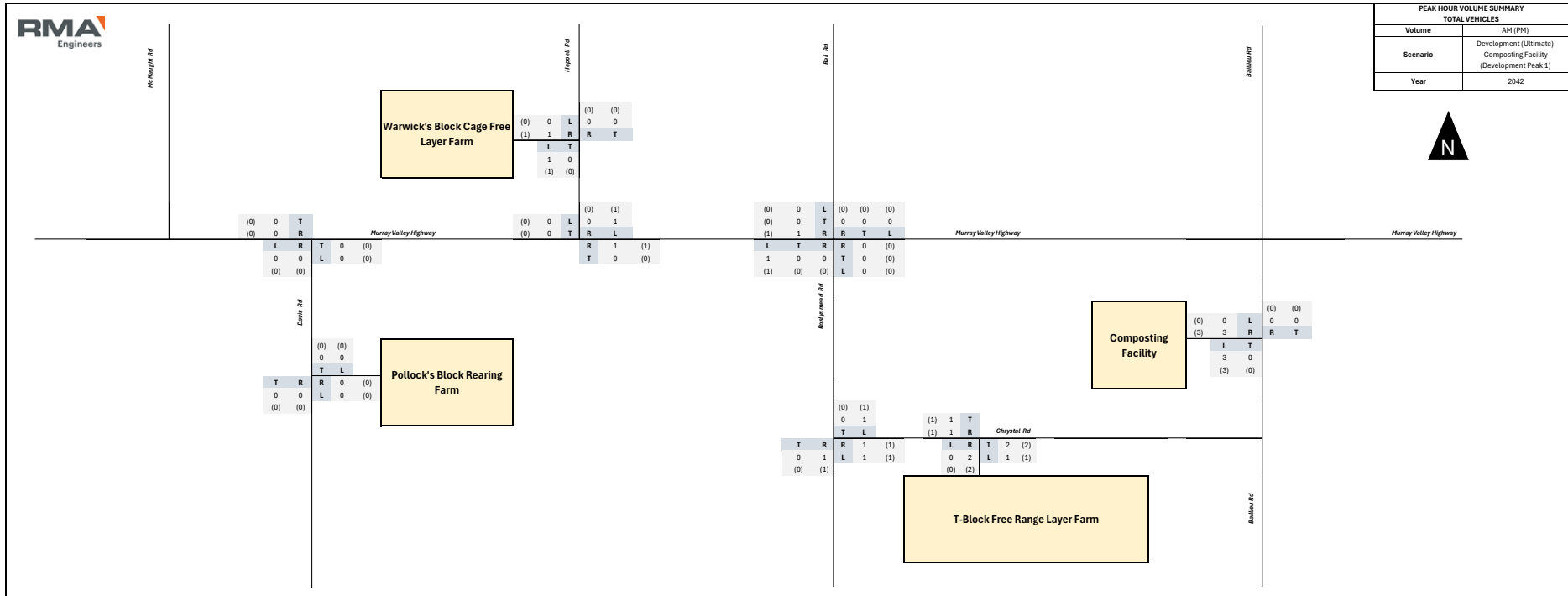

Houghton Rd

Hargrave Rd

Balfour Rd

Balfour Rd

Warwick's Block Cage Free Layer Farm

Pollock's Block Rearing Farm

Composting Facility

T-Block Free Range Layer Farm

Murray Valley Highway

Murray Valley Highway

Murray Valley Highway

Danks Rd

Ruyter Rd

Crystal Rd

Balfour Rd

(0)	0	T
(0)	0	R
L	R	T
0	0	0
0	0	0
(0)	(0)	

(0)	0	L	(0)	(0)
(1)	1	R	0	0
		L	T	
		1	0	
(1)	(0)			

(0)	0	L	(0)	(1)
(0)	0	R	0	1
		L	T	
		1	0	(1)
(0)	(0)			

(0)	0	L	(0)	(0)	(0)
(0)	0	R	0	0	0
(1)	1	R	R	T	L
		L	T	R	
		1	0	0	
(1)	(0)	(0)	L	0	(0)

(0)	(0)
0	0
T	L
0	0
0	0
(0)	(0)

(0)	0	L	(0)	(0)
(3)	3	R	0	0
		L	T	
		3	0	
(3)	(0)			

(0)	(1)
0	1
T	L
0	1
(0)	(1)

(1)	1	T
(1)	1	R
L	R	T
0	2	L
(0)	(2)	

PEAK HOUR VOLUME SUMMARY TOTAL VEHICLES	
Volume	AM (PM)
Scenario	Development (Ultimate) Composting Facility (Development Peak 2)
Year	2042

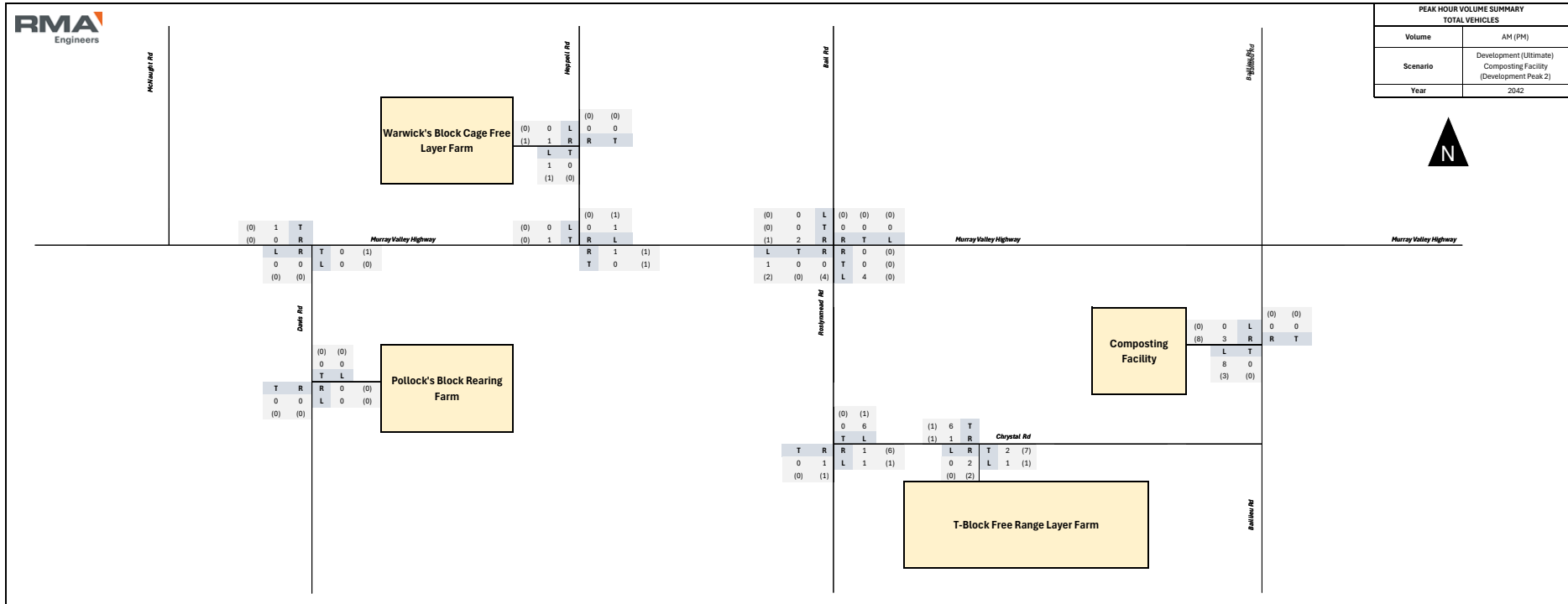

TRAFFIC VOLUME SUMMARY	
TOTAL VEHICLES	
Volume	Estimated Maximum Daily
Scenario	Development (Ultimate) Composting Facility
Year	2042

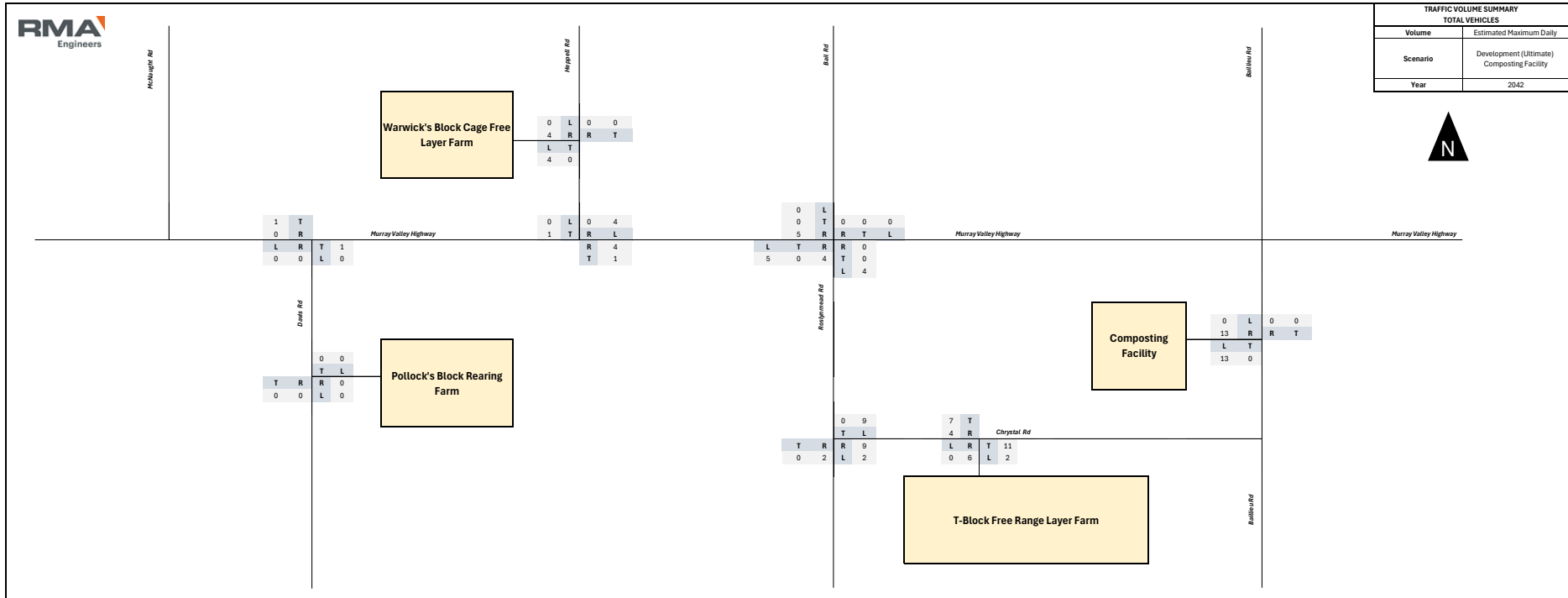

PEAK HOUR VOLUME SUMMARY	
LIGHT VEHICLES	
Volume	AM (PM)
Scenario	Development (Ultimate) Composting Facility (Network Peak)
Year	2042

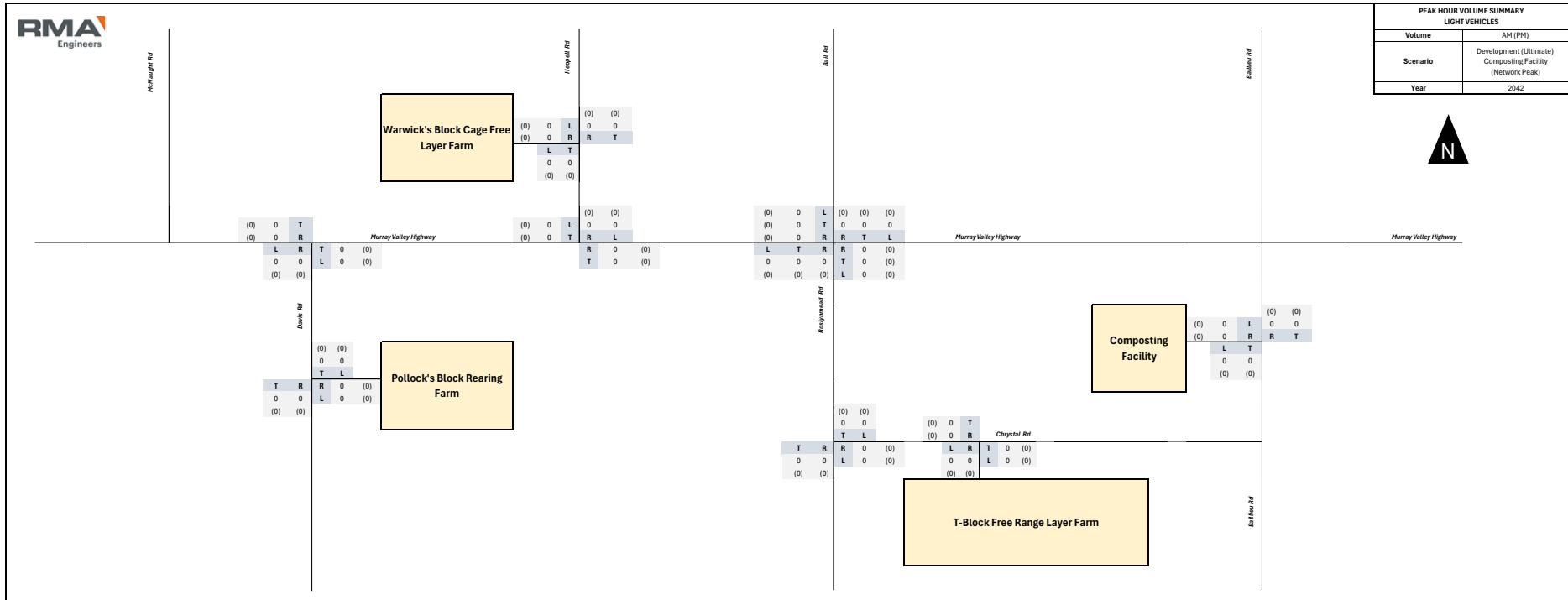

PEAK HOUR VOLUME SUMMARY	
LIGHT VEHICLES	
Volume	AM (PM)
Scenario	Development (Ultimate) Composting Facility (Development Peak 1)
Year	2042

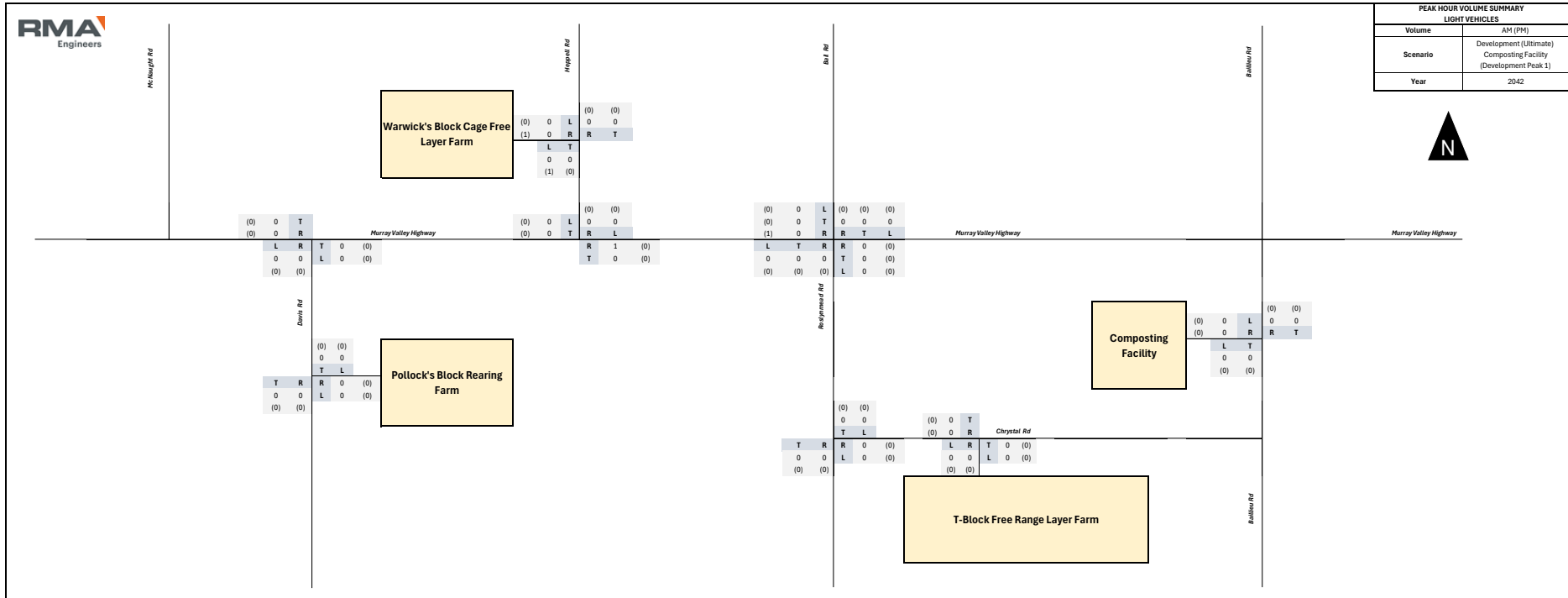

PEAK HOUR VOLUME SUMMARY LIGHT VEHICLES	
Volume	AM (PM)
Scenario	Development (Ultimate) Composting Facility (Development Peak 2)
Year	2042

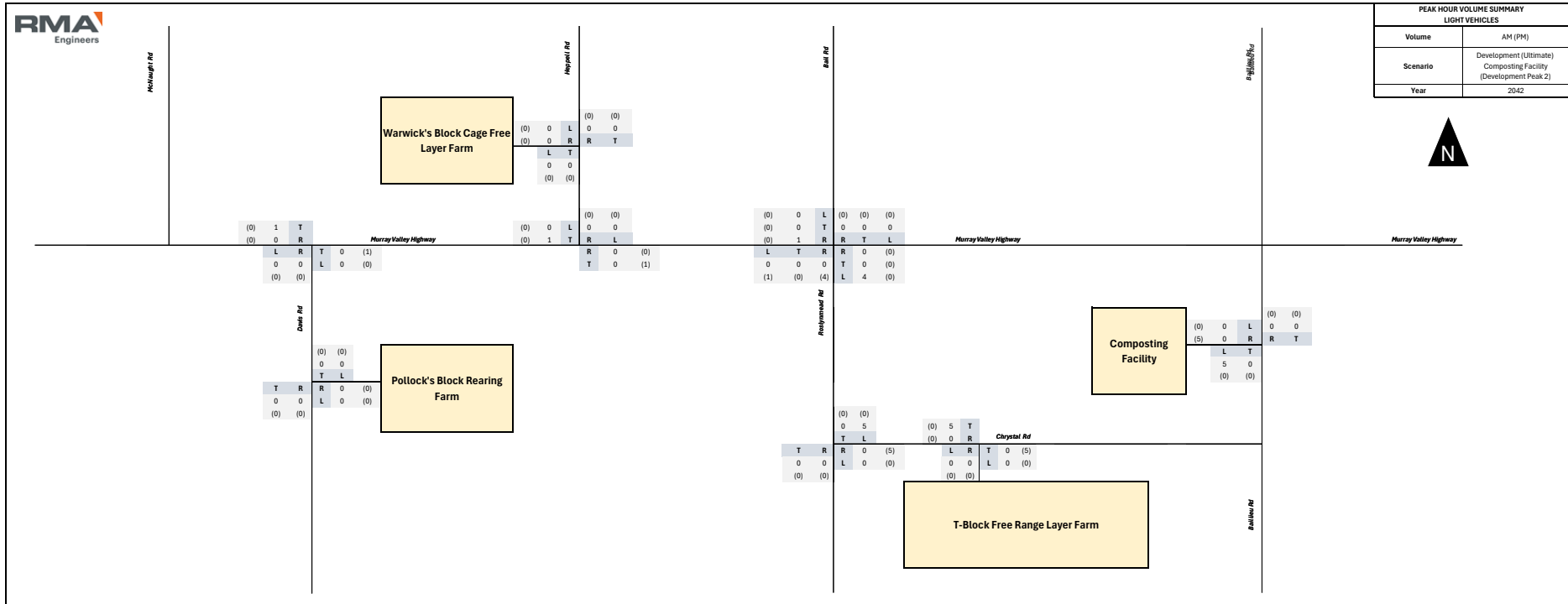

TRAFFIC VOLUME SUMMARY LIGHT VEHICLES	
Volume	Estimated Maximum Daily
Scenario	Development (Ultimate) Composting Facility
Year	2042

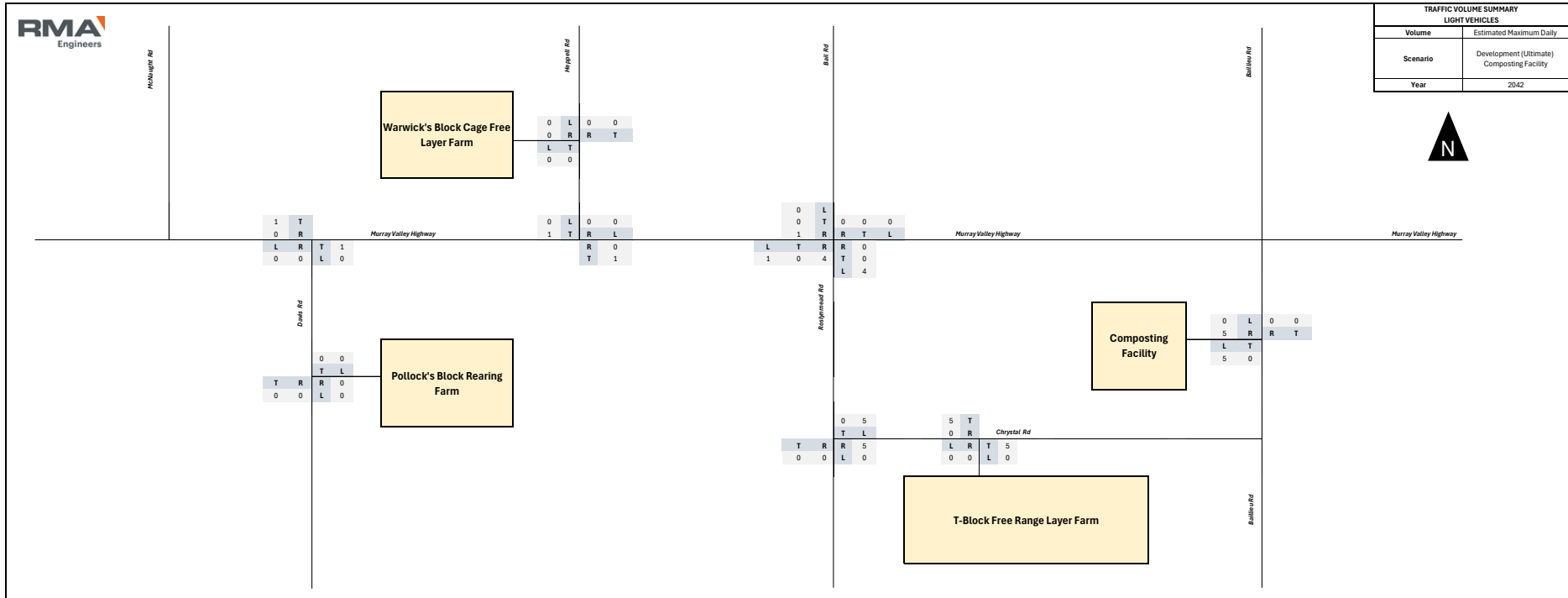

PEAK HOUR VOLUME SUMMARY	
HEAVY VEHICLES	
Volume	AM (PM)
Scenario	Development (Ultimate) Composting Facility (Network Peak)
Year	2042

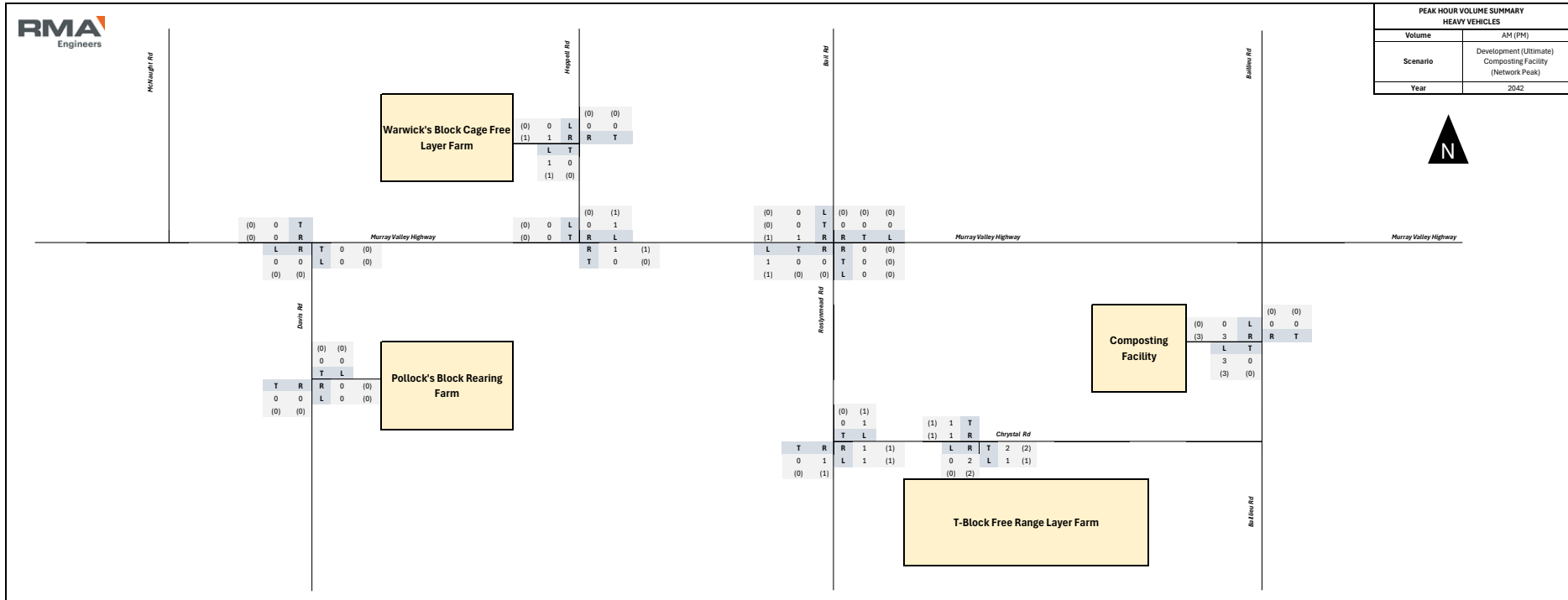

PEAK HOUR VOLUME SUMMARY HEAVY VEHICLES	
Volume	AM (PM)
Scenario	Development (Ultimate) Composting Facility (Development Peak 1)
Year	2042

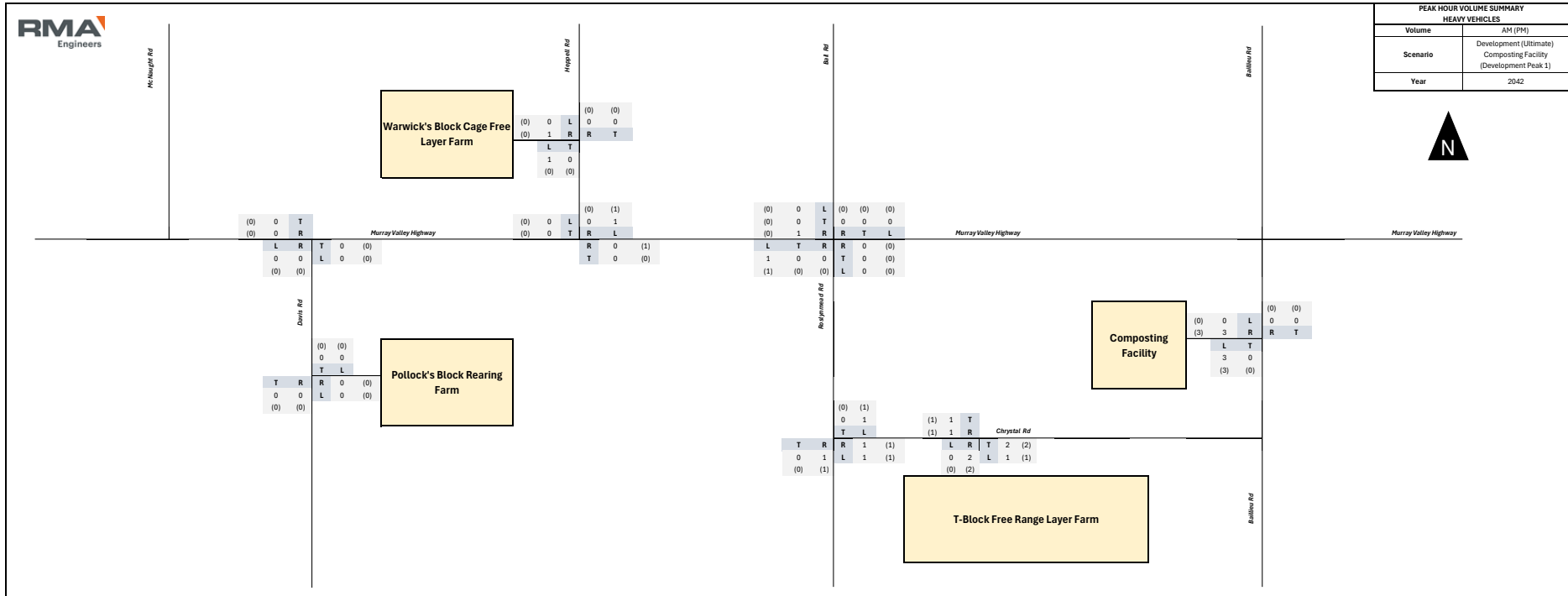

PEAK HOUR VOLUME SUMMARY HEAVY VEHICLES	
Volume	AM (PM)
Scenario	Development (Ultimate) Composting Facility (Development Peak 2)
Year	2042

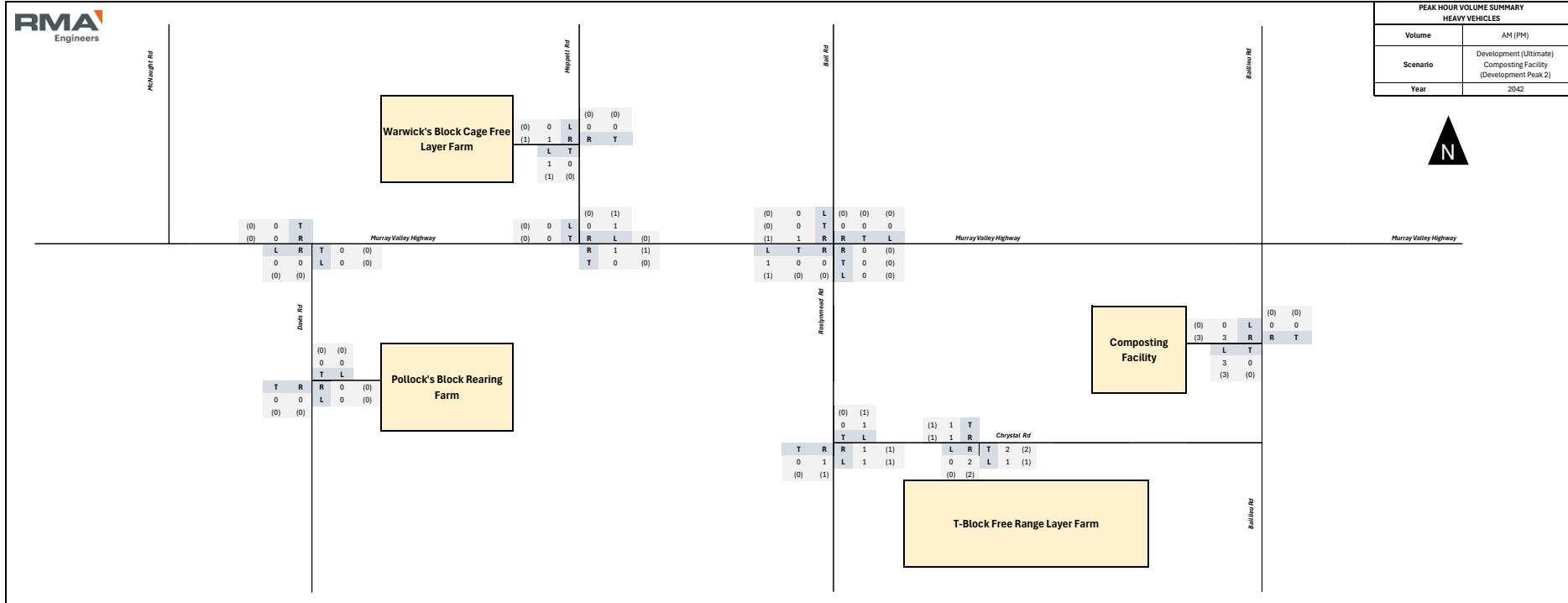

TRAFFIC VOLUME SUMMARY HEAVY VEHICLES	
Volume	Estimated Maximum Daily
Scenario	Development (Ultimate) Composting Facility
Year	2042

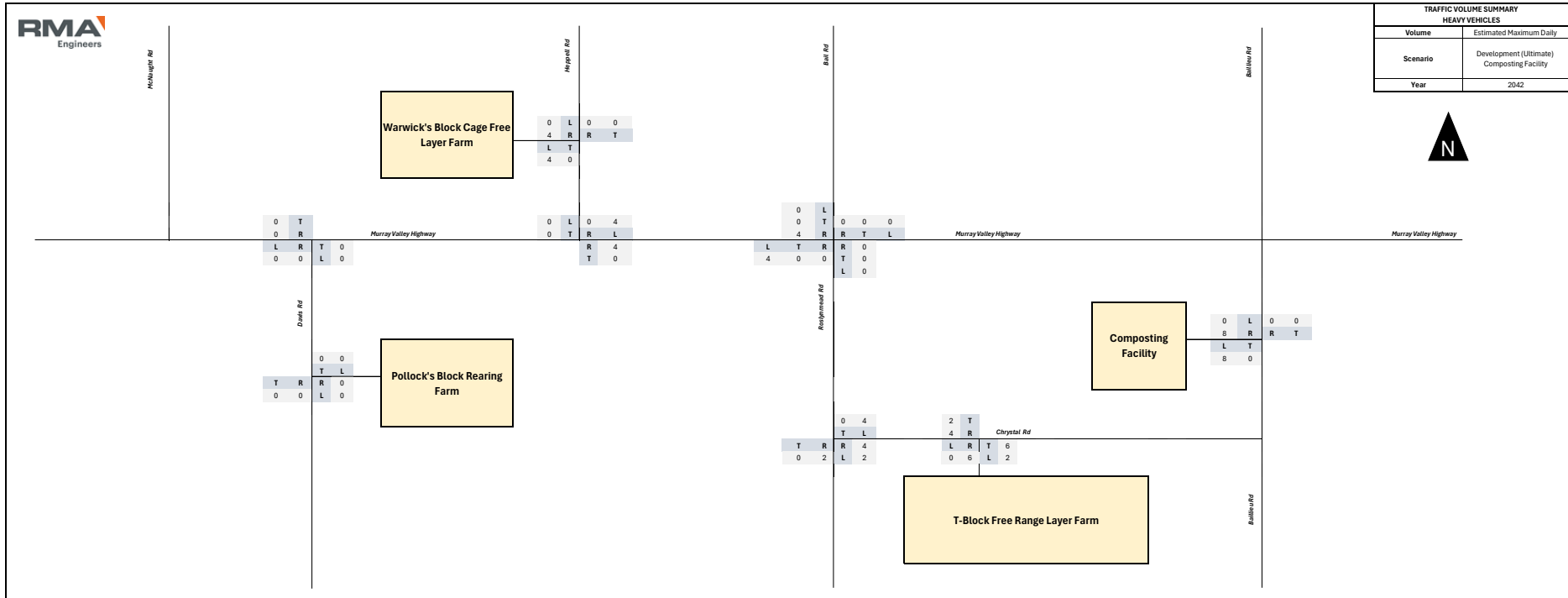

PEAK HOUR VOLUME SUMMARY TOTAL VEHICLES	
Volume	AM (PM)
Scenario	Development (Ultimate) All Sites (Network Peak)
Year	2042

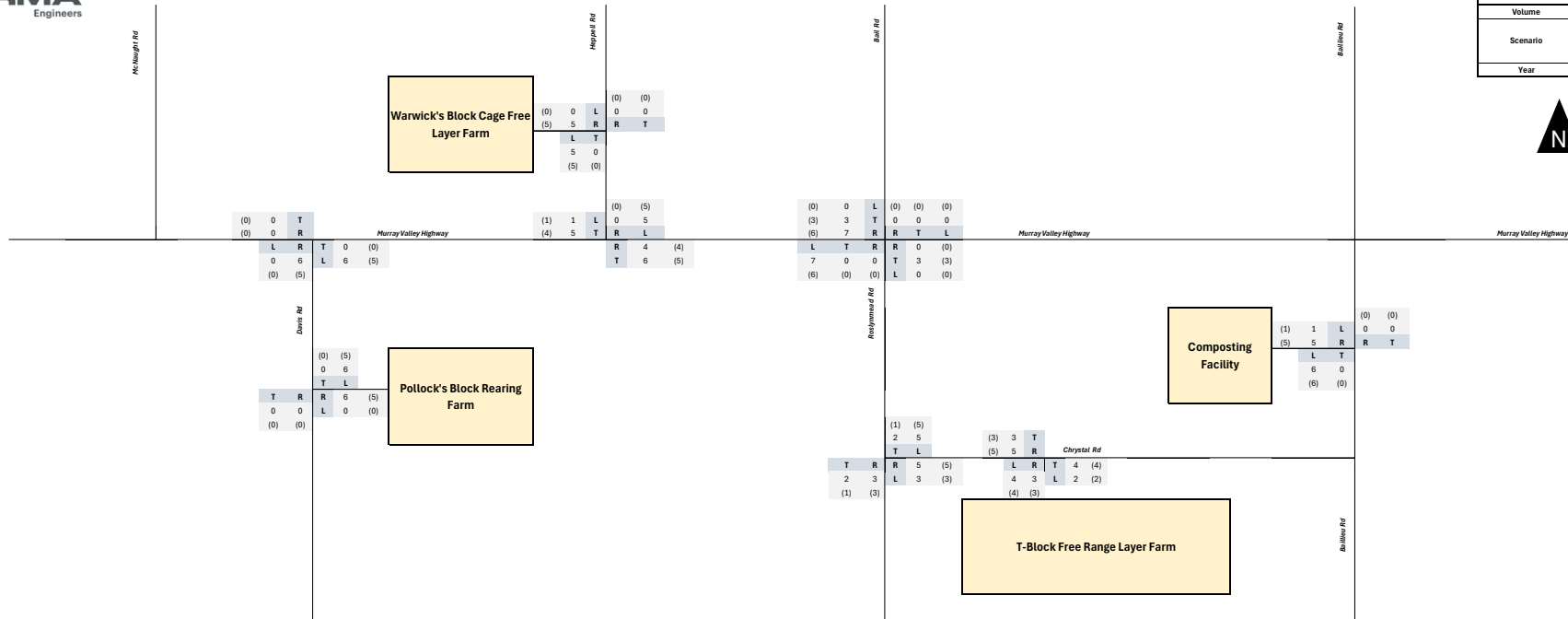

PEAK HOUR VOLUME SUMMARY TOTAL VEHICLES	
Volume	AM (PM)
Scenario	Development (Ultimate) All Sites (Development Peak 1)
Year	2042

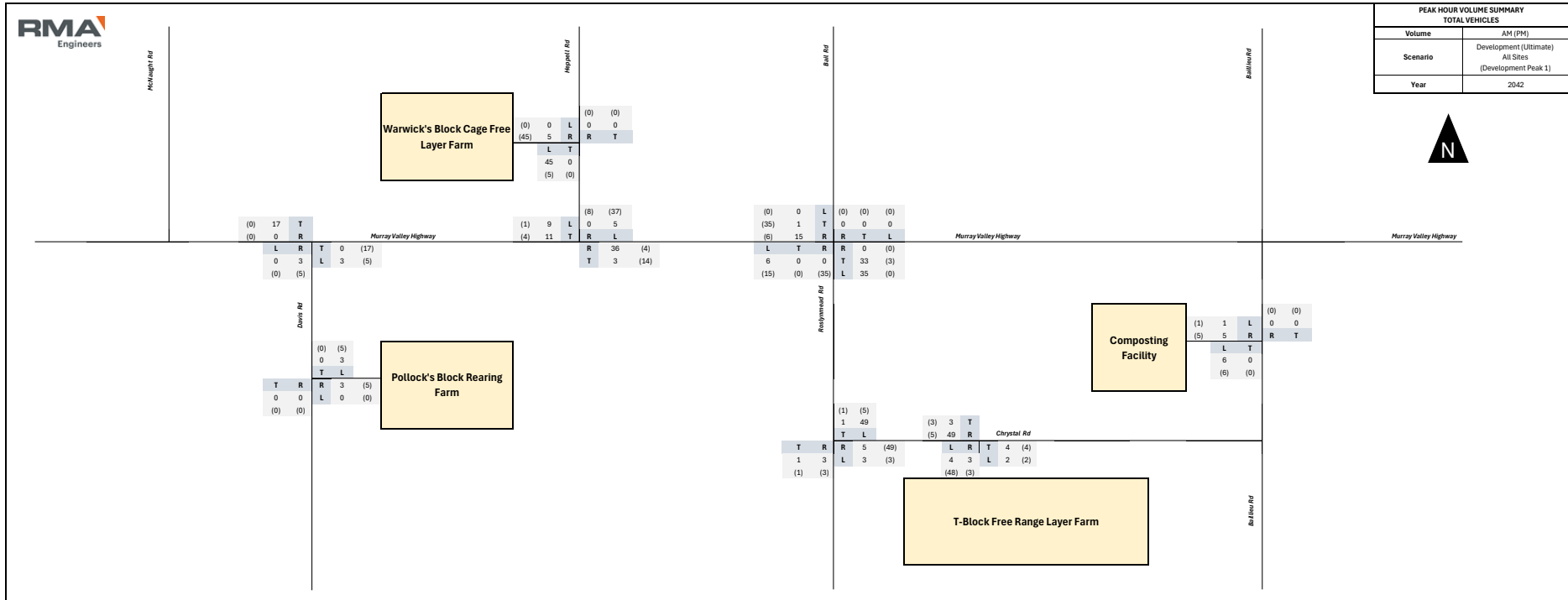

PEAK HOUR VOLUME SUMMARY TOTAL VEHICLES	
Volume	AM (PM)
Scenario	Development (Ultimate) All Sites (Development Peak 2)
Year	2042

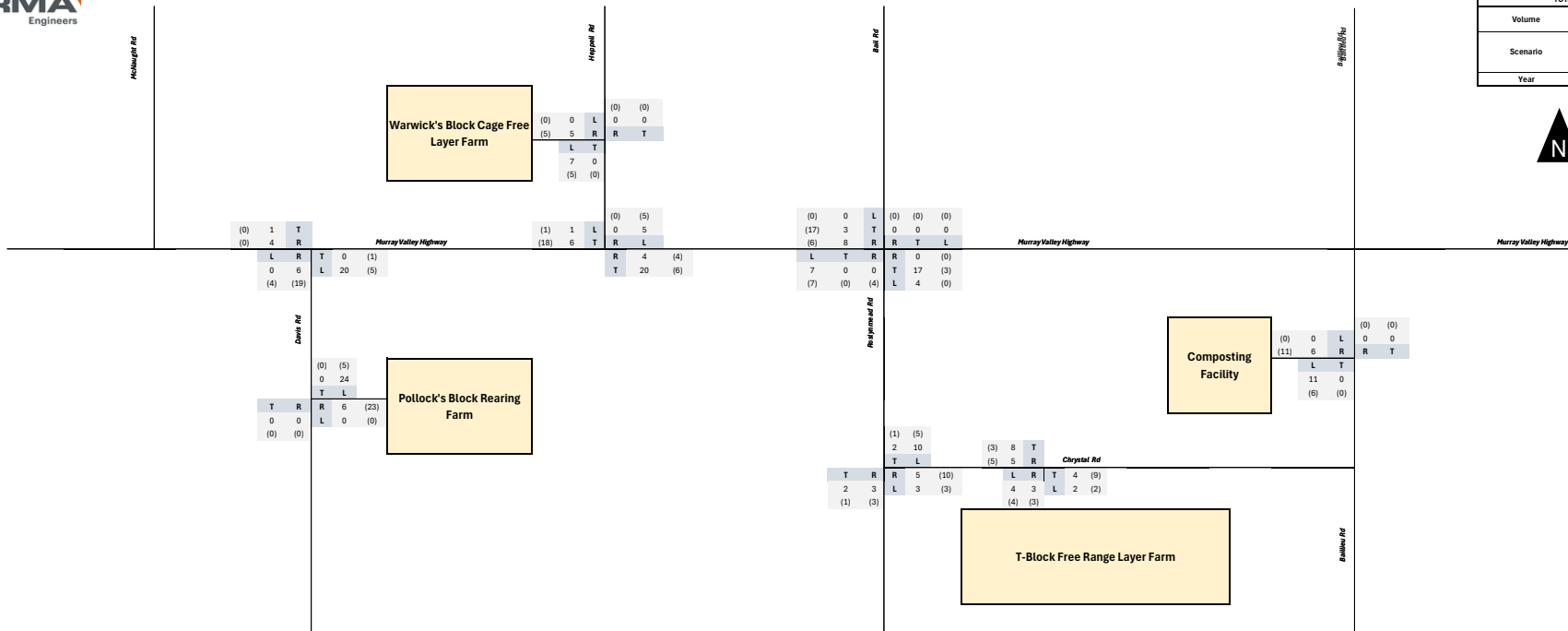

TRAFFIC VOLUME SUMMARY TOTAL VEHICLES	
Volume	Estimated Maximum Daily
Scenario	Development (Ultimate) All Sites
Year	2042

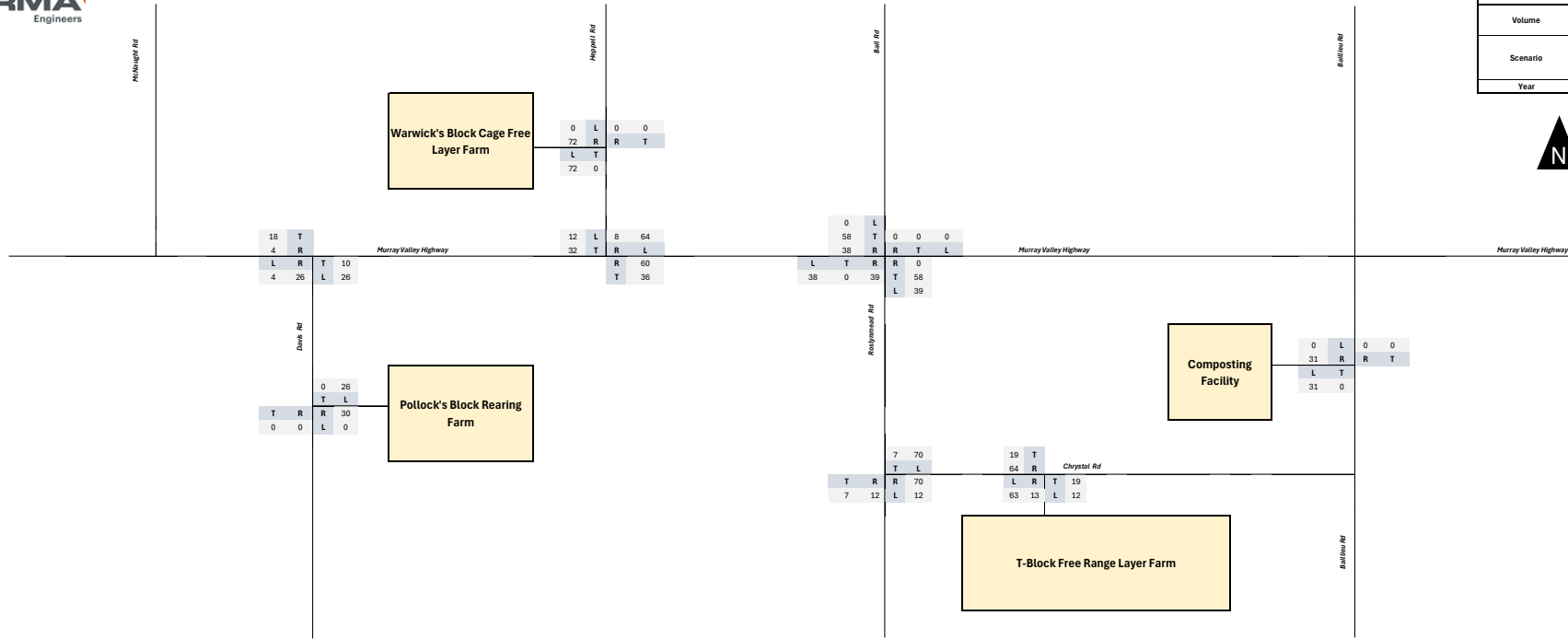

PEAK HOUR VOLUME SUMMARY LIGHT VEHICLES	
Volume	AM (PM)
Scenario	Development (Ultimate) All Sites (Network Peak)
Year	2042

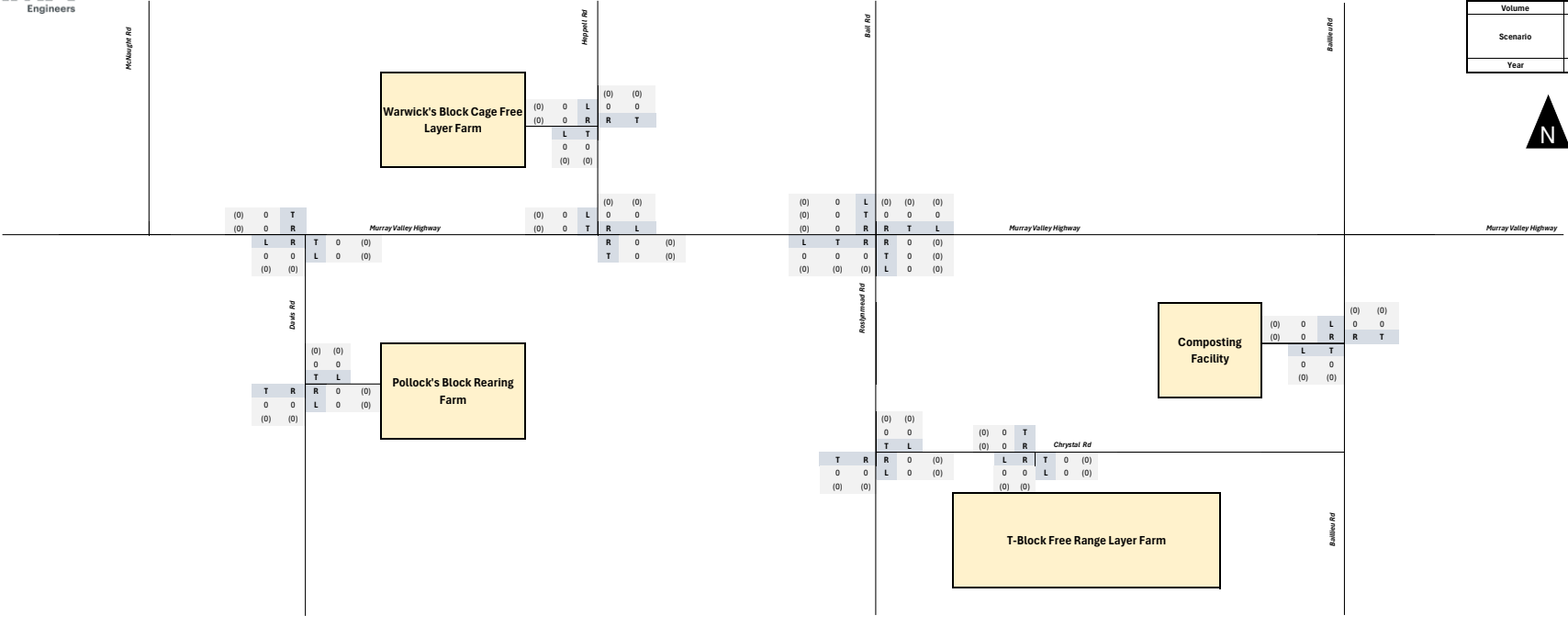

PEAK HOUR VOLUME SUMMARY	
LIGHT VEHICLES	
Volume	AM (PM)
Scenario	Development (Ultimate) All Sites (Development Peak 1)
Year	2042

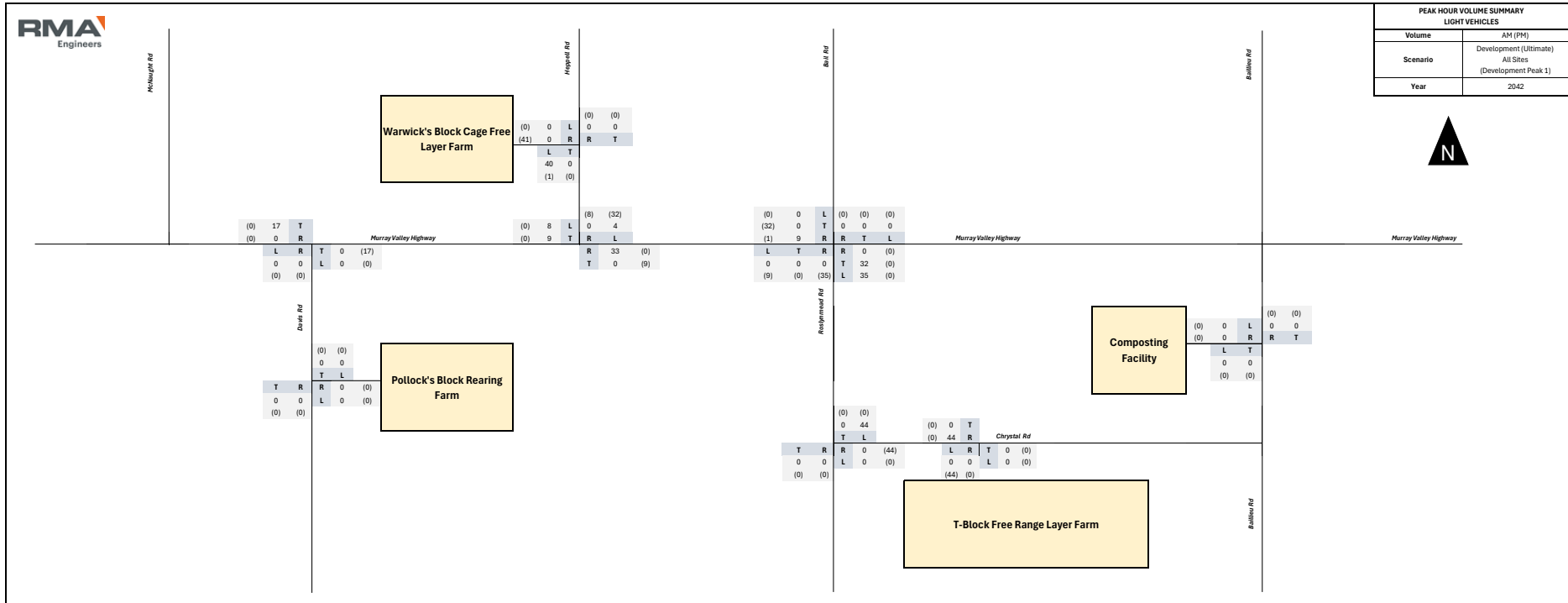

PEAK HOUR VOLUME SUMMARY	
LIGHT VEHICLES	
Volume	AM (PM)
Scenario	Development (Ultimate) All Sites (Development Peak 2)
Year	2042

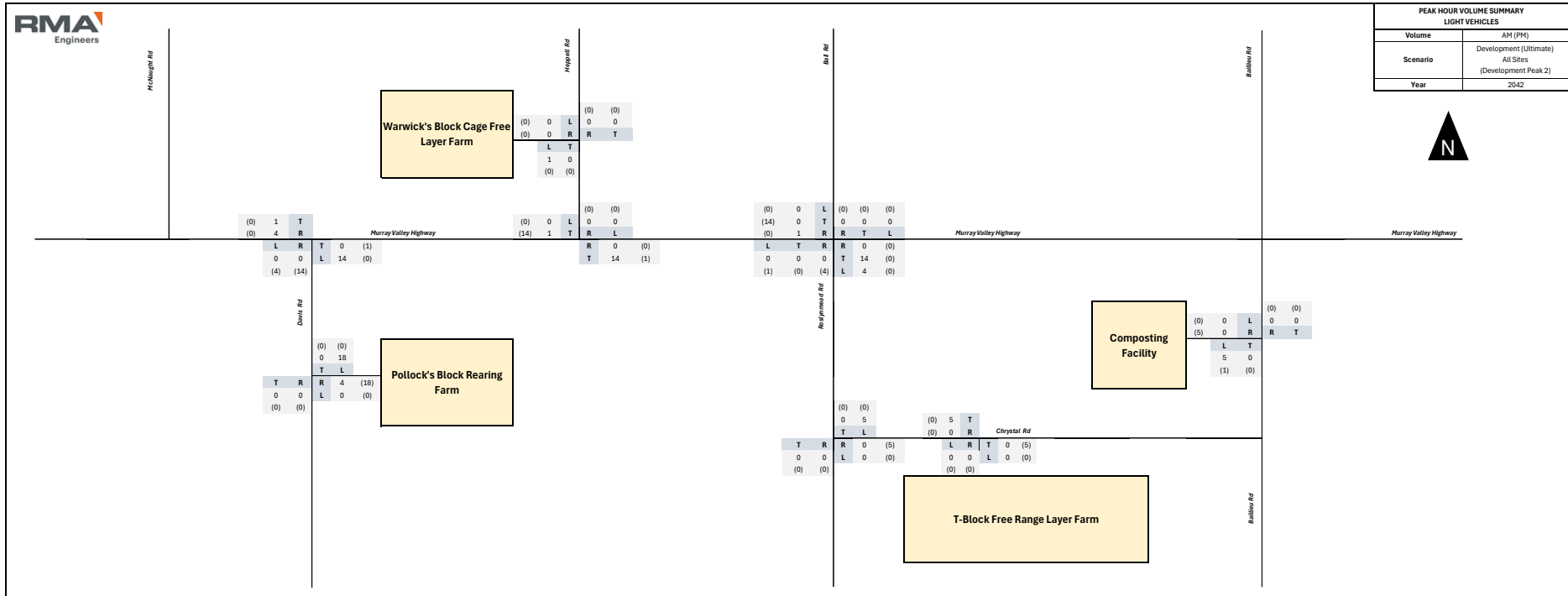

TRAFFIC VOLUME SUMMARY LIGHT VEHICLES	
Volume	Estimated Maximum Daily
Scenario	Development (Ultimate) All Sites
Year	2042

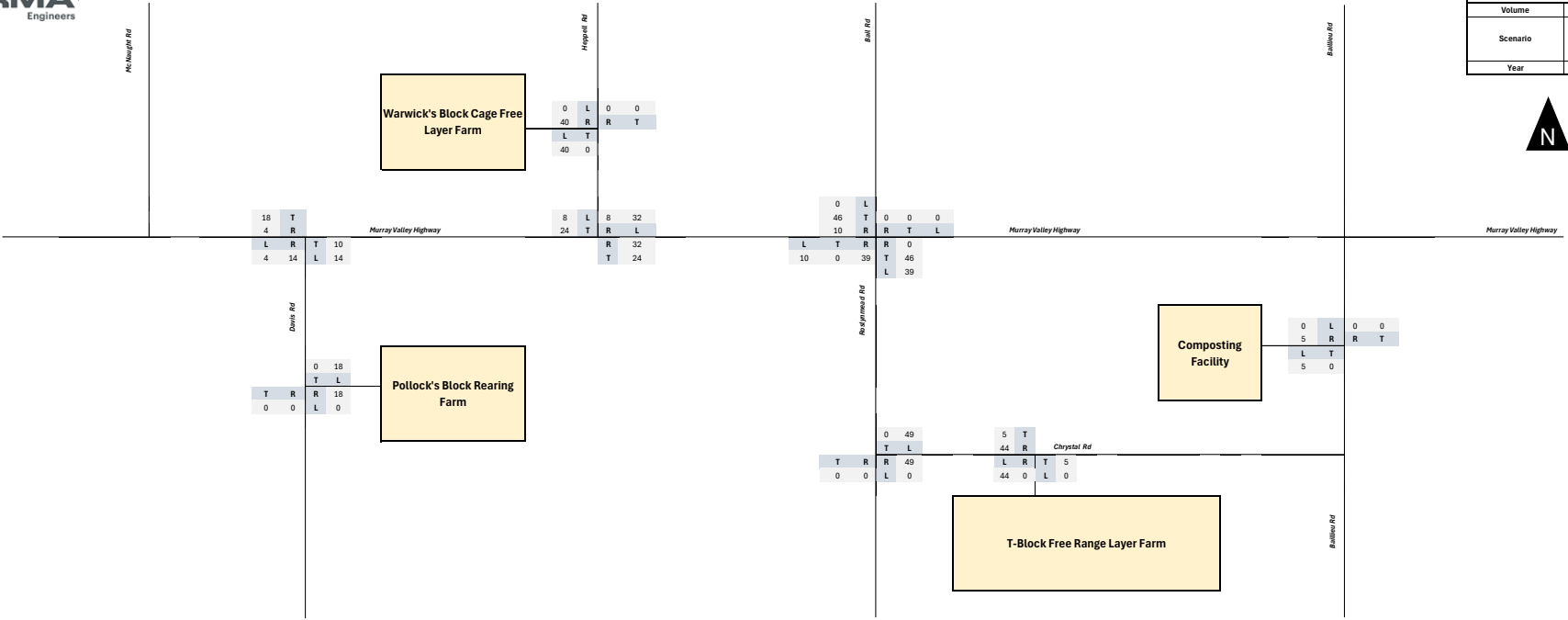

PEAK HOUR VOLUME SUMMARY HEAVY VEHICLES	
Volume	AM (PM)
Scenario	Development (Ultimate) All Sites (Network Peak)
Year	2042

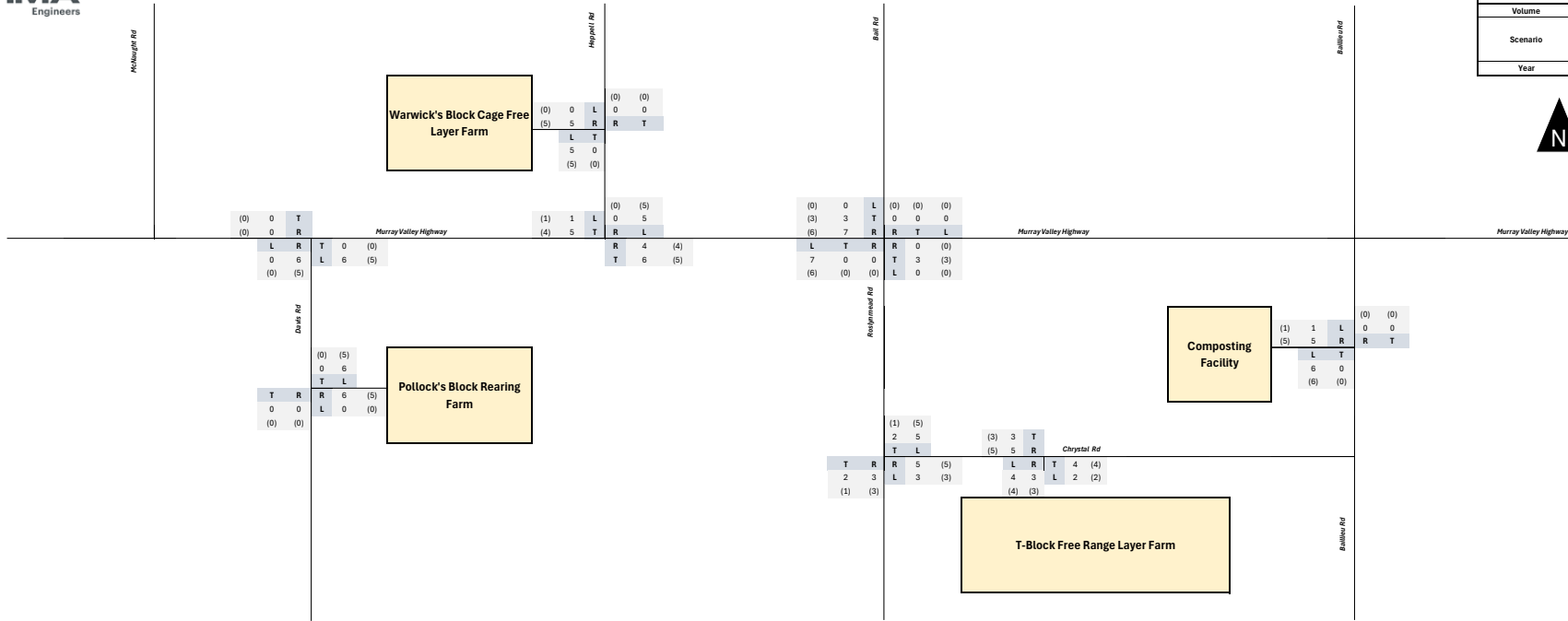

PEAK HOUR VOLUME SUMMARY	
HEAVY VEHICLES	
Volume	AM (PM)
Scenario	Development (Ultimate) All Sites (Development Peak 1)
Year	2042

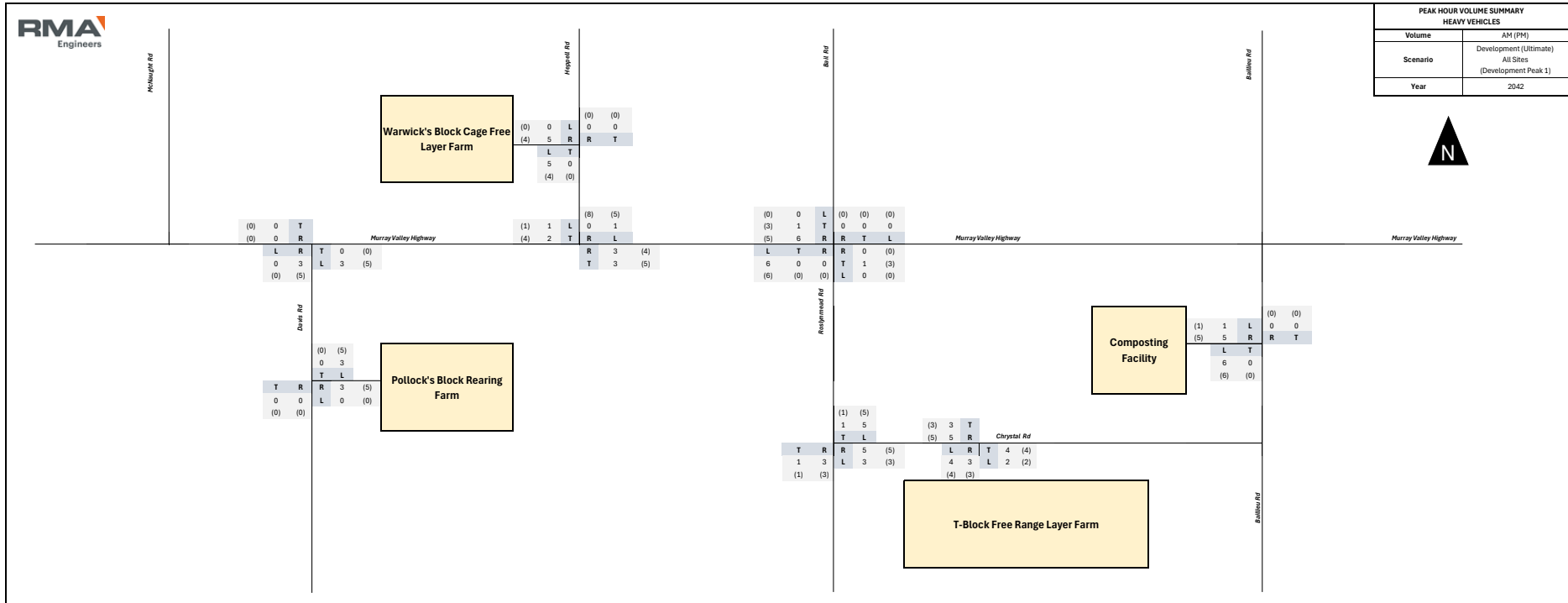

PEAK HOUR VOLUME SUMMARY	
HEAVY VEHICLES	
Volume	AM (PM)
Scenario	Development (Ultimate) All Sites (Development Peak 2)
Year	2042

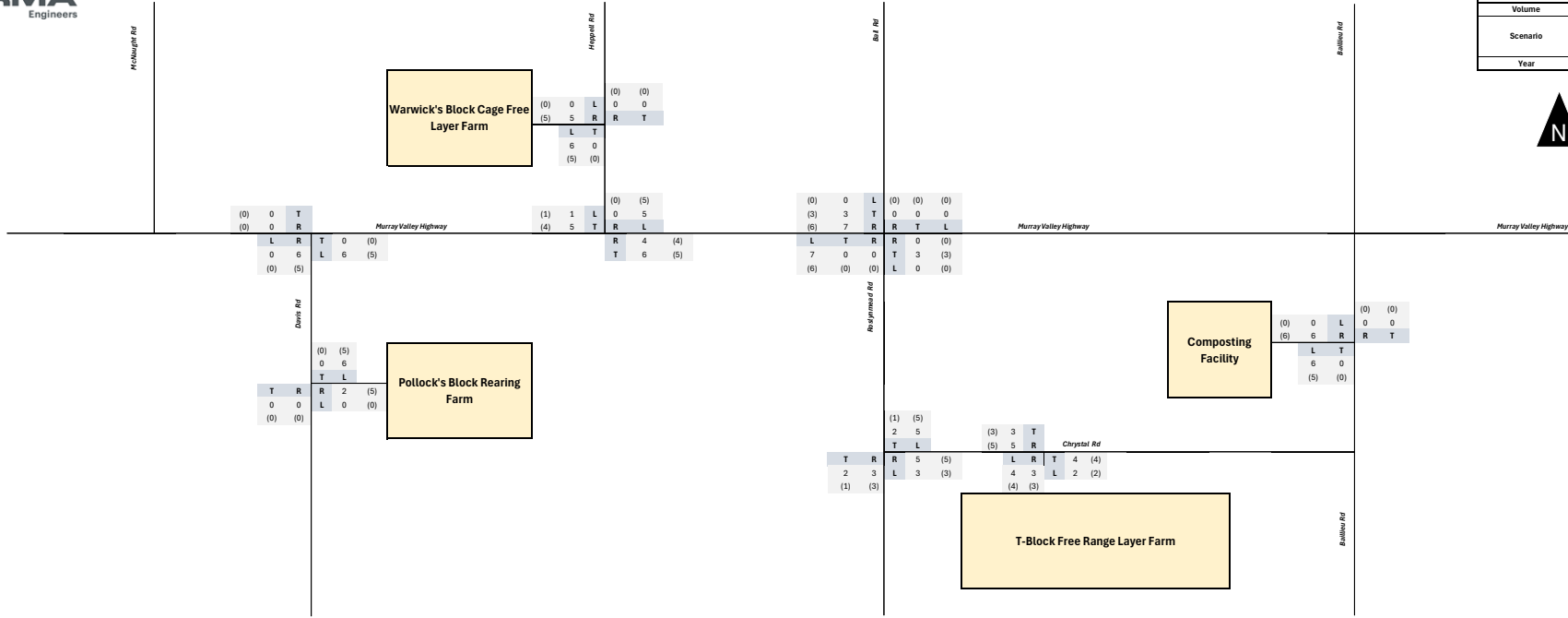

Warwick's Block Cage Free Layer Farm

(0)	0	L	(0)	(0)
(5)	5	R	0	T
		L	6	0
		T	(5)	(0)

Murray Valley Highway

(0)	0	T	(0)	(0)
(0)	0	R	0	0
L	R	T	0	(0)
0	6	L	6	(5)
(0)	(5)			

Pollock's Block Rearing Farm

(0)	(5)			
0	6			
T	L			
0	0	R	2	(5)
(0)	(0)	L	0	(0)

Murray Valley Highway

(0)	0	L	(0)	(0)	(0)
(3)	3	T	0	0	0
(6)	7	R	R	T	L
			0	0	(0)
L	T	R	0	0	(0)
7	0	0	T	3	(3)
(6)	(0)	(0)	L	0	(0)

Crystal Rd

(1)	(5)			
2	5			
T	L			
5	5	R	4	(4)
(1)	(5)	L	3	(3)
2	3			
L	R	T	4	(4)
(4)	(3)	L	2	(2)

Composting Facility

(0)	0	L	(0)	(0)
(6)	6	R	0	T
		L	6	0
		T	(5)	(0)

TRAFFIC VOLUME SUMMARY HEAVY VEHICLES	
Volume	Estimated Maximum Daily
Scenario	Development (Ultimate) All Sites
Year	2042

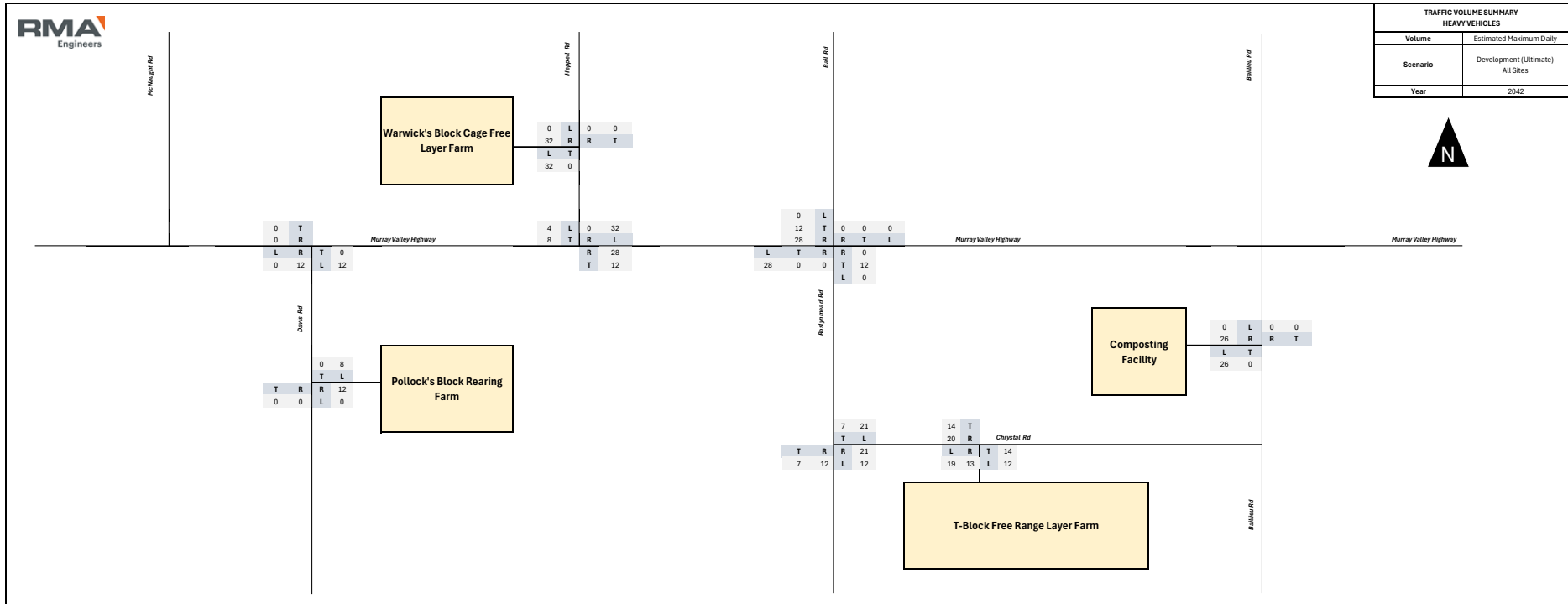

PEAK HOUR VOLUME SUMMARY TOTAL VEHICLES	
Volume	AM (PM)
Scenario	Background & Development (Network Peak)
Year	2042

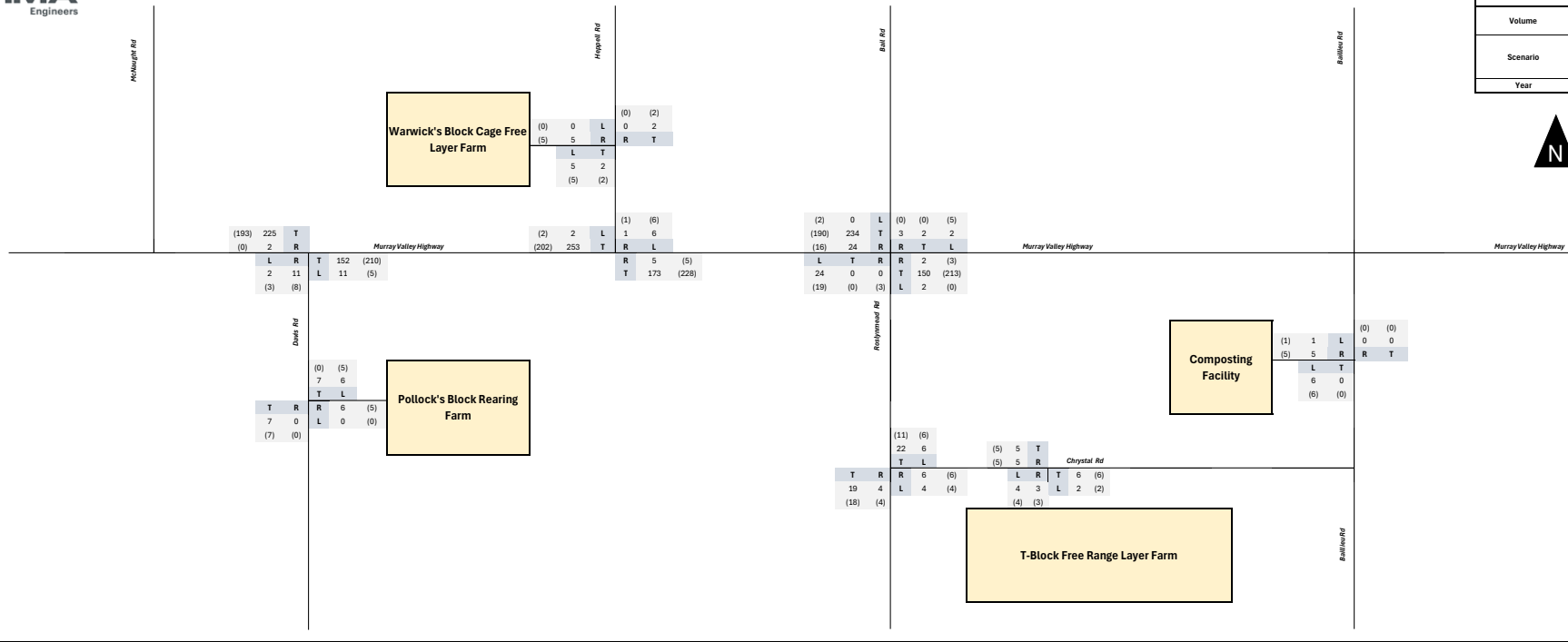

PEAK HOUR VOLUME SUMMARY TOTAL VEHICLES	
Volume	AM (PM)
Scenario	Background & Development (Development Peak 1)
Year	2042

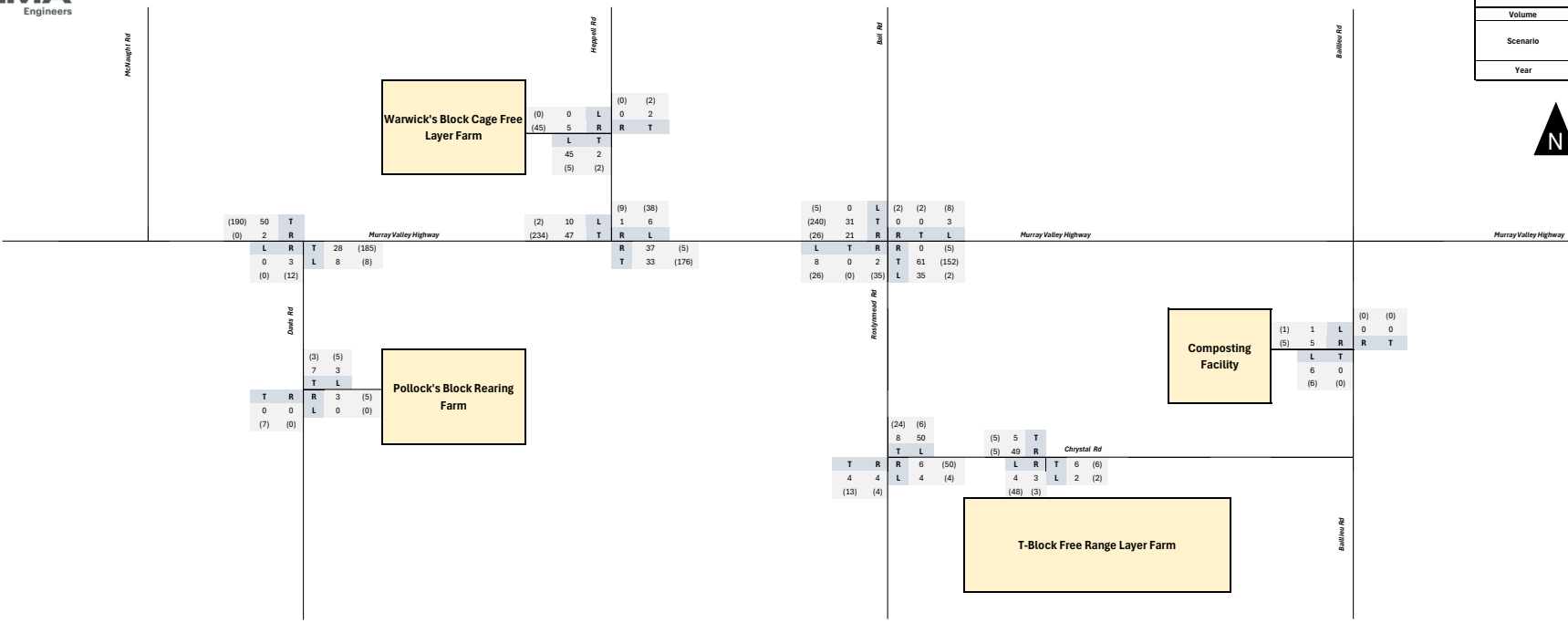

PEAK HOUR VOLUME SUMMARY TOTAL VEHICLES	
Volume	AM (PM)
Scenario	Background & Development (Development Peak 2)
Year	2042

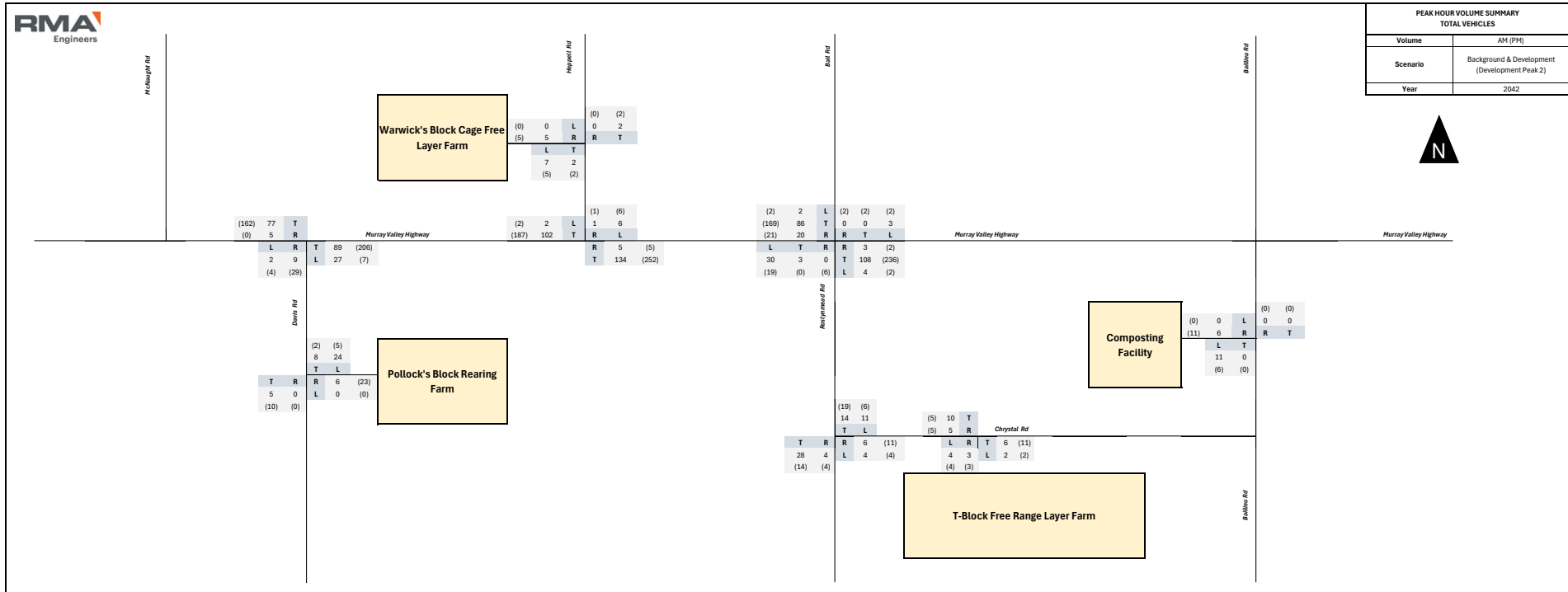

TRAFFIC VOLUME SUMMARY	
TOTAL VEHICLES	
Volume	Daily
Scenario	Background & Development
Year	2042

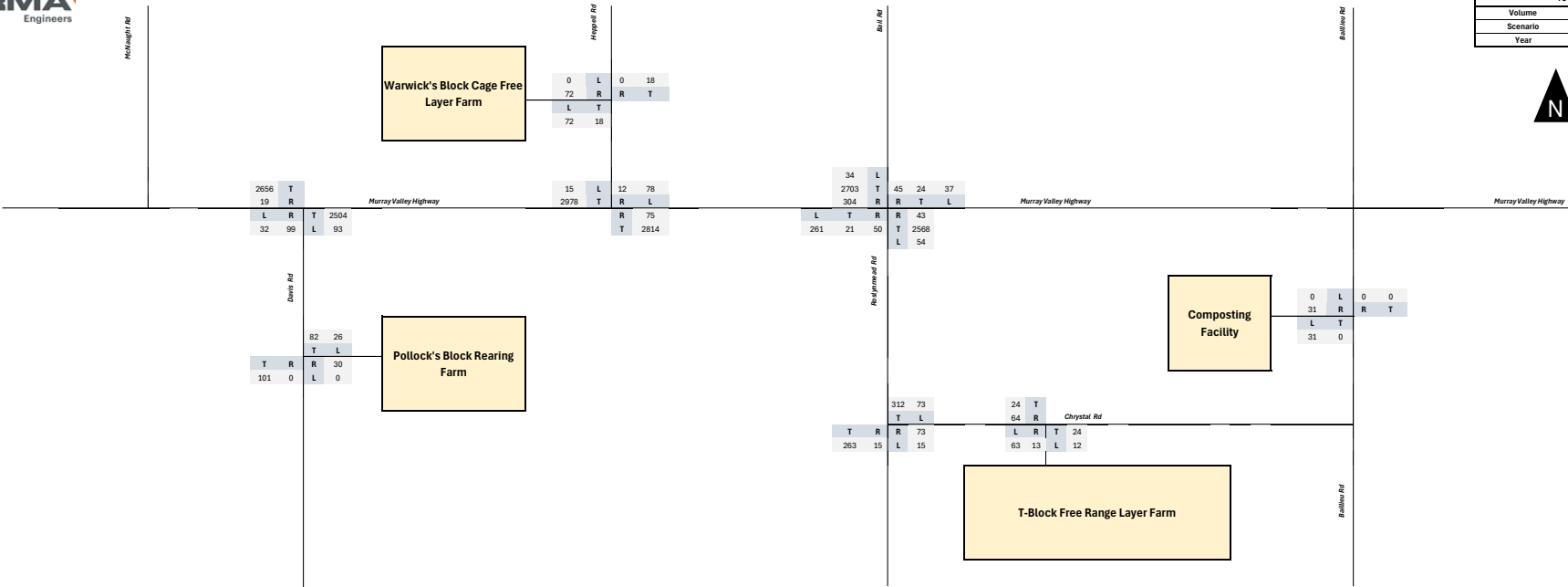

PEAK HOUR VOLUME SUMMARY LIGHT VEHICLES	
Volume	AM (PM)
Scenario	Background & Development (Network Peak)
Year	2042

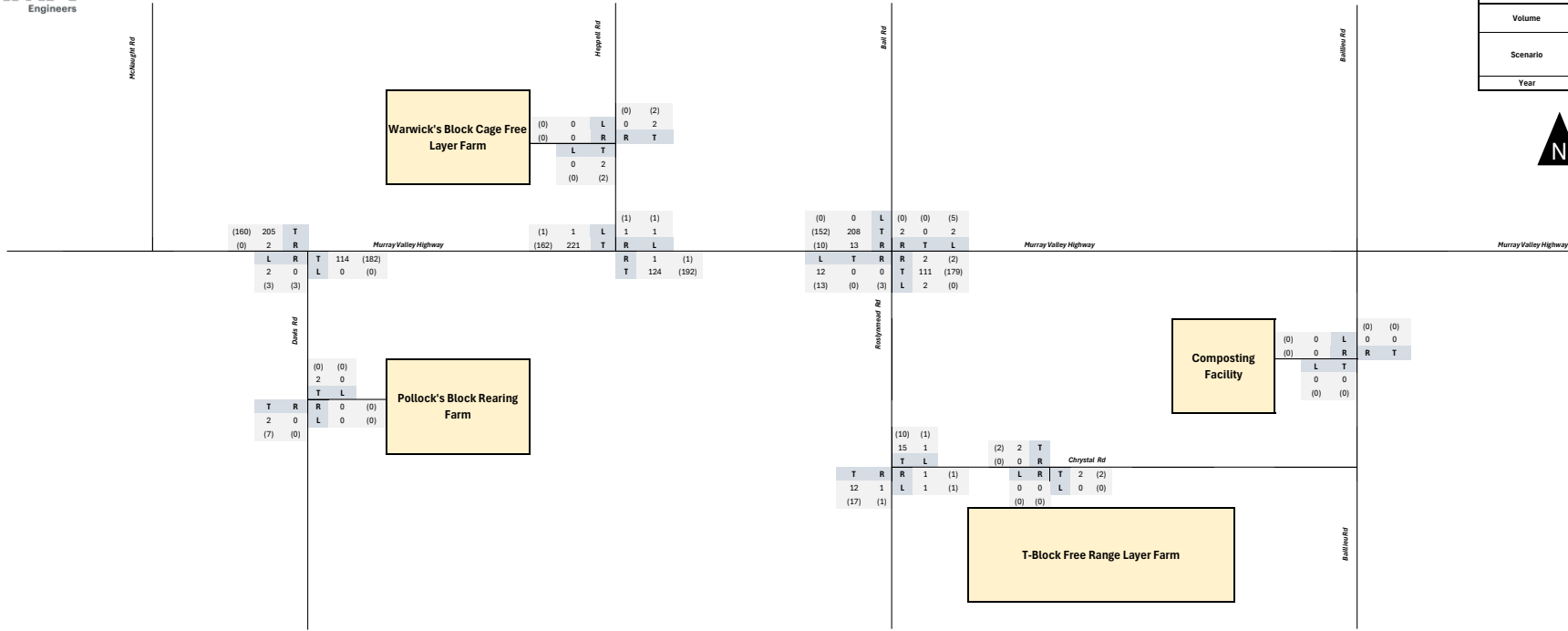

PEAK HOUR VOLUME SUMMARY LIGHT VEHICLES	
Volume	AM (PM)
Scenario	Background & Development (Development Peak 1)
Year	2042

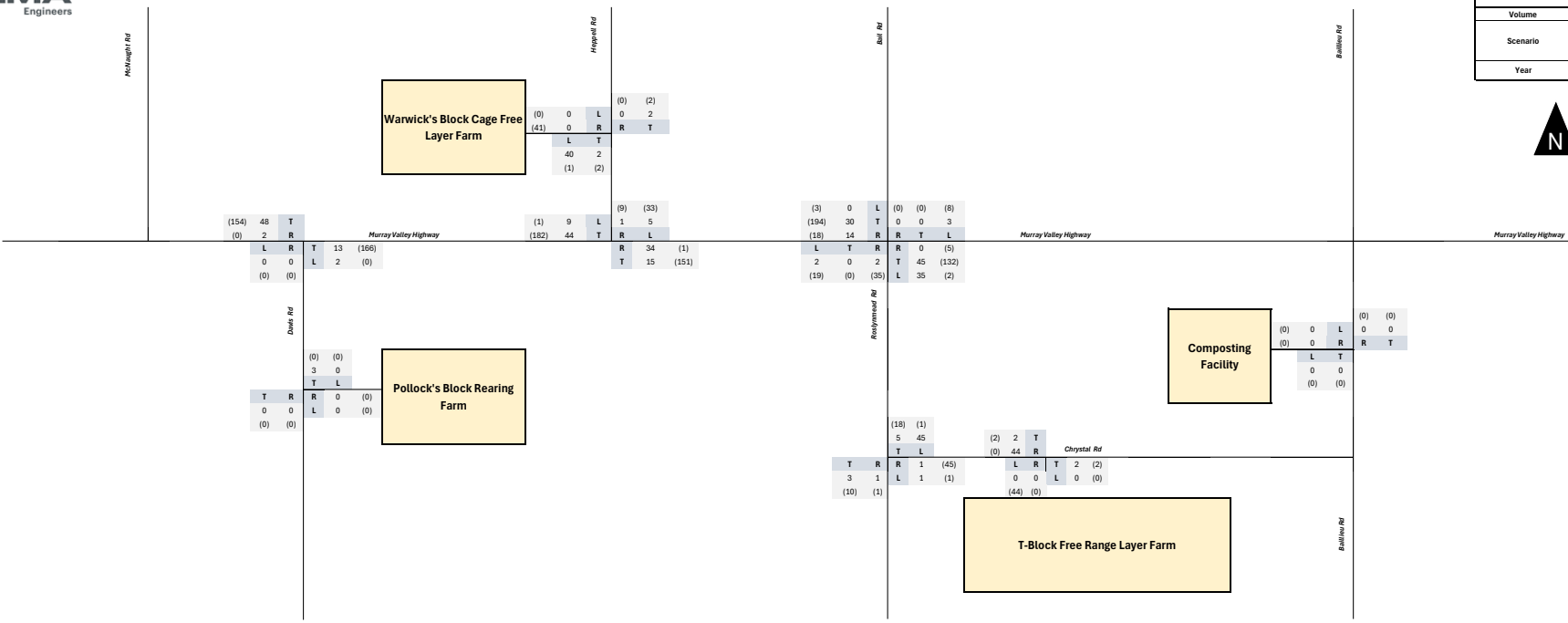

PEAK HOUR VOLUME SUMMARY	
LIGHT VEHICLES	
Volume	AM (PM)
Scenario	Background & Development (Development Peak 2)
Year	2042

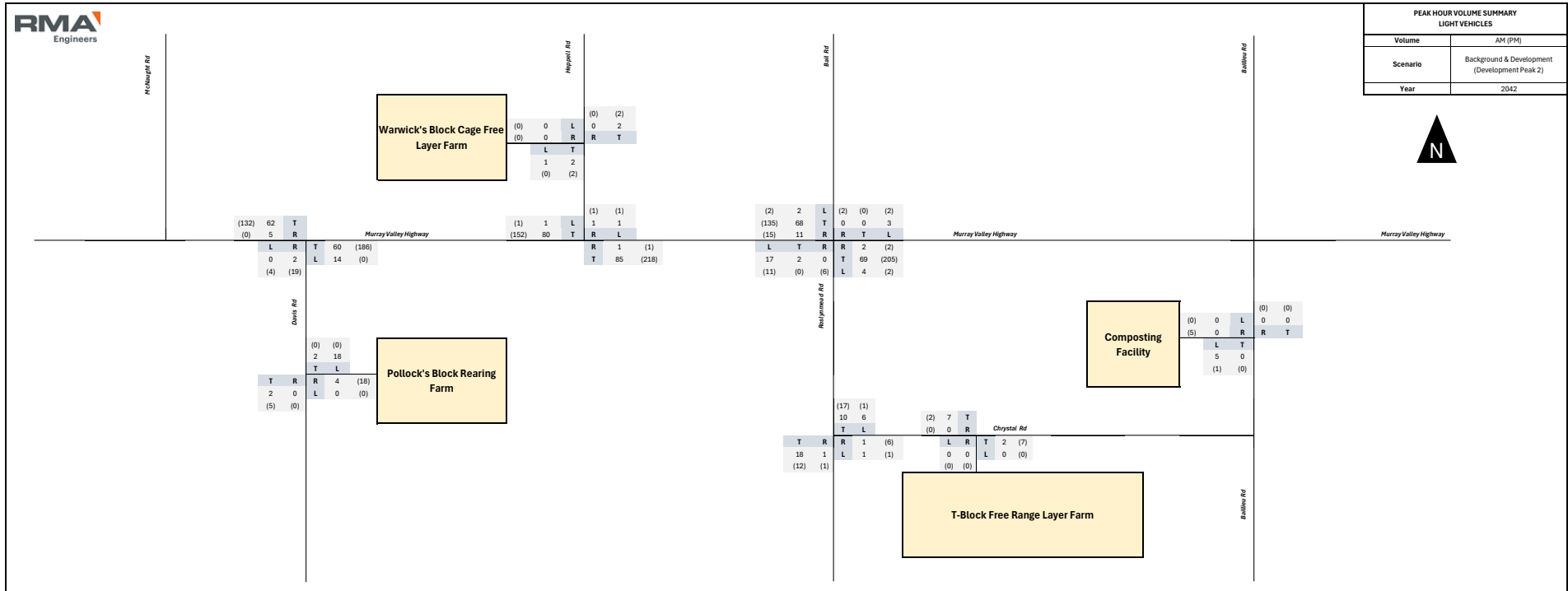

TRAFFIC VOLUME SUMMARY	
LIGHT VEHICLES	
Volume	Daily
Scenario	Background & Development
Year	2042

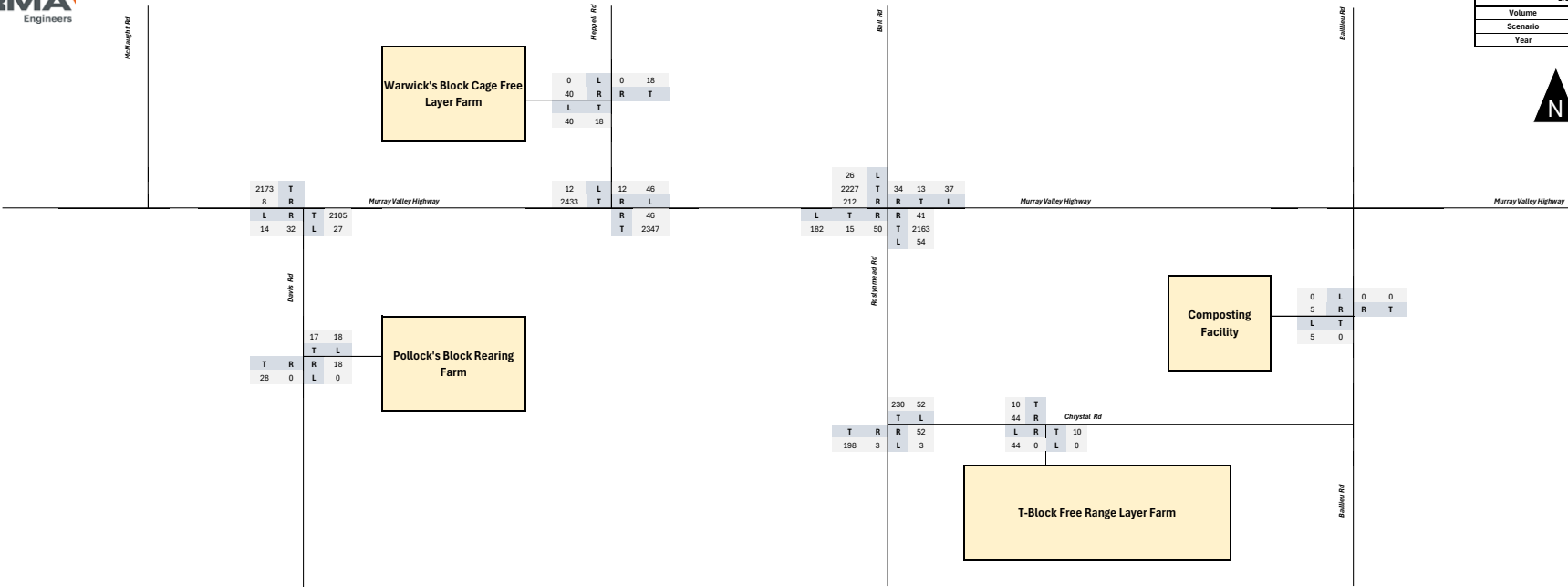

PEAK HOUR VOLUME SUMMARY HEAVY VEHICLES	
Volume	AM (PM)
Scenario	Background & Development (Network Peak)
Year	2042

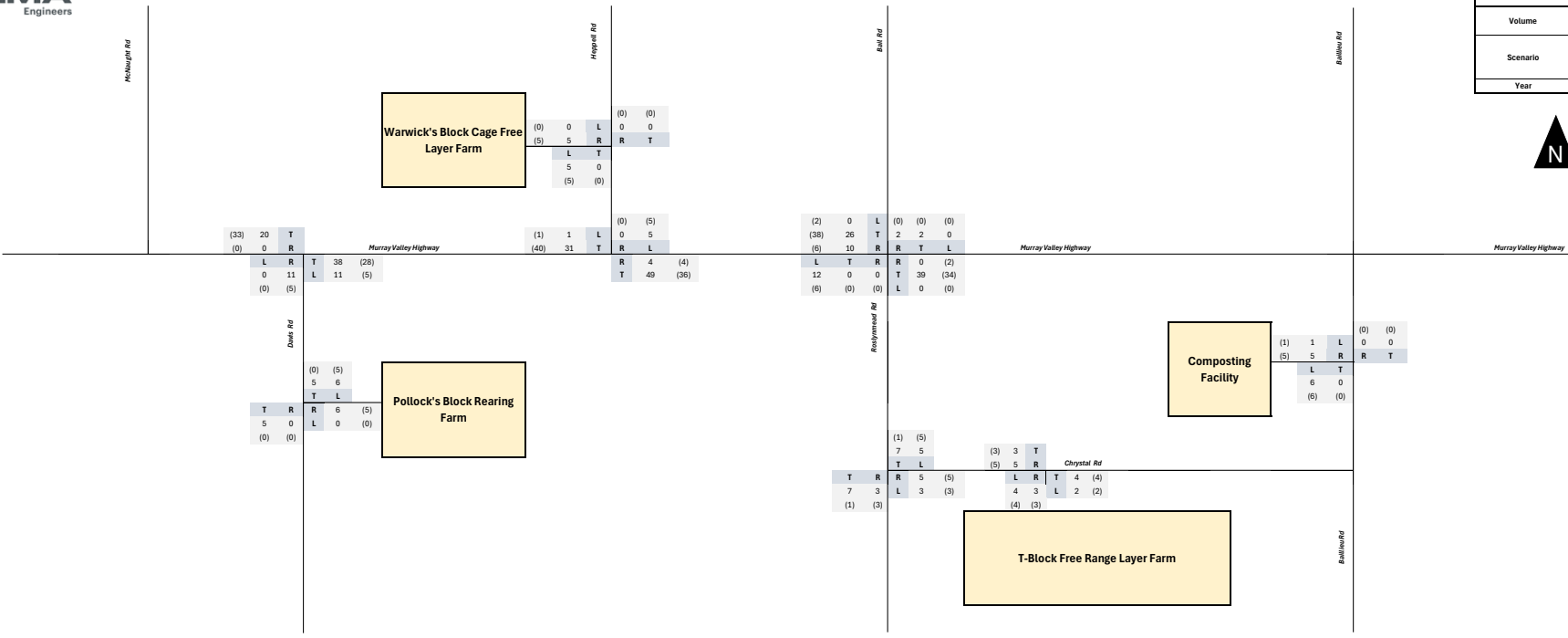

PEAK HOUR VOLUME SUMMARY HEAVY VEHICLES	
Volume	AM (PM)
Scenario	Background & Development (Development Peak 1)
Year	2042

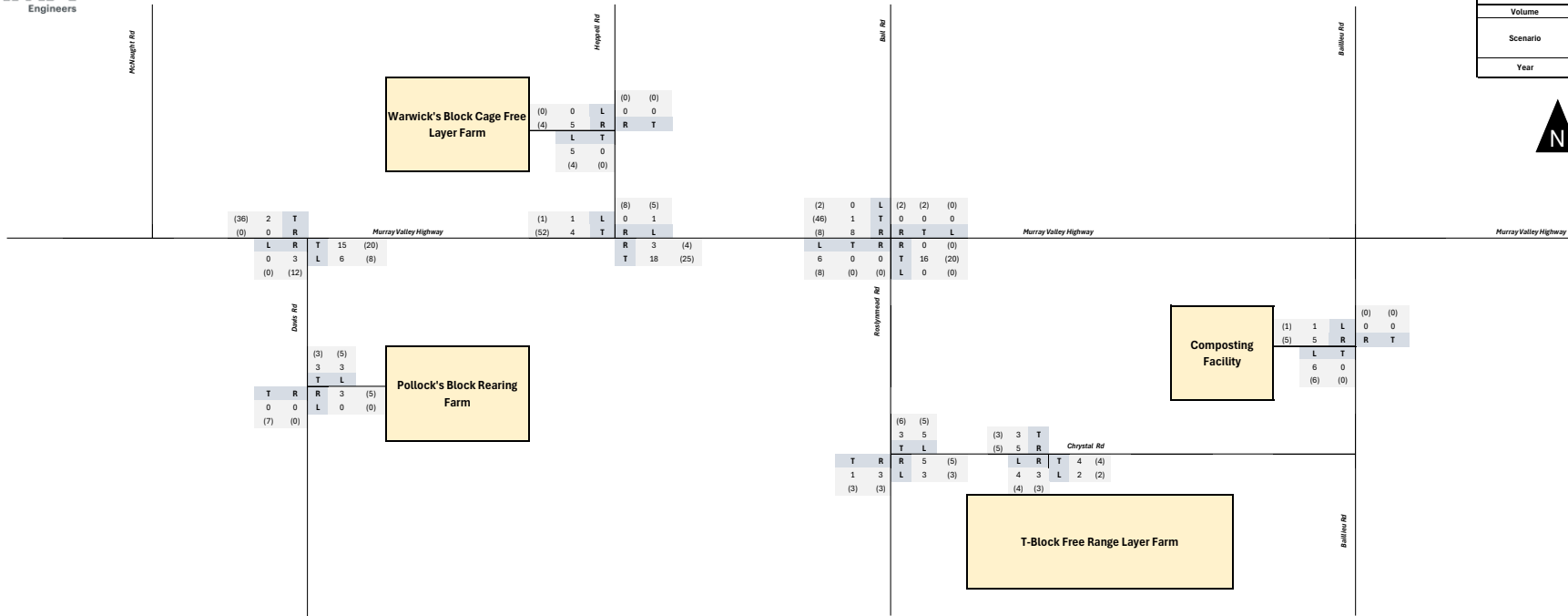

PEAK HOUR VOLUME SUMMARY HEAVY VEHICLES	
Volume	AM (PM)
Scenario	Background & Development (Development Peak 2)
Year	2042

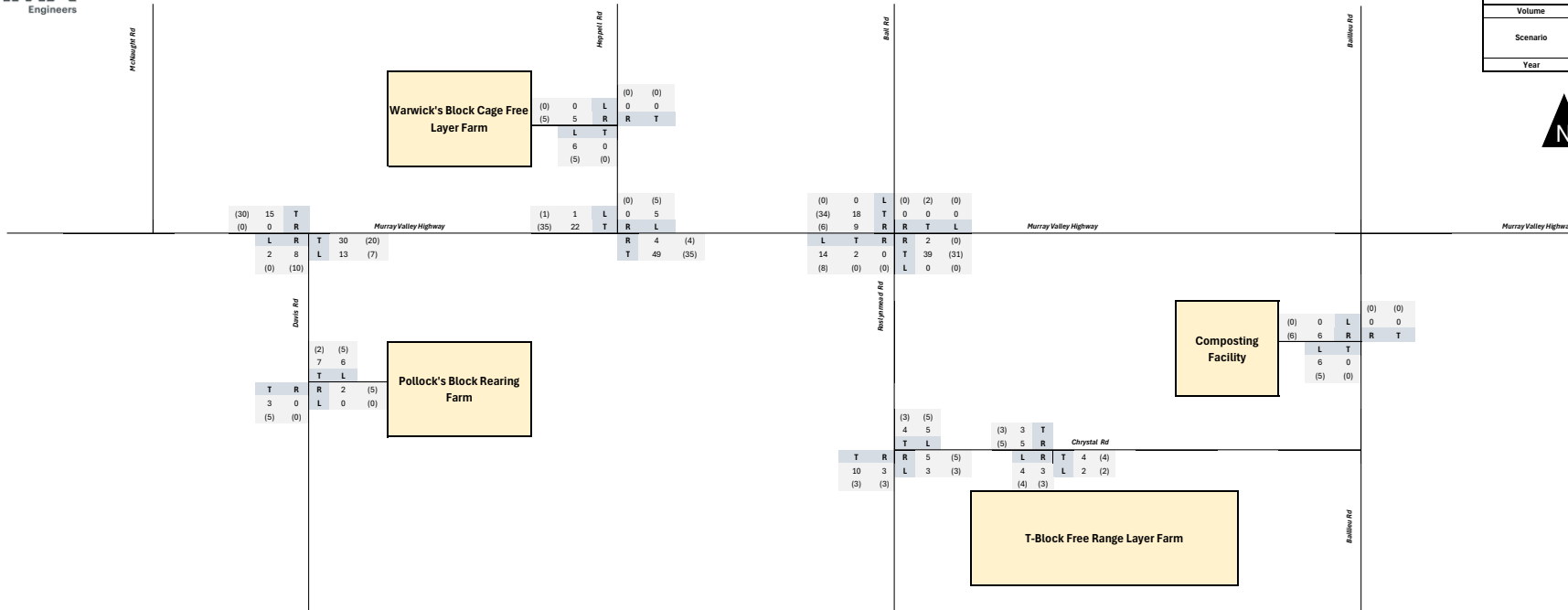

TRAFFIC VOLUME SUMMARY	
HEAVY VEHICLES	
Volume	Daily
Scenario	Background & Development
Year	2042

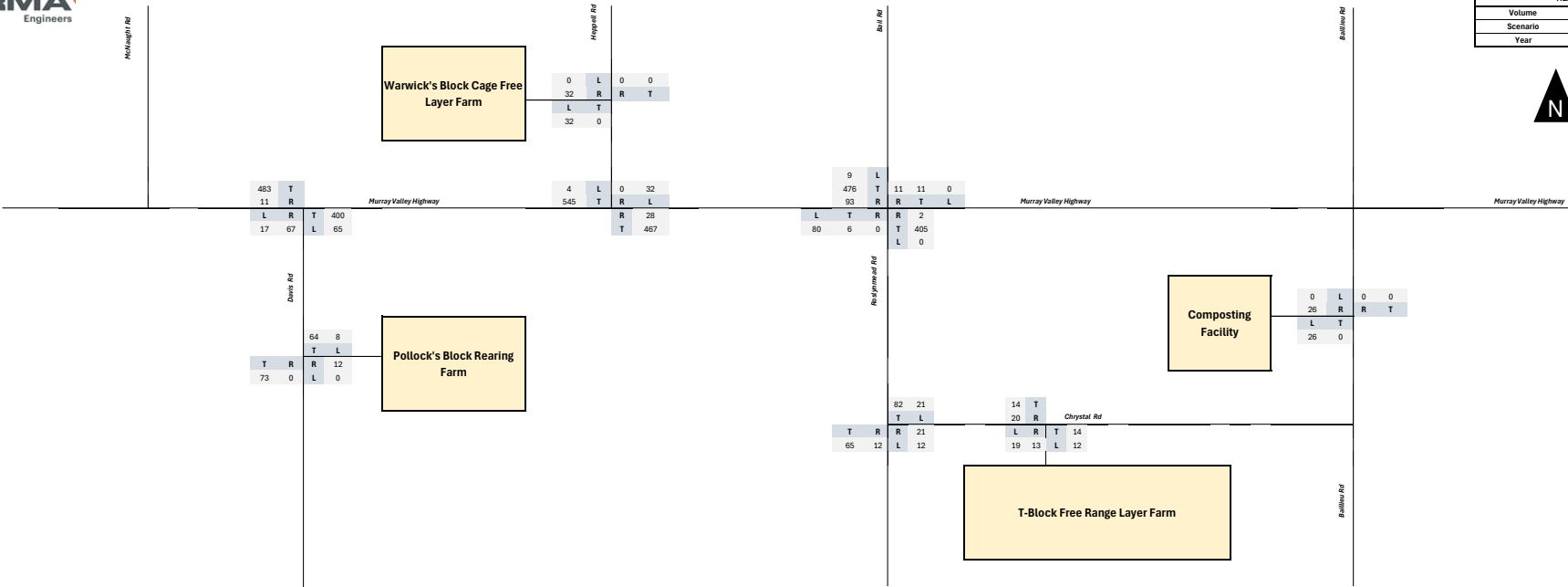

PEAK HOUR VOLUME SUMMARY TOTAL VEHICLES	
Volume	AM (PM)
Scenario	Background & Development (Network Peak)
Year	2052

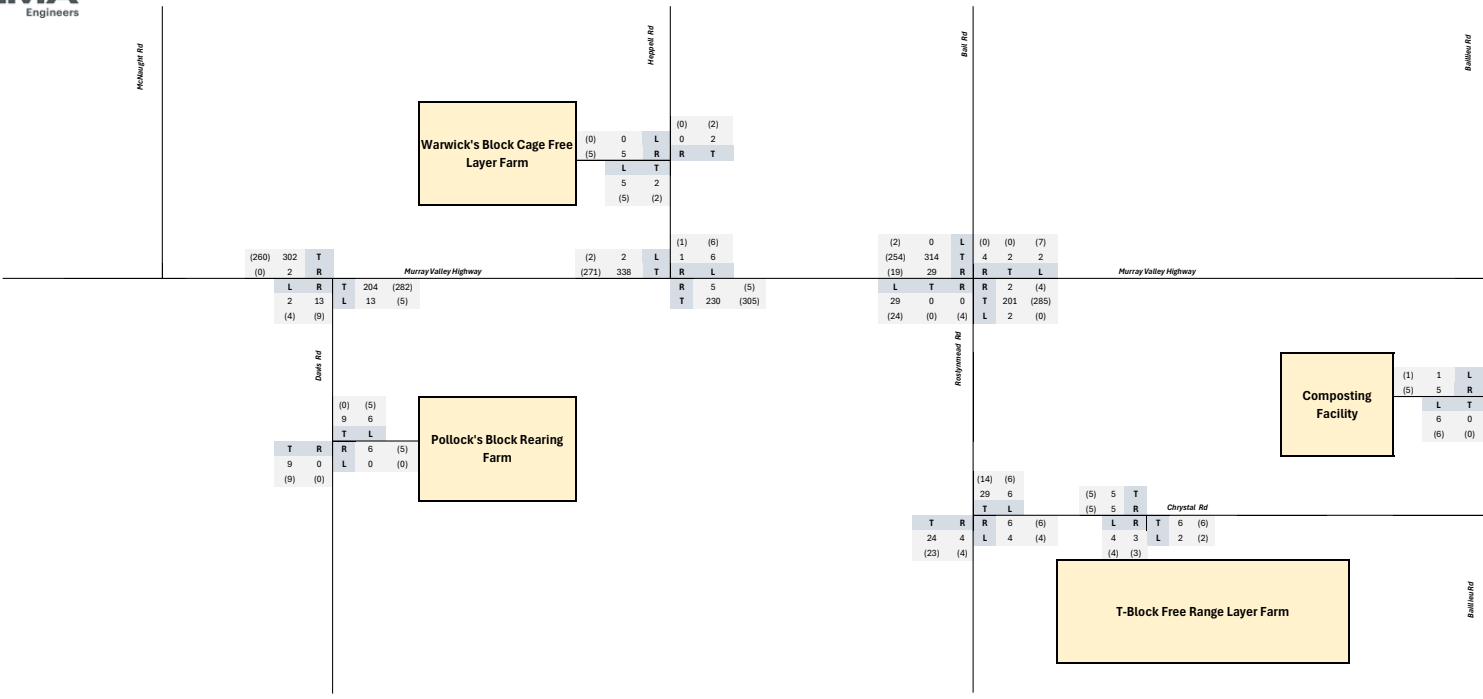

(260)	302	T
(0)	2	R
	L	R
	2	13
	(4)	(9)

(0)	0	L
(5)	5	R
	L	T
	5	2
	(5)	(2)

(2)	2	L
(271)	338	T
	R	L
	5	(5)
	T	230
		(305)

(2)	0	L
(254)	314	T
(19)	29	R
	L	T
	29	0
	(24)	(0)

(0)	(5)
9	6
T	L
R	6
L	0
(9)	(0)

R	6	(5)
L	0	(0)

(14)	(6)
29	6
T	L
R	6
L	4
(23)	(4)

(5)	5	T
(9)	5	R
	L	R
	4	3
	(4)	(3)

(1)	1	L
(5)	5	R
	L	T
	6	0
	(6)	(0)

(0)	(0)
0	0
R	T

PEAK HOUR VOLUME SUMMARY TOTAL VEHICLES	
Volume	AM (PM)
Scenario	Background & Development (Development Peak 1)
Year	2052

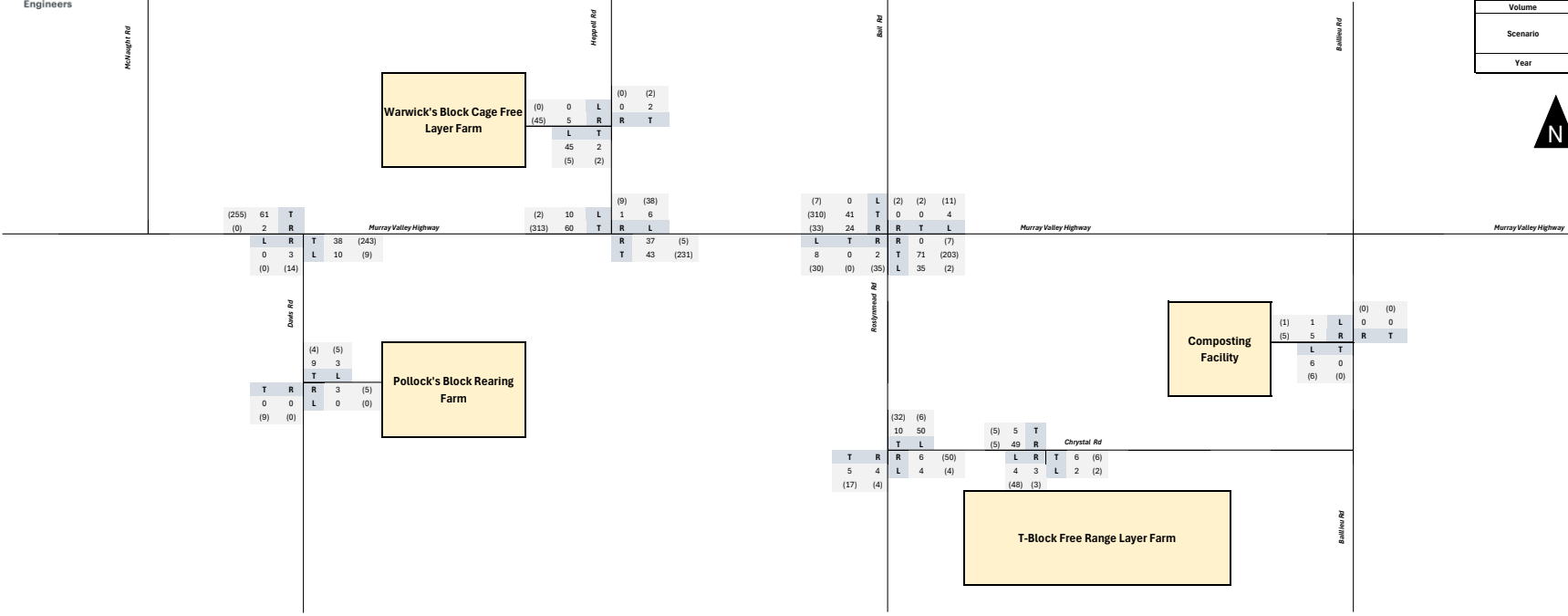

PEAK HOUR VOLUME SUMMARY	
TOTAL VEHICLES	
Volume	AM (PM)
Scenario	Background & Development (Development Peak 2)
Year	2052

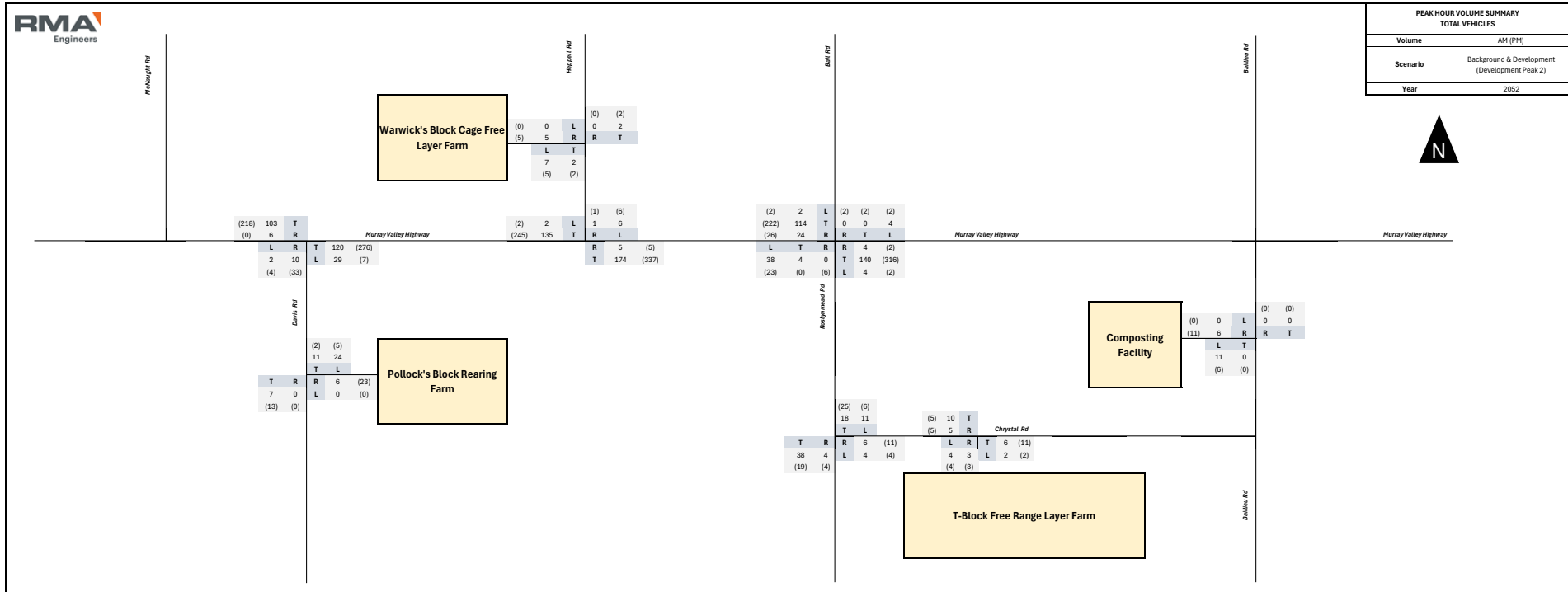

TRAFFIC VOLUME SUMMARY	
TOTAL VEHICLES	
Volume	Daily
Scenario	Background & Development
Year	2062

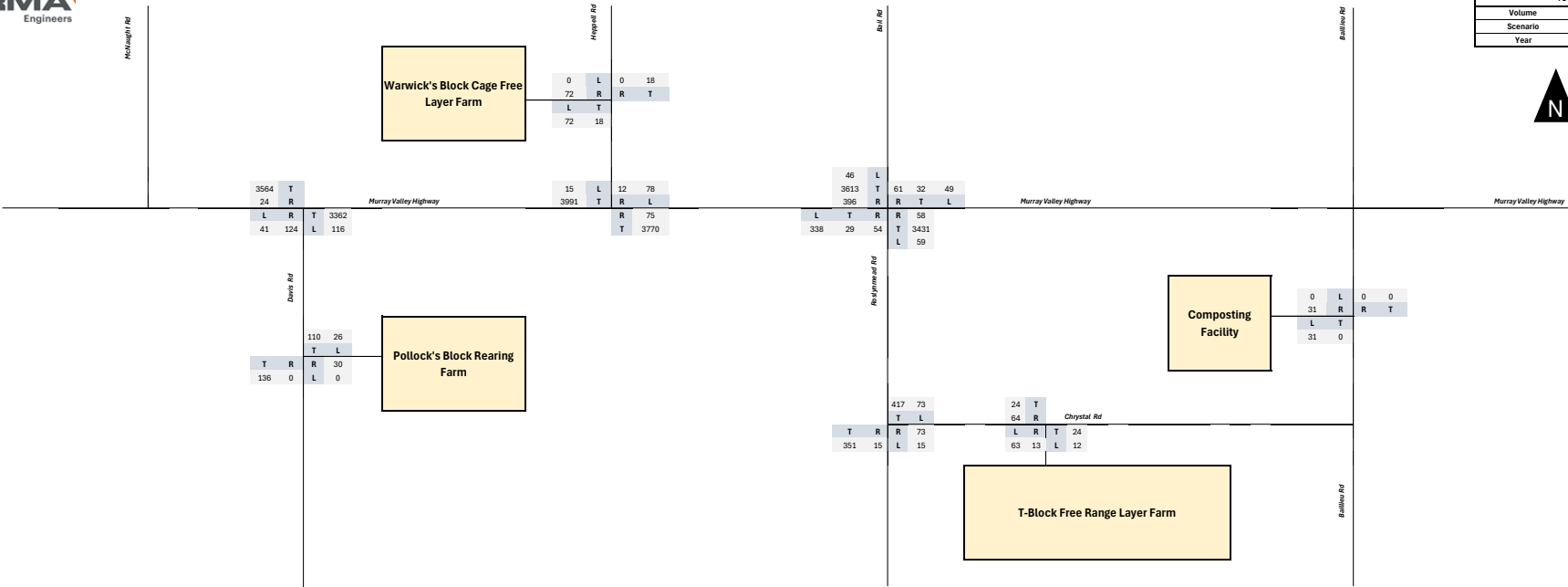

PEAK HOUR VOLUME SUMMARY LIGHT VEHICLES	
Volume	AM (PM)
Scenario	Background & Development (Network Peak)
Year	2052

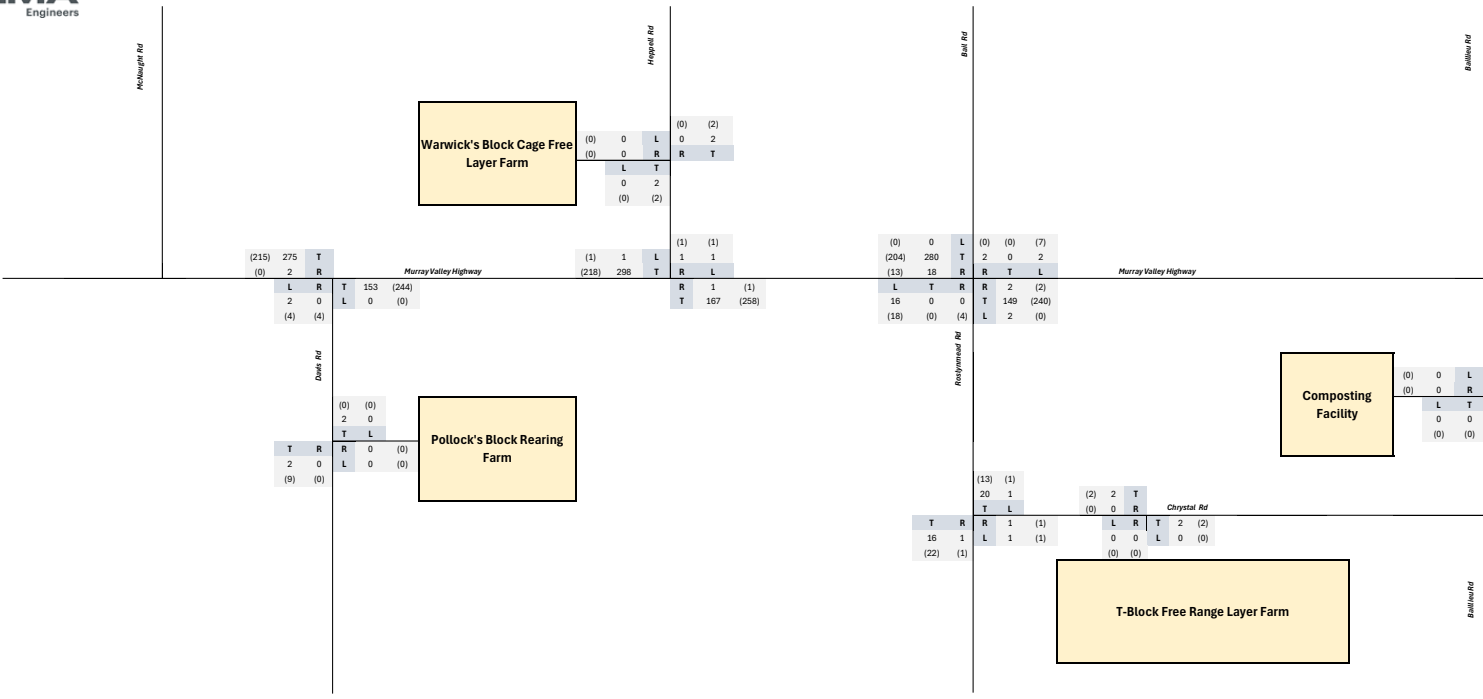

(215)	275	T
(0)	2	R
	L	R
	2	0
	(4)	(4)

T	153	(244)
L	0	(0)

(1)	1	L
(218)	298	T
	R	L
	1	(1)
	167	(256)

(0)	0	L
(204)	280	T
(15)	18	R
	R	T
	2	(2)
	16	0
	(18)	(0)

(0)	(0)	(7)
2	0	2
R	T	L
2	(2)	
T	149	(240)
L	2	(0)

(0)	(0)
2	0
T	L
R	0
L	0

R	0	(0)
L	0	(0)

(13)	(1)
20	1
T	L
R	1
L	1

(2)	2	T
(0)	0	R
L	R	T
0	0	L
0	0	0

(0)	(0)	L
(0)	0	R
L	T	R
0	0	T
(0)	(0)	L

T-Block Free Range Layer Farm

PEAK HOUR VOLUME SUMMARY LIGHT VEHICLES	
Volume	AM (PM)
Scenario	Background & Development (Development Peak 1)
Year	2052

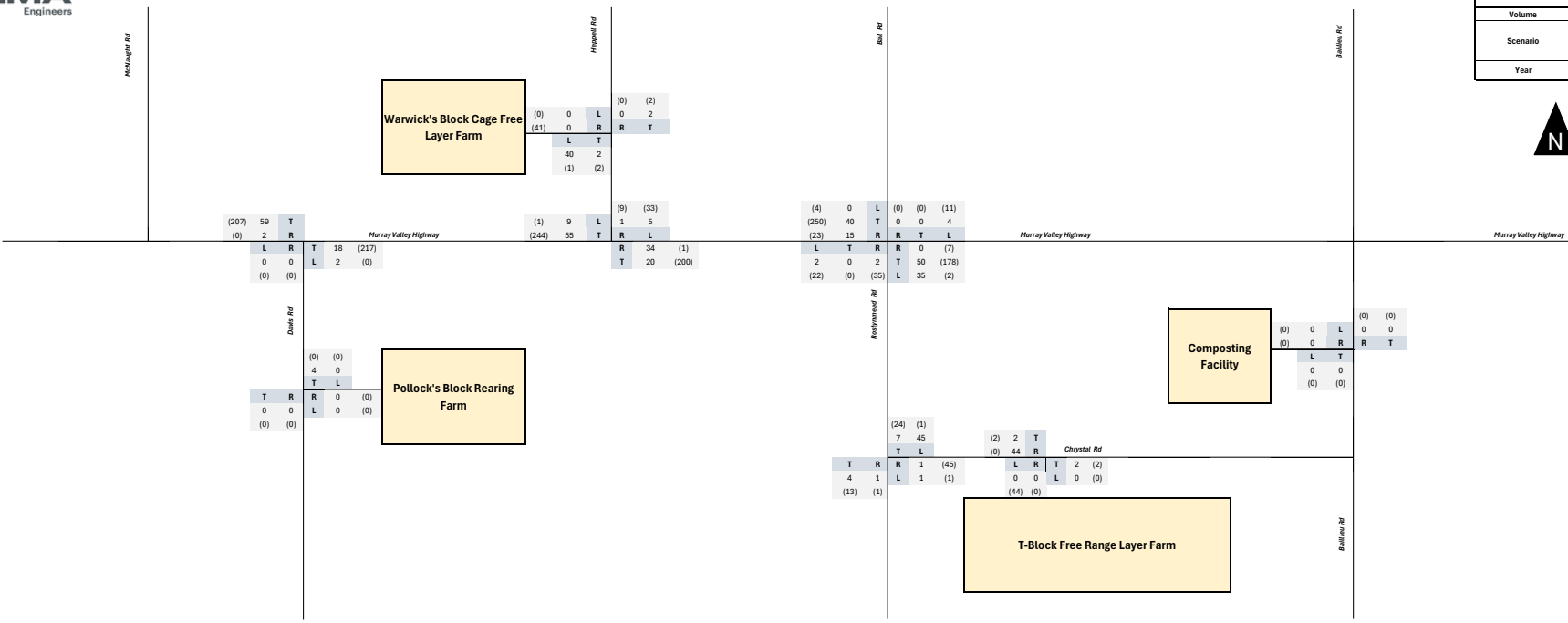

PEAK HOUR VOLUME SUMMARY	
LIGHT VEHICLES	
Volume	AM (PM)
Scenario	Background & Development (Development Peak 2)
Year	2052

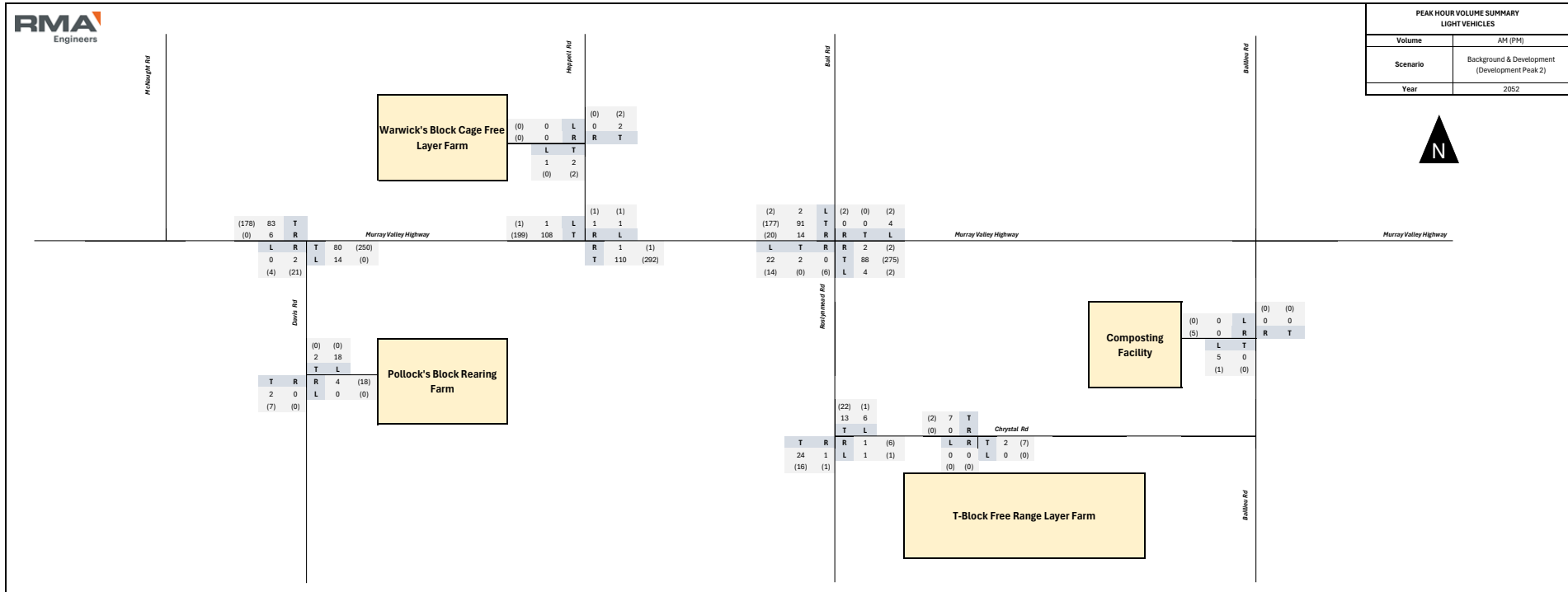

TRAFFIC VOLUME SUMMARY	
LIGHT VEHICLES	
Volume	Daily
Scenario	Background & Development
Year	2062

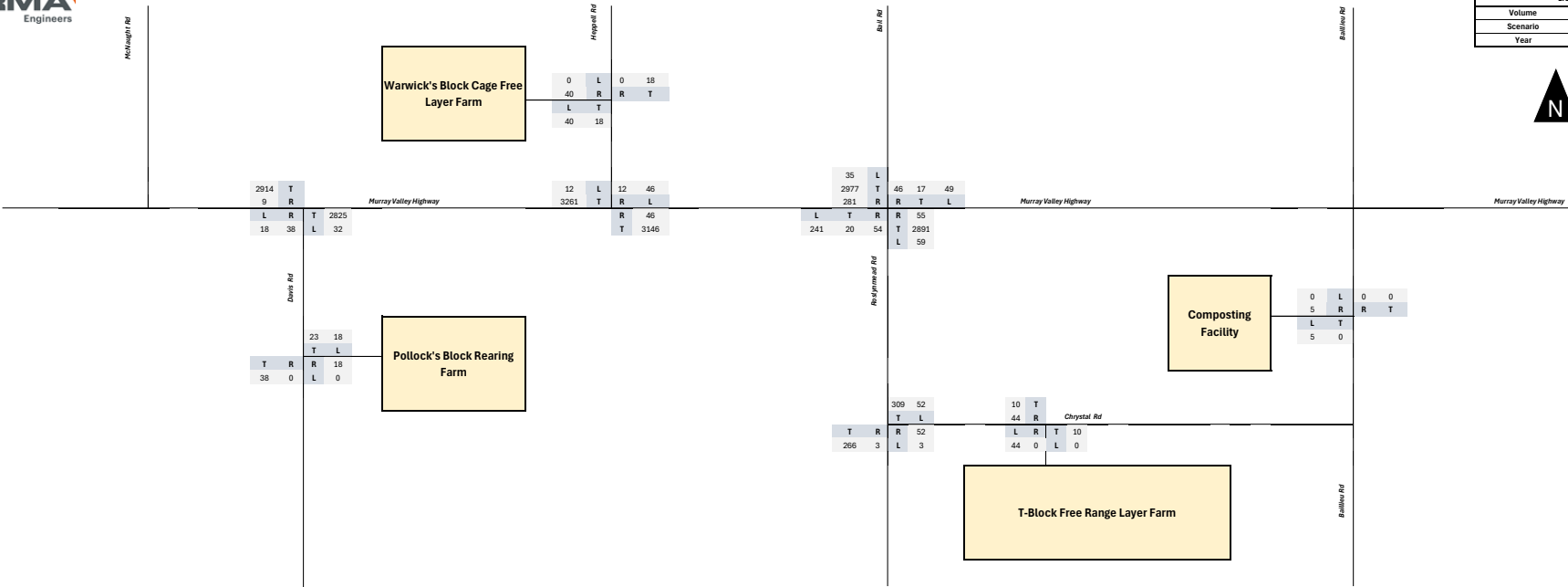

PEAK HOUR VOLUME SUMMARY HEAVY VEHICLES	
Volume	AM (PM)
Scenario	Background & Development (Network Peak)
Year	2052

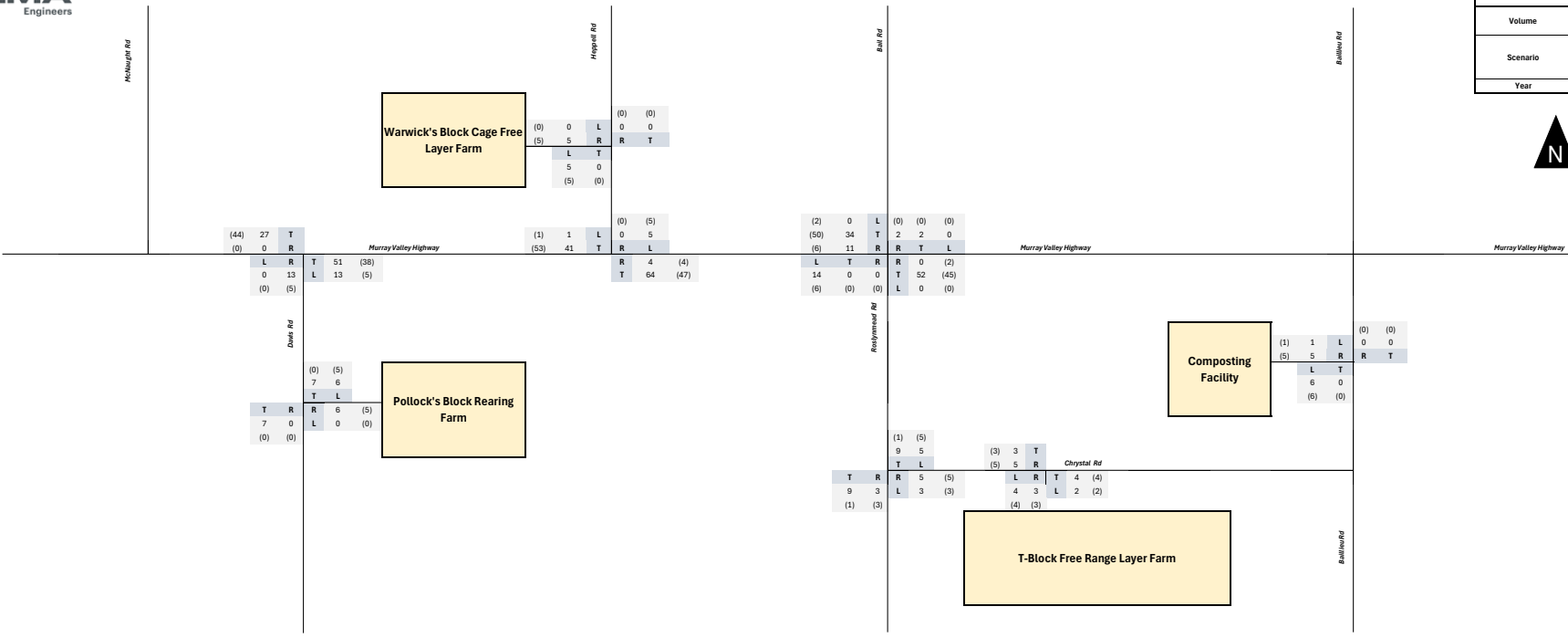

PEAK HOUR VOLUME SUMMARY HEAVY VEHICLES	
Volume	AM (PM)
Scenario	Background & Development (Development Peak 1)
Year	2052

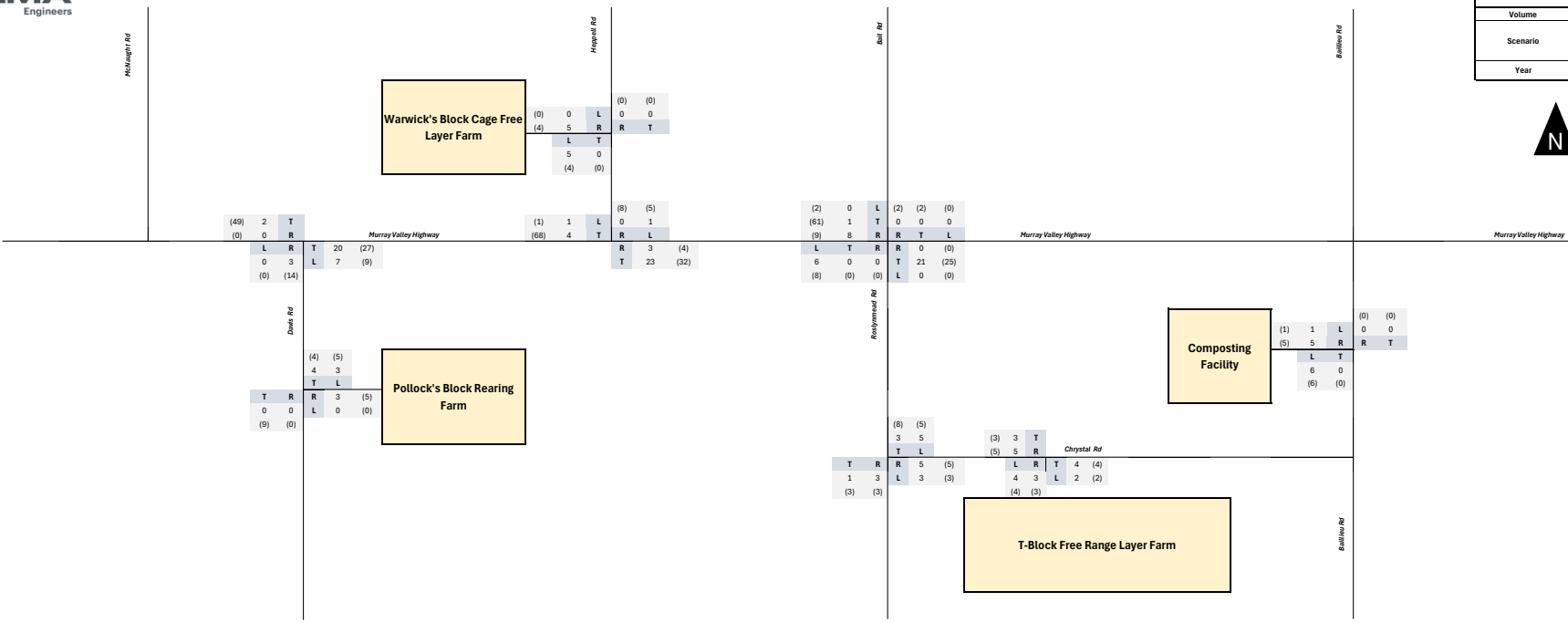

PEAK HOUR VOLUME SUMMARY HEAVY VEHICLES	
Volume	AM (PM)
Scenario	Background & Development (Development Peak 2)
Year	2052

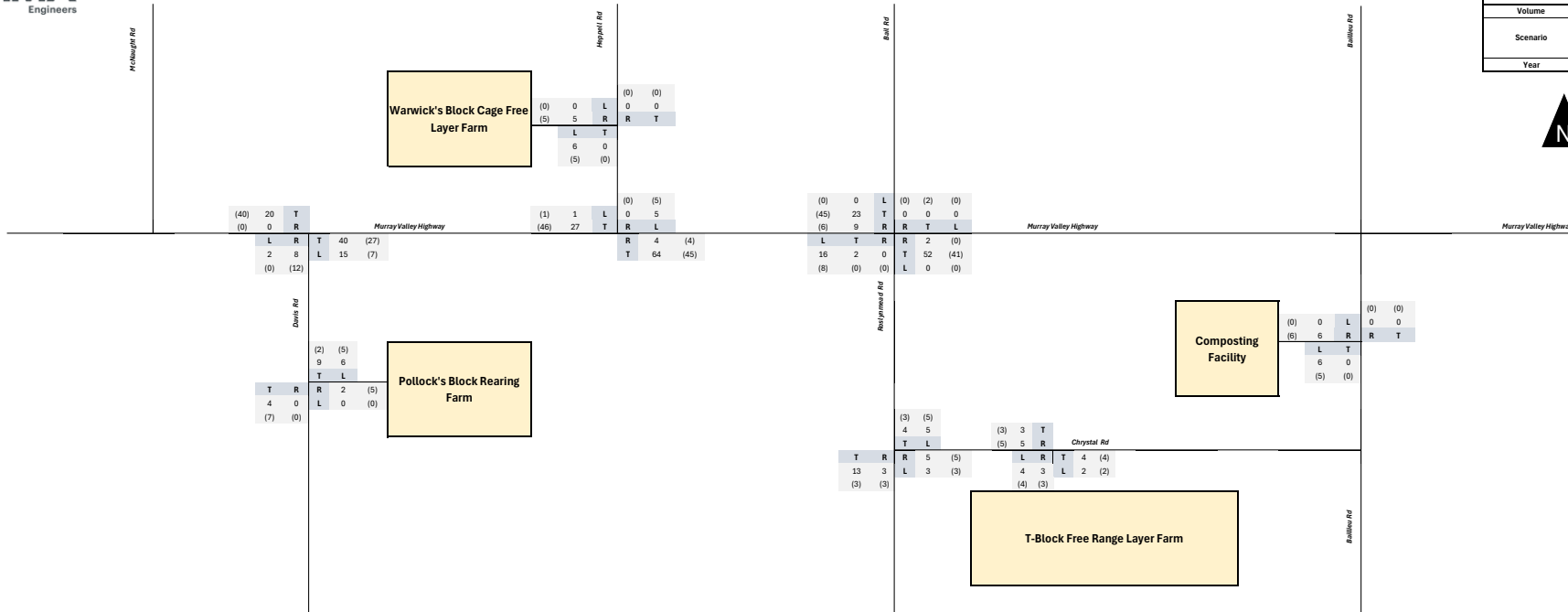

TRAFFIC VOLUME SUMMARY	
HEAVY VEHICLES	
Volume	Daily
Scenario	Background & Development
Year	2062

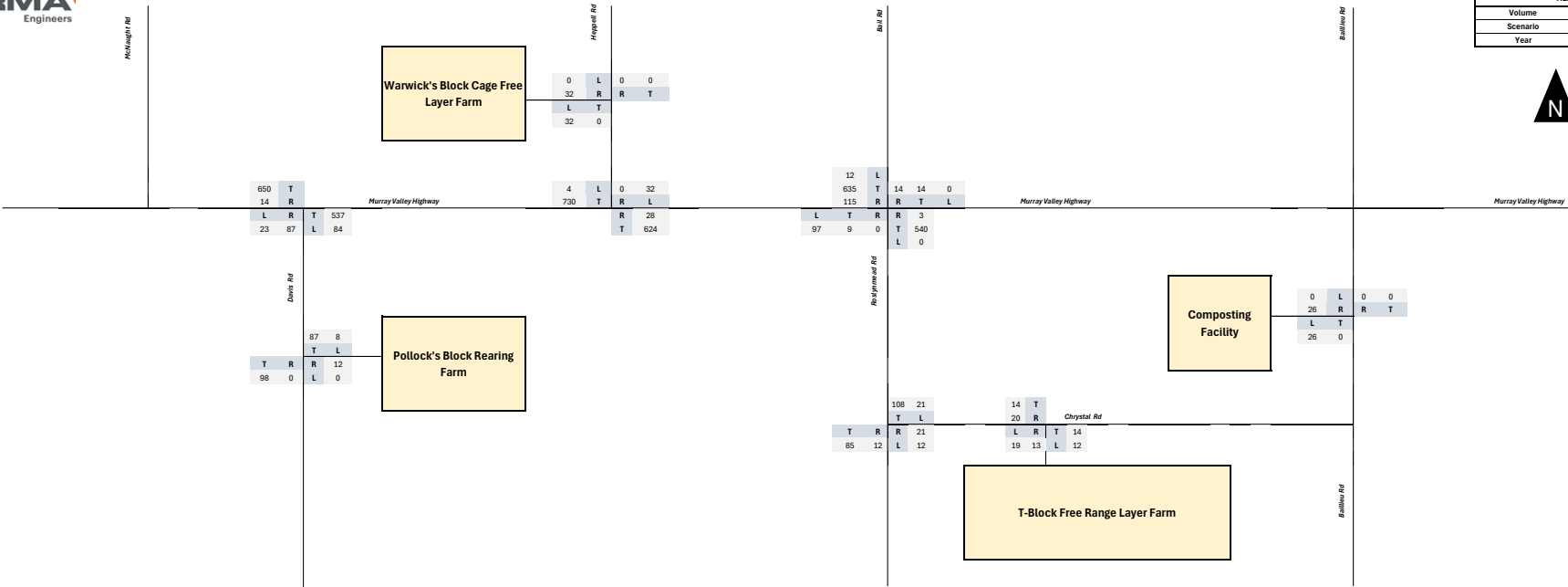

## Appendix F SIDRA analysis results

# SITE LAYOUT

▽ Site: [1] 2052 AM BG-DEV (Network Peak) (Murray Valley Highway / Davis Road Intersection)

Murray Valley Hwy/Davis Rd  
Site Category: (None)  
Give-Way (Two-Way)  
Site Scenario: 1 | Local Volumes

Layout pictures are schematic functional drawings reflecting input data. They are not design drawings.

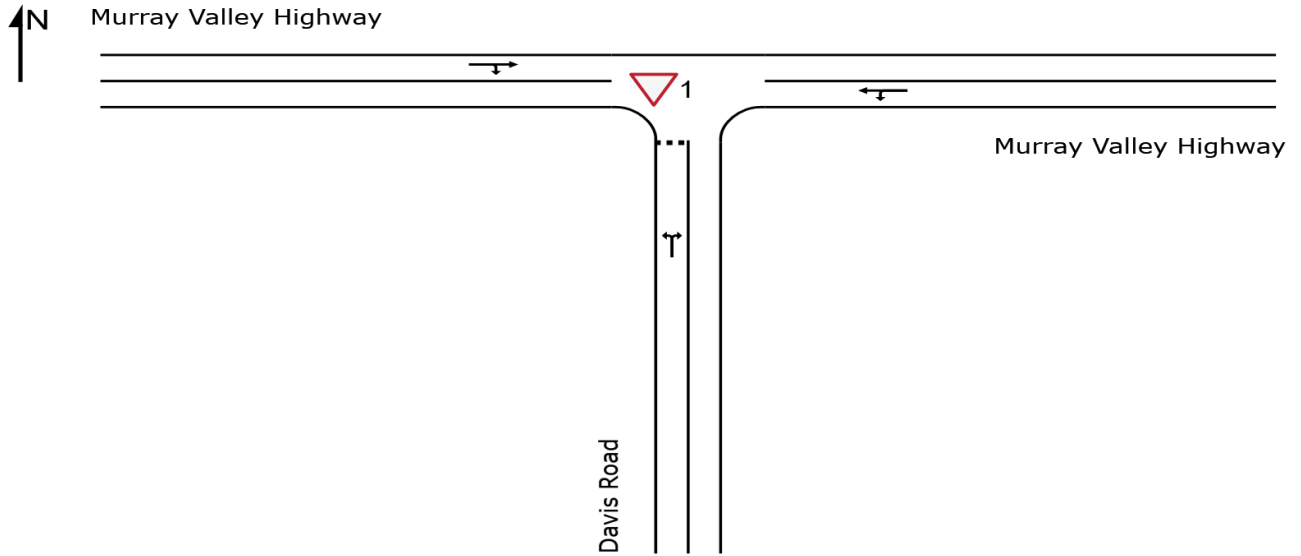

# MOVEMENT SUMMARY

Site: [1] 2052 AM BG-DEV (Network Peak) (Murray Valley Highway / Davis Road Intersection)

Output produced by SIDRA INTERSECTION Version: 10.0.5.217

Murray Valley Hwy/Davis Rd

Site Category: (None)

Give-Way (Two-Way)

Site Scenario: 1 | Local Volumes

Vehicle Movement Performance															
Mov ID	Turn	Mov Class	Demand Flows		Arrival Flows		Deg. Satn	Aver. Delay	Level of Service	95% Back Of Queue		Prop. Qued	Eff. Stop of Cycles Rate to Depart	Number of Cycles	Aver. Speed
			[ Total HV ]	[ Total HV ]	[ Veh. ]	[ Dist ]									
			veh/h	%	veh/h	%	v/c	sec		veh	m				km/h
South: Davis Road															
1	L2	All MCs	3	33.3	3	33.3	0.042	9.8	LOS A	0.1	1.6	0.54	0.79	0.54	57.5
3	R2	All MCs	15	92.9	15	92.9	0.042	16.6	LOS C	0.1	1.6	0.54	0.79	0.54	45.7
Approach			18	82.4	18	82.4	0.042	15.4	LOS C	0.1	1.6	0.54	0.79	0.54	47.4
East: Murray Valley Highway															
4	L2	All MCs	15	92.9	15	92.9	0.141	10.3	LOS B	0.0	0.0	0.00	0.04	0.00	56.0
5	T1	All MCs	215	25.0	215	25.0	0.141	0.0	LOS A	0.0	0.0	0.00	0.04	0.00	99.8
Approach			229	29.4	229	29.4	0.141	0.7	NA	0.0	0.0	0.00	0.04	0.00	95.0
West: Murray Valley Highway															
11	T1	All MCs	318	8.9	318	8.9	0.176	0.0	LOS A	0.0	0.3	0.01	0.01	0.01	99.7
12	R2	All MCs	3	33.3	3	33.3	0.176	8.8	LOS A	0.0	0.3	0.01	0.01	0.01	71.8
Approach			321	9.2	321	9.2	0.176	0.1	NA	0.0	0.3	0.01	0.01	0.01	99.3
All Vehicles			568	19.6	568	19.6	0.176	0.8	NA	0.1	1.6	0.02	0.05	0.02	94.3

Site Level of Service (LOS) Method: Delay (SIDRA). Site LOS Method is specified in the Parameter Settings dialog (Options tab).

Vehicle movement LOS values are based on average delay per movement.

Minor Road Approach LOS values are based on average delay for all vehicle movements.

NA (TWSC): Level of Service is not defined for major road approaches or the intersection as a whole for Two-Way Sign Control (HCM LOS rule).

Two-Way Sign Control Capacity Model: SIDRA Standard.

Delay Model: SIDRA Standard (Control Delay: Geometric Delay is included).

Queue Model: SIDRA queue estimation methods are used for Back of Queue and Queue at Start of Gap.

Gap-Acceptance Capacity Formula: SIDRA Standard (Akçelik M3D).

HV (%) values are calculated for All Movement Classes of All Heavy Vehicle Model Designation.

Arrival Flows used in performance calculations are adjusted to include any Initial Queued Demand and Upstream Capacity Constraint effects.

SIDRA INTERSECTION 10.0 | Copyright © 2000-2025 Akcelik and Associates Pty Ltd | sidrasolutions.com

Organisation: RMA ENGINEERS PTY LTD | Licence: NETWORK / 1PC | Processed: Monday, 21 July 2025 4:02:26 PM

Project: N:\Synergy\Projects\25E-0010 Poultry Farm - Torrumbarry\4 Design\Traffic\Sidra\Murray Valley Hwy - Davis Rd.sipx

# MOVEMENT SUMMARY

Site: [2] 2052 AM BG-DEV (Development Peak 1) (Murray Valley Highway / Davis Road Intersection)

Output produced by SIDRA INTERSECTION Version: 10.0.5.217

Murray Valley Hwy/Davis Rd

Site Category: (None)

Give-Way (Two-Way)

Site Scenario: 1 | Local Volumes

Vehicle Movement Performance													
Mov ID	Turn	Mov Class	Demand Flows	Arrival Flows	Deg. Satn	Aver. Delay	Level of Service	95% Back Of Queue		Prop. Qued	Eff. Stop Rate	Number of Cycles to Depart	Aver. Speed
			[ Total HV ]	[ Total HV ]	v/c	sec	[ Veh. Dist ]						km/h
			veh/h	%	veh/h	%			veh	m			
South: Davis Road													
1	L2	All MCs	2 50.0	2 50.0	0.007	9.3	LOS A	0.0	0.3	0.19	0.62	0.19	58.3
3	R2	All MCs	4 75.0	4 75.0	0.007	10.2	LOS B	0.0	0.3	0.19	0.62	0.19	52.0
Approach			6 66.7	6 66.7	0.007	9.9	LOS A	0.0	0.3	0.19	0.62	0.19	54.0
East: Murray Valley Highway													
4	L2	All MCs	9 77.8	9 77.8	0.035	9.9	LOS A	0.0	0.0	0.00	0.13	0.00	58.8
5	T1	All MCs	40 52.6	40 52.6	0.035	0.0	LOS A	0.0	0.0	0.00	0.13	0.00	97.9
Approach			49 57.4	49 57.4	0.035	1.9	NA	0.0	0.0	0.00	0.13	0.00	86.8
West: Murray Valley Highway													
11	T1	All MCs	64 33.3	64 33.3	0.036	0.0	LOS A	0.0	0.2	0.02	0.03	0.02	99.0
12	R2	All MCs	3 33.3	3 33.3	0.036	8.4	LOS A	0.0	0.2	0.02	0.03	0.02	71.5
Approach			67 4.7	67 4.7	0.036	0.4	NA	0.0	0.2	0.02	0.03	0.02	97.3
All Vehicles			123 29.1	123 29.1	0.036	1.5	NA	0.0	0.3	0.02	0.10	0.02	89.3

Site Level of Service (LOS) Method: Delay (SIDRA). Site LOS Method is specified in the Parameter Settings dialog (Options tab).

Vehicle movement LOS values are based on average delay per movement.

Minor Road Approach LOS values are based on average delay for all vehicle movements.

NA (TWSC): Level of Service is not defined for major road approaches or the intersection as a whole for Two-Way Sign Control (HCM LOS rule).

Two-Way Sign Control Capacity Model: SIDRA Standard.

Delay Model: SIDRA Standard (Control Delay: Geometric Delay is included).

Queue Model: SIDRA queue estimation methods are used for Back of Queue and Queue at Start of Gap.

Gap-Acceptance Capacity Formula: SIDRA Standard (Akçelik M3D).

HV (%) values are calculated for All Movement Classes of All Heavy Vehicle Model Designation.

Arrival Flows used in performance calculations are adjusted to include any Initial Queued Demand and Upstream Capacity Constraint effects.

SIDRA INTERSECTION 10.0 | Copyright © 2000-2025 Akcelik and Associates Pty Ltd | sidrasolutions.com

Organisation: RMA ENGINEERS PTY LTD | Licence: NETWORK / 1PC | Processed: Monday, 21 July 2025 4:02:26 PM

Project: N:\Synergy\Projects\25E-0010 Poultry Farm - Torrumbarry\4 Design\Traffic\Sidra\Murray Valley Hwy - Davis Rd.sipx

# MOVEMENT SUMMARY

Site: [3] 2052 AM BG-DEV (Development Peak 2) (Murray Valley Highway / Davis Road Intersection)

Output produced by SIDRA INTERSECTION Version: 10.0.5.217

Murray Valley Hwy/Davis Rd

Site Category: (None)

Give-Way (Two-Way)

Site Scenario: 1 | Local Volumes

Vehicle Movement Performance													
Mov ID	Turn	Mov Class	Demand Flows [ Total HV ]	Arrival Flows [ Total HV ]	Deg. Satn	Aver. Delay	Level of Service	95% Back Of Queue [ Veh. Dist ]		Prop. Qued	Eff. Stop of Cycles Rate to Depart	Number of Cycles	Aver. Speed
			veh/h	%	v/c	sec		veh	m				km/h
South: Davis Road													
1	L2	All MCs	3 66.7	3 66.7	0.020	10.4	LOS B	0.1	0.7	0.35	0.67	0.35	53.7
3	R2	All MCs	11 80.0	11 80.0	0.020	11.8	LOS B	0.1	0.7	0.35	0.67	0.35	50.3
Approach			14 76.9	14 76.9	0.020	11.5	LOS B	0.1	0.7	0.35	0.67	0.35	51.0
East: Murray Valley Highway													
4	L2	All MCs	31 51.7	31 51.7	0.101	9.2	LOS A	0.0	0.0	0.00	0.13	0.00	65.2
5	T1	All MCs	126 33.3	126 33.3	0.101	0.0	LOS A	0.0	0.0	0.00	0.13	0.00	96.8
Approach			157 36.9	157 36.9	0.101	1.8	NA	0.0	0.0	0.00	0.13	0.00	88.5
West: Murray Valley Highway													
11	T1	All MCs	108 19.4	108 19.4	0.068	0.1	LOS A	0.1	0.5	0.05	0.06	0.05	98.0
12	R2	All MCs	7 14.3	7 14.3	0.068	8.5	LOS A	0.1	0.5	0.05	0.06	0.05	78.7
Approach			116 19.1	116 19.1	0.068	0.6	NA	0.1	0.5	0.05	0.06	0.05	96.5
All Vehicles			286 31.6	286 31.6	0.101	1.8	NA	0.1	0.7	0.04	0.13	0.04	88.4

Site Level of Service (LOS) Method: Delay (SIDRA). Site LOS Method is specified in the Parameter Settings dialog (Options tab).

Vehicle movement LOS values are based on average delay per movement.

Minor Road Approach LOS values are based on average delay for all vehicle movements.

NA (TWSC): Level of Service is not defined for major road approaches or the intersection as a whole for Two-Way Sign Control (HCM LOS rule).

Two-Way Sign Control Capacity Model: SIDRA Standard.

Delay Model: SIDRA Standard (Control Delay: Geometric Delay is included).

Queue Model: SIDRA queue estimation methods are used for Back of Queue and Queue at Start of Gap.

Gap-Acceptance Capacity Formula: SIDRA Standard (Akçelik M3D).

HV (%) values are calculated for All Movement Classes of All Heavy Vehicle Model Designation.

Arrival Flows used in performance calculations are adjusted to include any Initial Queued Demand and Upstream Capacity Constraint effects.

SIDRA INTERSECTION 10.0 | Copyright © 2000-2025 Akcelik and Associates Pty Ltd | sidrasolutions.com

Organisation: RMA ENGINEERS PTY LTD | Licence: NETWORK / 1PC | Processed: Monday, 21 July 2025 4:02:27 PM

Project: N:\Synergy\Projects\25E-0010 Poultry Farm - Torrumbarry\4 Design\Traffic\Sidra\Murray Valley Hwy - Davis Rd.sipx

# MOVEMENT SUMMARY

Site: [4] 2052 PM BG-DEV (Network Peak) (Murray Valley Highway / Davis Road Intersection)

Output produced by SIDRA INTERSECTION Version: 10.0.5.217

Murray Valley Hwy/Davis Rd

Site Category: (None)

Give-Way (Two-Way)

Site Scenario: 1 | Local Volumes

Vehicle Movement Performance													
Mov ID	Turn	Mov Class	Demand Flows [ Total HV ]	Arrival Flows [ Total HV ]	Deg. Satn	Aver. Delay	Level of Service	95% Back Of Queue		Prop. Qued	Eff. Stop of Cycles	Number of Cycles	Aver. Speed
			veh/h	%	v/c	sec		veh	Dist m		Rate to Depart		km/h
South: Davis Road													
1	L2	All MCs	5 20.0	5 20.0	0.026	9.7	LOS A	0.1	0.8	0.50	0.73	0.50	62.6
3	R2	All MCs	9 55.6	9 55.6	0.026	14.3	LOS B	0.1	0.8	0.50	0.73	0.50	53.6
Approach			15 42.9	15 42.9	0.026	12.6	LOS B	0.1	0.8	0.50	0.73	0.50	56.5
East: Murray Valley Highway													
4	L2	All MCs	6 83.3	6 83.3	0.171	10.0	LOS B	0.0	0.0	0.00	0.01	0.00	58.1
5	T1	All MCs	297 13.5	297 13.5	0.171	0.0	LOS A	0.0	0.0	0.00	0.01	0.00	99.8
Approach			303 14.9	303 14.9	0.171	0.2	NA	0.0	0.0	0.00	0.01	0.00	98.4
West: Murray Valley Highway													
11	T1	All MCs	273 17.0	273 17.0	0.158	0.0	LOS A	0.0	0.2	0.01	0.01	0.01	99.7
12	R2	All MCs	2 50.0	2 50.0	0.158	9.5	LOS A	0.0	0.2	0.01	0.01	0.01	66.0
Approach			275 17.2	275 17.2	0.158	0.1	NA	0.0	0.2	0.01	0.01	0.01	99.4
All Vehicles			593 16.7	593 16.7	0.171	0.5	NA	0.1	0.8	0.02	0.03	0.02	97.0

Site Level of Service (LOS) Method: Delay (SIDRA). Site LOS Method is specified in the Parameter Settings dialog (Options tab).

Vehicle movement LOS values are based on average delay per movement.

Minor Road Approach LOS values are based on average delay for all vehicle movements.

NA (TWSC): Level of Service is not defined for major road approaches or the intersection as a whole for Two-Way Sign Control (HCM LOS rule).

Two-Way Sign Control Capacity Model: SIDRA Standard.

Delay Model: SIDRA Standard (Control Delay: Geometric Delay is included).

Queue Model: SIDRA queue estimation methods are used for Back of Queue and Queue at Start of Gap.

Gap-Acceptance Capacity Formula: SIDRA Standard (Akçelik M3D).

HV (%) values are calculated for All Movement Classes of All Heavy Vehicle Model Designation.

Arrival Flows used in performance calculations are adjusted to include any Initial Queued Demand and Upstream Capacity Constraint effects.

SIDRA INTERSECTION 10.0 | Copyright © 2000-2025 Akcelik and Associates Pty Ltd | sidrasolutions.com

Organisation: RMA ENGINEERS PTY LTD | Licence: NETWORK / 1PC | Processed: Monday, 21 July 2025 4:02:27 PM

Project: N:\Synergy\Projects\25E-0010 Poultry Farm - Torrumbarry\4 Design\Traffic\Sidra\Murray Valley Hwy - Davis Rd.sipx

# MOVEMENT SUMMARY

Site: [5] 2052 PM BG-DEV (Development Peak 1) (Murray Valley Highway / Davis Road Intersection)

Output produced by SIDRA INTERSECTION Version: 10.0.5.217

Murray Valley Hwy/Davis Rd

Site Category: (None)

Give-Way (Two-Way)

Site Scenario: 1 | Local Volumes

Vehicle Movement Performance													
Mov ID	Turn	Mov Class	Demand Flows [ Total HV ]	Arrival Flows [ Total HV ]	Deg. Satn	Aver. Delay	Level of Service	95% Back Of Queue		Prop. Qued	Eff. Stop of Cycles	Number of Cycles to Depart	Aver. Speed
			veh/h	%	v/c	sec		veh	Dist m				km/h
South: Davis Road													
1	L2	All MCs	250.0	250.0	0.043	10.6	LOS B	0.1	1.7	0.54	0.81	0.54	53.9
3	R2	All MCs	1693.3	1693.3	0.043	16.3	LOS C	0.1	1.7	0.54	0.81	0.54	45.6
Approach			1888.2	1888.2	0.043	15.7	LOS C	0.1	1.7	0.54	0.81	0.54	46.4
East: Murray Valley Highway													
4	L2	All MCs	1190.0	1190.0	0.150	10.2	LOS B	0.0	0.0	0.00	0.03	0.00	56.6
5	T1	All MCs	25711.1	25711.1	0.150	0.0	LOS A	0.0	0.0	0.00	0.03	0.00	99.8
Approach			26714.2	26714.2	0.150	0.4	NA	0.0	0.0	0.00	0.03	0.00	96.9
West: Murray Valley Highway													
11	T1	All MCs	26919.1	26919.1	0.158	0.0	LOS A	0.0	0.2	0.01	0.01	0.01	99.8
12	R2	All MCs	250.0	250.0	0.158	9.3	LOS A	0.0	0.2	0.01	0.01	0.01	66.1
Approach			27219.4	27219.4	0.158	0.1	NA	0.0	0.2	0.01	0.01	0.01	99.4
All Vehicles			55719.1	55719.1	0.158	0.7	NA	0.1	1.7	0.02	0.04	0.02	94.7

Site Level of Service (LOS) Method: Delay (SIDRA). Site LOS Method is specified in the Parameter Settings dialog (Options tab).

Vehicle movement LOS values are based on average delay per movement.

Minor Road Approach LOS values are based on average delay for all vehicle movements.

NA (TWSC): Level of Service is not defined for major road approaches or the intersection as a whole for Two-Way Sign Control (HCM LOS rule).

Two-Way Sign Control Capacity Model: SIDRA Standard.

Delay Model: SIDRA Standard (Control Delay: Geometric Delay is included).

Queue Model: SIDRA queue estimation methods are used for Back of Queue and Queue at Start of Gap.

Gap-Acceptance Capacity Formula: SIDRA Standard (Akçelik M3D).

HV (%) values are calculated for All Movement Classes of All Heavy Vehicle Model Designation.

Arrival Flows used in performance calculations are adjusted to include any Initial Queued Demand and Upstream Capacity Constraint effects.

SIDRA INTERSECTION 10.0 | Copyright © 2000-2025 Akcelik and Associates Pty Ltd | sidrasolutions.com

Organisation: RMA ENGINEERS PTY LTD | Licence: NETWORK / 1PC | Processed: Monday, 21 July 2025 4:02:28 PM

Project: N:\Synergy\Projects\25E-0010 Poultry Farm - Torrumbarry\4 Design\Traffic\Sidra\Murray Valley Hwy - Davis Rd.sipx

# MOVEMENT SUMMARY

Site: [6] 2052 PM BG-DEV (Development Peak 2) (Murray Valley Highway / Davis Road Intersection)

Output produced by SIDRA INTERSECTION Version: 10.0.5.217

Murray Valley Hwy/Davis Rd

Site Category: (None)

Give-Way (Two-Way)

Site Scenario: 1 | Local Volumes

Vehicle Movement Performance													
Mov ID	Turn	Mov Class	Demand Flows [ Total HV ]	Arrival Flows [ Total HV ]	Deg. Satn	Aver. Delay	Level of Service	95% Back Of Queue [ Veh. ]	Dist [ m ]	Prop. Qued	Eff. Stop of Cycles Rate to Depart	Number of Cycles	Aver. Speed
			veh/h	%	veh/h	%	v/c	sec					km/h
South: Davis Road													
1	L2	All MCs	5 20.0	5 20.0	0.068	9.7	LOS A	0.2	1.9	0.49	0.78	0.49	63.0
3	R2	All MCs	35 36.4	35 36.4	0.068	12.4	LOS B	0.2	1.9	0.49	0.78	0.49	58.2
Approach			40 34.2	40 34.2	0.068	12.1	LOS B	0.2	1.9	0.49	0.78	0.49	58.8
East: Murray Valley Highway													
4	L2	All MCs	8 87.5	8 87.5	0.166	10.1	LOS B	0.0	0.0	0.00	0.02	0.00	57.2
5	T1	All MCs	292 9.7	292 9.7	0.166	0.0	LOS A	0.0	0.0	0.00	0.02	0.00	99.8
Approach			300 11.9	300 11.9	0.166	0.3	NA	0.0	0.0	0.00	0.02	0.00	97.8
West: Murray Valley Highway													
11	T1	All MCs	229 18.3	229 18.3	0.134	0.0	LOS A	0.0	0.2	0.01	0.01	0.01	99.7
12	R2	All MCs	2 50.0	2 50.0	0.134	9.6	LOS A	0.0	0.2	0.01	0.01	0.01	66.0
Approach			232 18.6	232 18.6	0.134	0.1	NA	0.0	0.2	0.01	0.01	0.01	99.2
All Vehicles			572 16.2	572 16.2	0.166	1.0	NA	0.2	1.9	0.04	0.07	0.04	94.0

Site Level of Service (LOS) Method: Delay (SIDRA). Site LOS Method is specified in the Parameter Settings dialog (Options tab).

Vehicle movement LOS values are based on average delay per movement.

Minor Road Approach LOS values are based on average delay for all vehicle movements.

NA (TWSC): Level of Service is not defined for major road approaches or the intersection as a whole for Two-Way Sign Control (HCM LOS rule).

Two-Way Sign Control Capacity Model: SIDRA Standard.

Delay Model: SIDRA Standard (Control Delay: Geometric Delay is included).

Queue Model: SIDRA queue estimation methods are used for Back of Queue and Queue at Start of Gap.

Gap-Acceptance Capacity Formula: SIDRA Standard (Akçelik M3D).

HV (%) values are calculated for All Movement Classes of All Heavy Vehicle Model Designation.

Arrival Flows used in performance calculations are adjusted to include any Initial Queued Demand and Upstream Capacity Constraint effects.

SIDRA INTERSECTION 10.0 | Copyright © 2000-2025 Akcelik and Associates Pty Ltd | sidrasolutions.com

Organisation: RMA ENGINEERS PTY LTD | Licence: NETWORK / 1PC | Processed: Monday, 21 July 2025 4:02:28 PM

Project: N:\Synergy\Projects\25E-0010 Poultry Farm - Torrumbarry\4 Design\Traffic\Sidra\Murray Valley Hwy - Davis Rd.sipx

# SIGN CONTROL ANALYSIS

Site: [1] 2052 AM BG-DEV (Network Peak) (Murray Valley Highway / Davis Road Intersection)

Output produced by SIDRA INTERSECTION Version: 10.0.5.217

Murray Valley Hwy/Davis Rd

Site Category: (None)

Give-Way (Two-Way)

Site Scenario: 1 | Local Volumes

Sign Control Basic Parameters				
Approach Control	Leg Geometry	App. Dist m	Prop Queued Upstr Signal	Extra Bunching %
South: Davis Road				
Give-Way	Two Way	500.0	NA <sup>5</sup>	0.0 <sup>3</sup>
East: Murray Valley Highway				
Major Road	Two Way	500.0	NA <sup>5</sup>	0.0 <sup>3</sup>
West: Murray Valley Highway				
Major Road	Two Way	500.0	NA <sup>5</sup>	0.0 <sup>3</sup>

Two-Way Sign Control Capacity Model: SIDRA Standard.

Gap-Acceptance Capacity Formula: SIDRA Standard (Akçelik M3D).

<sup>3</sup> User-specified Extra Bunching

<sup>5</sup> Not Applicable (single Site analysis or unconnected Site in Network analysis).

Gap Acceptance Parameters												
Opposed Lane	Dest	Turn	Apply Calib	Opng Flow veh/h	Opng Flow pcu/h	In-Bunch Hdwy sec	Prop. Bunched	Gap Acc Factor	Critical Gap [ Hdwy Dist ] sec	Follow-up Hdwy (tf) m	Ratio tf / tc sec	
South: Davis Road												
1	East	R2	Y	543 <sup>14</sup>	588 <sup>14</sup>	1.00	0.037	1.46	6.30	174.0	4.10	0.65
1	West	L2	Y	215	242	1.80	0.027	1.17	4.67	129.6	2.57	0.55
East: Murray Valley Highway												
No opposed movements on this approach.												
West: Murray Valley Highway												
1	South	R2	Y	229 <sup>14</sup>	263 <sup>14</sup>	1.80	0.029	1.17	4.67	123.0	2.33	0.50

Two-Way Sign Control Capacity Model: SIDRA Standard.

Gap-Acceptance Capacity Formula: SIDRA Standard (Akçelik M3D).

Values in this table are adjusted for movement classes in the entry stream.

Use the Pedestrians and Priorities input dialogs to specify opposing pedestrian movements.

<sup>14</sup> Percentage of exiting flow included in opposing vehicle flow

Gap Acceptance Cycle Parameters (Lanes)					
Opposed Lane	Cycle Time sec	Blocked Time sec	Unblocked Time sec	Unblocked Time Ratio	Minimum Delay sec
South: Davis Road					
1	17.51	8.84	8.67	0.495	4.9
East: Murray Valley Highway					
No opposed movements on this approach.					
West: Murray Valley Highway					

1	17.81	4.41	13.41	0.753	0.0
---	-------	------	-------	-------	-----

Two-Way Sign Control Capacity Model: SIDRA Standard.  
 Gap-Acceptance Capacity Formula: SIDRA Standard (Akçelik M3D).

Gap Acceptance Cycle Parameters (Movements)								
To Approach	Turn	Lane No	Cycle Time sec	Blocked Time sec	Unblocked Time sec	Unblocked Time Ratio	Minimum Delay sec	
South: Davis Road								
West	L2	1	18.95	4.20	14.75	0.778	0.9	
East	R2	1	17.21	9.84	7.37	0.428	5.7	
East: Murray Valley Highway								
No opposed movements on this approach.								
West: Murray Valley Highway								
South	R2	1	17.81	4.41	13.41	0.753	1.0	

Two-Way Sign Control Capacity Model: SIDRA Standard.  
 Gap-Acceptance Capacity Formula: SIDRA Standard (Akçelik M3D).

# SIGN CONTROL ANALYSIS

Site: [2] 2052 AM BG-DEV (Development Peak 1) (Murray Valley Highway / Davis Road Intersection)

Output produced by SIDRA INTERSECTION Version: 10.0.5.217

Murray Valley Hwy/Davis Rd

Site Category: (None)

Give-Way (Two-Way)

Site Scenario: 1 | Local Volumes

Sign Control Basic Parameters				
Approach Control	Leg Geometry	App. Dist m	Prop Queued Upstr Signal	Extra Bunching %
South: Davis Road				
Give-Way	Two Way	500.0	NA <sup>5</sup>	0.0 <sup>3</sup>
East: Murray Valley Highway				
Major Road	Two Way	500.0	NA <sup>5</sup>	0.0 <sup>3</sup>
West: Murray Valley Highway				
Major Road	Two Way	500.0	NA <sup>5</sup>	0.0 <sup>3</sup>

Two-Way Sign Control Capacity Model: SIDRA Standard.

Gap-Acceptance Capacity Formula: SIDRA Standard (Akçelik M3D).

<sup>3</sup> User-specified Extra Bunching

<sup>5</sup> Not Applicable (single Site analysis or unconnected Site in Network analysis).

Gap Acceptance Parameters												
Opposed Lane	Dest	Turn	Apply Calib	Opng Flow veh/h	Opng Flow pcu/h	In-Bunch Hdwy sec	Prop. Bunched	Gap Acc Factor	Critical Gap [Hdwy Dist] sec	Follow-up Hdwy (tf) m	Ratio tf / tc	
South: Davis Road												
1	East	R2	Y	112 <sup>14</sup>	126 <sup>14</sup>	0.97	0.007	1.38	5.91	160.2	3.85	0.65
1	West	L2	Y	40	51	1.80	0.005	1.25	5.00	138.9	2.75	0.55
East: Murray Valley Highway												
No opposed movements on this approach.												
West: Murray Valley Highway												
1	South	R2	Y	49 <sup>14</sup>	64 <sup>14</sup>	1.80	0.007	1.17	4.67	109.8	2.33	0.50

Two-Way Sign Control Capacity Model: SIDRA Standard.

Gap-Acceptance Capacity Formula: SIDRA Standard (Akçelik M3D).

Values in this table are adjusted for movement classes in the entry stream.

Use the Pedestrians and Priorities input dialogs to specify opposing pedestrian movements.

<sup>14</sup> Percentage of exiting flow included in opposing vehicle flow

Gap Acceptance Cycle Parameters (Lanes)					
Opposed Lane	Cycle Time sec	Blocked Time sec	Unblocked Time sec	Unblocked Time Ratio	Minimum Delay sec
South: Davis Road					
1	47.90	4.37	43.54	0.909	0.5
East: Murray Valley Highway					
No opposed movements on this approach.					
West: Murray Valley Highway					

1	59.94	3.68	56.26	0.939	0.0
---	-------	------	-------	-------	-----

Two-Way Sign Control Capacity Model: SIDRA Standard.  
 Gap-Acceptance Capacity Formula: SIDRA Standard (Akçelik M3D).

Gap Acceptance Cycle Parameters (Movements)								
To Approach	Turn	Lane No	Cycle Time sec	Blocked Time sec	Unblocked Time sec	Unblocked Time Ratio	Minimum Delay sec	
South: Davis Road								
West	L2	1	74.98	3.79	71.18	0.949	0.2	
East	R2	1	34.36	4.65	29.71	0.865	0.7	
East: Murray Valley Highway								
No opposed movements on this approach.								
West: Murray Valley Highway								
South	R2	1	59.94	3.68	56.26	0.939	0.2	

Two-Way Sign Control Capacity Model: SIDRA Standard.  
 Gap-Acceptance Capacity Formula: SIDRA Standard (Akçelik M3D).

# SIGN CONTROL ANALYSIS

Site: [3] 2052 AM BG-DEV (Development Peak 2) (Murray Valley Highway / Davis Road Intersection)

Output produced by SIDRA INTERSECTION Version: 10.0.5.217

Murray Valley Hwy/Davis Rd

Site Category: (None)

Give-Way (Two-Way)

Site Scenario: 1 | Local Volumes

Sign Control Basic Parameters				
Approach Control	Leg Geometry	App. Dist m	Prop Queued Upstr Signal	Extra Bunching %
South: Davis Road				
Give-Way	Two Way	500.0	NA <sup>5</sup>	0.0 <sup>3</sup>
East: Murray Valley Highway				
Major Road	Two Way	500.0	NA <sup>5</sup>	0.0 <sup>3</sup>
West: Murray Valley Highway				
Major Road	Two Way	500.0	NA <sup>5</sup>	0.0 <sup>3</sup>

Two-Way Sign Control Capacity Model: SIDRA Standard.

Gap-Acceptance Capacity Formula: SIDRA Standard (Akçelik M3D).

<sup>3</sup> User-specified Extra Bunching

<sup>5</sup> Not Applicable (single Site analysis or unconnected Site in Network analysis).

Gap Acceptance Parameters												
Opposed Lane	Dest	Turn	Apply Calib	Opng Flow veh/h	Opng Flow pcu/h	In-Bunch Hdwy sec	Prop. Bunched	Gap Acc Factor	Critical Gap [Hdwy Dist] sec	Follow-up Hdwy (tf) m	Ratio tf / tc	
South: Davis Road												
1	East	R2	Y	257 <sup>14</sup>	293 <sup>14</sup>	0.99	0.017	1.40	6.02	163.0	3.92	0.65
1	West	L2	Y	126	147	1.80	0.016	1.33	5.33	148.1	2.93	0.55
East: Murray Valley Highway												
No opposed movements on this approach.												
West: Murray Valley Highway												
1	South	R2	Y	157 <sup>14</sup>	186 <sup>14</sup>	1.80	0.020	1.07	4.29	100.6	2.14	0.50

Two-Way Sign Control Capacity Model: SIDRA Standard.

Gap-Acceptance Capacity Formula: SIDRA Standard (Akçelik M3D).

Values in this table are adjusted for movement classes in the entry stream.

Use the Pedestrians and Priorities input dialogs to specify opposing pedestrian movements.

<sup>14</sup> Percentage of exiting flow included in opposing vehicle flow

Gap Acceptance Cycle Parameters (Lanes)					
Opposed Lane	Cycle Time sec	Blocked Time sec	Unblocked Time sec	Unblocked Time Ratio	Minimum Delay sec
South: Davis Road					
1	21.56	5.58	15.98	0.741	1.6
East: Murray Valley Highway					
No opposed movements on this approach.					
West: Murray Valley Highway					

1	22.71	3.70	19.01	0.837	0.1
---	-------	------	-------	-------	-----

Two-Way Sign Control Capacity Model: SIDRA Standard.  
 Gap-Acceptance Capacity Formula: SIDRA Standard (Akçelik M3D).

Gap Acceptance Cycle Parameters (Movements)								
To Approach	Turn	Lane No	Cycle Time sec	Blocked Time sec	Unblocked Time sec	Unblocked Time Ratio	Minimum Delay sec	
South: Davis Road								
West	L2	1	28.94	4.49	24.46	0.845	0.7	
East	R2	1	19.35	5.91	13.43	0.694	1.9	
East: Murray Valley Highway								
No opposed movements on this approach.								
West: Murray Valley Highway								
South	R2	1	22.71	3.70	19.01	0.837	0.6	

Two-Way Sign Control Capacity Model: SIDRA Standard.  
 Gap-Acceptance Capacity Formula: SIDRA Standard (Akçelik M3D).

# SIGN CONTROL ANALYSIS

Site: [4] 2052 PM BG-DEV (Network Peak) (Murray Valley Highway / Davis Road Intersection)

Output produced by SIDRA INTERSECTION Version: 10.0.5.217

Murray Valley Hwy/Davis Rd

Site Category: (None)

Give-Way (Two-Way)

Site Scenario: 1 | Local Volumes

Sign Control Basic Parameters				
Approach Control	Leg Geometry	App. Dist m	Prop Queued Upstr Signal	Extra Bunching %
South: Davis Road				
Give-Way	Two Way	500.0	NA <sup>5</sup>	0.0 <sup>3</sup>
East: Murray Valley Highway				
Major Road	Two Way	500.0	NA <sup>5</sup>	0.0 <sup>3</sup>
West: Murray Valley Highway				
Major Road	Two Way	500.0	NA <sup>5</sup>	0.0 <sup>3</sup>

Two-Way Sign Control Capacity Model: SIDRA Standard.

Gap-Acceptance Capacity Formula: SIDRA Standard (Akçelik M3D).

<sup>3</sup> User-specified Extra Bunching

<sup>5</sup> Not Applicable (single Site analysis or unconnected Site in Network analysis).

Gap Acceptance Parameters												
Opposed Lane	Dest	Turn	Apply Calib	Opng Flow veh/h	Opng Flow pcu/h	In-Bunch Hdwy sec	Prop. Bunched	Gap Acc Factor	Critical Gap [Hdwy Dist] sec	Follow-up Hdwy (tf) m	Ratio tf / tc	
South: Davis Road												
1	East	R2	Y	575 <sup>14</sup>	620 <sup>14</sup>	0.93	0.037	1.28	5.49	152.2	3.58	0.65
1	West	L2	Y	297	317	1.80	0.036	1.10	4.40	122.2	2.42	0.55
East: Murray Valley Highway												
No opposed movements on this approach.												
West: Murray Valley Highway												
1	South	R2	Y	303 <sup>14</sup>	326 <sup>14</sup>	1.80	0.037	1.25	5.00	136.6	2.50	0.50

Two-Way Sign Control Capacity Model: SIDRA Standard.

Gap-Acceptance Capacity Formula: SIDRA Standard (Akçelik M3D).

Values in this table are adjusted for movement classes in the entry stream.

Use the Pedestrians and Priorities input dialogs to specify opposing pedestrian movements.

<sup>14</sup> Percentage of exiting flow included in opposing vehicle flow

Gap Acceptance Cycle Parameters (Lanes)					
Opposed Lane	Cycle Time sec	Blocked Time sec	Unblocked Time sec	Unblocked Time Ratio	Minimum Delay sec
South: Davis Road					
1	15.02	6.64	8.38	0.558	3.4
East: Murray Valley Highway					
No opposed movements on this approach.					
West: Murray Valley Highway					

1	16.02	5.16	10.86	0.678	0.0
---	-------	------	-------	-------	-----

Two-Way Sign Control Capacity Model: SIDRA Standard.  
 Gap-Acceptance Capacity Formula: SIDRA Standard (Akçelik M3D).

Gap Acceptance Cycle Parameters (Movements)								
To Approach	Turn	Lane No	Cycle Time sec	Blocked Time sec	Unblocked Time sec	Unblocked Time Ratio	Minimum Delay sec	
South: Davis Road								
West	L2	1	15.32	4.19	11.13	0.727	1.1	
East	R2	1	14.85	7.99	6.86	0.462	4.7	
East: Murray Valley Highway								
No opposed movements on this approach.								
West: Murray Valley Highway								
South	R2	1	16.02	5.16	10.86	0.678	1.6	

Two-Way Sign Control Capacity Model: SIDRA Standard.  
 Gap-Acceptance Capacity Formula: SIDRA Standard (Akçelik M3D).

# SIGN CONTROL ANALYSIS

Site: [5] 2052 PM BG-DEV (Development Peak 1) (Murray Valley Highway / Davis Road Intersection)

Output produced by SIDRA INTERSECTION Version: 10.0.5.217

Murray Valley Hwy/Davis Rd

Site Category: (None)

Give-Way (Two-Way)

Site Scenario: 1 | Local Volumes

Sign Control Basic Parameters				
Approach Control	Leg Geometry	App. Dist m	Prop Queued Upstr Signal	Extra Bunching %
South: Davis Road				
Give-Way	Two Way	500.0	NA <sup>5</sup>	0.0 <sup>3</sup>
East: Murray Valley Highway				
Major Road	Two Way	500.0	NA <sup>5</sup>	0.0 <sup>3</sup>
West: Murray Valley Highway				
Major Road	Two Way	500.0	NA <sup>5</sup>	0.0 <sup>3</sup>

Two-Way Sign Control Capacity Model: SIDRA Standard.

Gap-Acceptance Capacity Formula: SIDRA Standard (Akçelik M3D).

<sup>3</sup> User-specified Extra Bunching

<sup>5</sup> Not Applicable (single Site analysis or unconnected Site in Network analysis).

Gap Acceptance Parameters												
Opposed Lane	Dest	Turn	Apply Calib	Opng Flow veh/h	Opng Flow pcu/h	In-Bunch Hdwy sec	Prop. Bunched	Gap Acc Factor	Critical Gap [ Hdwy Dist ] sec	Follow-up Hdwy (tf) m	Ratio tf / tc	
South: Davis Road												
1	East	R2	Y	534 <sup>14</sup>	577 <sup>14</sup>	0.92	0.034	1.47	6.31	174.6	4.11	0.65
1	West	L2	Y	257	271	1.80	0.030	1.25	5.00	138.9	2.75	0.55
East: Murray Valley Highway												
No opposed movements on this approach.												
West: Murray Valley Highway												
1	South	R2	Y	267 <sup>14</sup>	286 <sup>14</sup>	1.80	0.032	1.25	5.00	134.5	2.50	0.50

Two-Way Sign Control Capacity Model: SIDRA Standard.

Gap-Acceptance Capacity Formula: SIDRA Standard (Akçelik M3D).

Values in this table are adjusted for movement classes in the entry stream.

Use the Pedestrians and Priorities input dialogs to specify opposing pedestrian movements.

<sup>14</sup> Percentage of exiting flow included in opposing vehicle flow

Gap Acceptance Cycle Parameters (Lanes)					
Opposed Lane	Cycle Time sec	Blocked Time sec	Unblocked Time sec	Unblocked Time Ratio	Minimum Delay sec
South: Davis Road					
1	17.27	9.04	8.22	0.476	5.0
East: Murray Valley Highway					
No opposed movements on this approach.					
West: Murray Valley Highway					

1	17.32	4.94	12.38	0.715	0.0
---	-------	------	-------	-------	-----

Two-Way Sign Control Capacity Model: SIDRA Standard.  
 Gap-Acceptance Capacity Formula: SIDRA Standard (Akçelik M3D).

Gap Acceptance Cycle Parameters (Movements)								
To Approach	Turn	Lane No	Cycle Time sec	Blocked Time sec	Unblocked Time sec	Unblocked Time Ratio	Minimum Delay sec	
South: Davis Road								
West	L2	1	17.95	4.73	13.22	0.736	1.2	
East	R2	1	17.18	9.62	7.56	0.440	5.5	
East: Murray Valley Highway								
No opposed movements on this approach.								
West: Murray Valley Highway								
South	R2	1	17.32	4.94	12.38	0.715	1.3	

Two-Way Sign Control Capacity Model: SIDRA Standard.  
 Gap-Acceptance Capacity Formula: SIDRA Standard (Akçelik M3D).

# SIGN CONTROL ANALYSIS

Site: [6] 2052 PM BG-DEV (Development Peak 2) (Murray Valley Highway / Davis Road Intersection)

Output produced by SIDRA INTERSECTION Version: 10.0.5.217

Murray Valley Hwy/Davis Rd

Site Category: (None)

Give-Way (Two-Way)

Site Scenario: 1 | Local Volumes

Sign Control Basic Parameters				
Approach Control	Leg Geometry	App. Dist m	Prop Queued Upstr Signal	Extra Bunching %
South: Davis Road				
Give-Way	Two Way	500.0	NA <sup>5</sup>	0.0 <sup>3</sup>
East: Murray Valley Highway				
Major Road	Two Way	500.0	NA <sup>5</sup>	0.0 <sup>3</sup>
West: Murray Valley Highway				
Major Road	Two Way	500.0	NA <sup>5</sup>	0.0 <sup>3</sup>

Two-Way Sign Control Capacity Model: SIDRA Standard.

Gap-Acceptance Capacity Formula: SIDRA Standard (Akçelik M3D).

<sup>3</sup> User-specified Extra Bunching

<sup>5</sup> Not Applicable (single Site analysis or unconnected Site in Network analysis).

Gap Acceptance Parameters												
Opposed Lane	Dest	Turn	Apply Calib	Opng Flow veh/h	Opng Flow pcu/h	In-Bunch Hdw sec	Prop. Bunched	Gap Acc Factor	Critical Gap [Hdw sec]	Gap (tc) Dist m	Follow-up Hdw (tf) sec	Ratio tf / tc
South: Davis Road												
1	East	R2	Y	527 <sup>14</sup>	565 <sup>14</sup>	0.97	0.035	1.18	5.08	140.7	3.31	0.65
1	West	L2	Y	292	306	1.80	0.035	1.10	4.40	122.2	2.42	0.55
East: Murray Valley Highway												
No opposed movements on this approach.												
West: Murray Valley Highway												
1	South	R2	Y	300 <sup>14</sup>	318 <sup>14</sup>	1.80	0.036	1.25	5.00	135.8	2.50	0.50

Two-Way Sign Control Capacity Model: SIDRA Standard.

Gap-Acceptance Capacity Formula: SIDRA Standard (Akçelik M3D).

Values in this table are adjusted for movement classes in the entry stream.

Use the Pedestrians and Priorities input dialogs to specify opposing pedestrian movements.

<sup>14</sup> Percentage of exiting flow included in opposing vehicle flow

Gap Acceptance Cycle Parameters (Lanes)					
Opposed Lane	Cycle Time sec	Blocked Time sec	Unblocked Time sec	Unblocked Time Ratio	Minimum Delay sec
South: Davis Road					
1	14.02	6.20	7.81	0.558	3.1
East: Murray Valley Highway					
No opposed movements on this approach.					
West: Murray Valley Highway					

1	16.25	5.11	11.13	0.685	0.0
---	-------	------	-------	-------	-----

Two-Way Sign Control Capacity Model: SIDRA Standard.  
 Gap-Acceptance Capacity Formula: SIDRA Standard (Akçelik M3D).

Gap Acceptance Cycle Parameters (Movements)								
To Approach	Turn	Lane No	Cycle Time sec	Blocked Time sec	Unblocked Time sec	Unblocked Time Ratio	Minimum Delay sec	
South: Davis Road								
West	L2	1	15.69	4.14	11.54	0.736	1.1	
East	R2	1	13.76	6.51	7.25	0.527	3.4	
East: Murray Valley Highway								
No opposed movements on this approach.								
West: Murray Valley Highway								
South	R2	1	16.25	5.11	11.13	0.685	1.5	

Two-Way Sign Control Capacity Model: SIDRA Standard.  
 Gap-Acceptance Capacity Formula: SIDRA Standard (Akçelik M3D).

# SITE LAYOUT

▽ Site: [1] 2052 BG-DEV AM (Network Peak) (Murray Valley Highway / Heppell Road Intersection)

---

New Site

Site Category: (None)

Give-Way (Two-Way)

Site Scenario: 1 | Local Volumes

Layout pictures are schematic functional drawings reflecting input data. They are not design drawings.

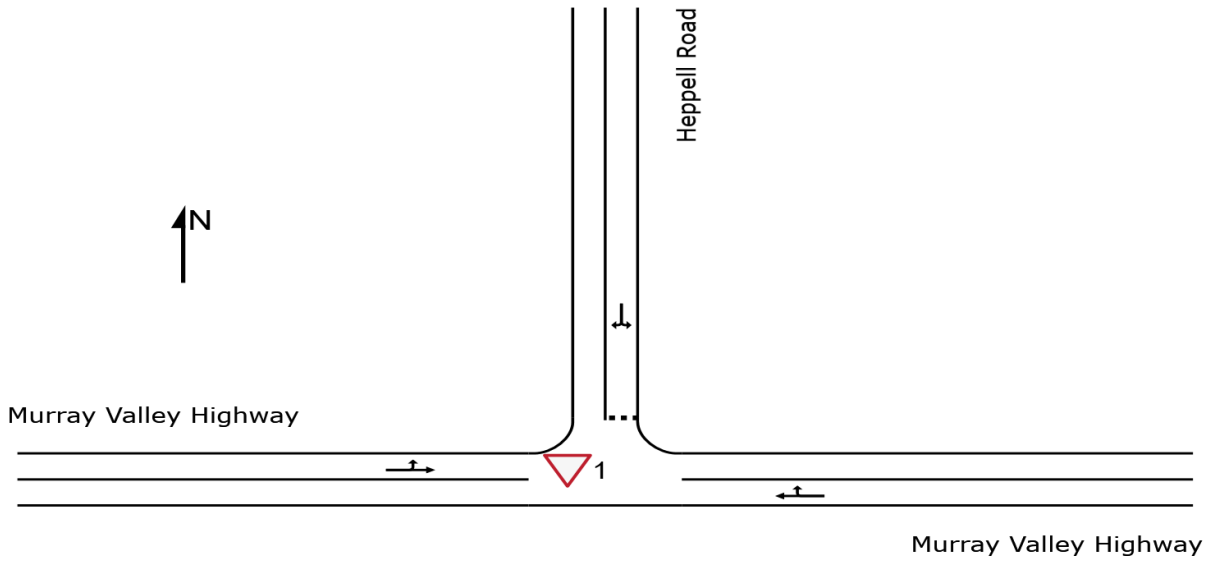

# MOVEMENT SUMMARY

Site: [1] 2052 BG-DEV AM (Network Peak) (Murray Valley Highway / Heppell Road Intersection)

Output produced by SIDRA INTERSECTION Version: 10.0.5.217

New Site

Site Category: (None)

Give-Way (Two-Way)

Site Scenario: 1 | Local Volumes

Vehicle Movement Performance													
Mov ID	Turn	Mov Class	Demand Flows	Arrival Flows	Deg. Satn	Aver. Delay	Level of Service	95% Back Of Queue		Prop. Qued	Eff. Stop Rate	Number of Cycles to Depart	Aver. Speed
			[ Total HV ]	[ Total HV ]	v/c	sec	[ Veh. Dist ]						km/h
			veh/h	%	veh/h	%			veh	m			
East: Murray Valley Highway													
5	T1	All MCs	243 27.7	243 27.7	0.155	0.1	LOS A	0.1	0.8	0.04	0.04	0.04	99.3
6	R2	All MCs	5 80.0	5 80.0	0.155	12.9	LOS B	0.1	0.8	0.04	0.04	0.04	57.5
Approach			248 28.8	248 28.8	0.155	0.4	NA	0.1	0.8	0.04	0.04	0.04	97.8
North: Heppell Road													
7	L2	All MCs	6 83.3	6 83.3	0.011	12.8	LOS B	0.0	0.4	0.48	0.67	0.48	49.9
9	R2	All MCs	1 0.0	1 0.0	0.011	10.4	LOS B	0.0	0.4	0.48	0.67	0.48	69.9
Approach			7 71.4	7 71.4	0.011	12.5	LOS B	0.0	0.4	0.48	0.67	0.48	52.1
West: Murray Valley Highway													
10	L2	All MCs	2 50.0	2 50.0	0.199	9.2	LOS A	0.0	0.0	0.00	0.00	0.00	67.1
11	T1	All MCs	357 12.1	357 12.1	0.199	0.0	LOS A	0.0	0.0	0.00	0.00	0.00	99.8
Approach			359 12.3	359 12.3	0.199	0.1	NA	0.0	0.0	0.00	0.00	0.00	99.5
All Vehicles			615 19.7	615 19.7	0.199	0.4	NA	0.1	0.8	0.02	0.03	0.02	97.8

Site Level of Service (LOS) Method: Delay (SIDRA). Site LOS Method is specified in the Parameter Settings dialog (Options tab).

Vehicle movement LOS values are based on average delay per movement.

Minor Road Approach LOS values are based on average delay for all vehicle movements.

NA (TWSC): Level of Service is not defined for major road approaches or the intersection as a whole for Two-Way Sign Control (HCM LOS rule).

Two-Way Sign Control Capacity Model: SIDRA Standard.

Delay Model: SIDRA Standard (Control Delay: Geometric Delay is included).

Queue Model: SIDRA queue estimation methods are used for Back of Queue and Queue at Start of Gap.

Gap-Acceptance Capacity Formula: SIDRA Standard (Akçelik M3D).

HV (%) values are calculated for All Movement Classes of All Heavy Vehicle Model Designation.

Arrival Flows used in performance calculations are adjusted to include any Initial Queued Demand and Upstream Capacity Constraint effects.

SIDRA INTERSECTION 10.0 | Copyright © 2000-2025 Akcelik and Associates Pty Ltd | sidrasolutions.com

Organisation: RMA ENGINEERS PTY LTD | Licence: NETWORK / 1PC | Processed: Monday, 21 July 2025 4:06:41 PM

Project: N:\Synergy\Projects\25E-0010 Poultry Farm - Torrumbarry\4 Design\Traffic\Sidra\Murray Valley Hwy - Heppell Rd.sipx

# MOVEMENT SUMMARY

Site: [1 (3)] 2052 BG-DEV AM (Development Peak 1) (Murray Valley Highway / Heppell Road Intersection)

Output produced by SIDRA INTERSECTION Version: 10.0.5.217

New Site

Site Category: (None)

Give-Way (Two-Way)

Site Scenario: 1 | Local Volumes

Vehicle Movement Performance															
Mov ID	Turn	Mov Class	Demand Flows		Arrival Flows		Deg. Satn	Aver. Delay	Level of Service	95% Back Of Queue		Prop. Qued	Eff. Stop of Cycles	Number of Cycles to Depart	Aver. Speed
			[ Total HV ]	[ Total HV ]	[ Total HV ]	[ Total HV ]	v/c	sec		[ Veh. ]	[ Dist ]		Rate	Rate	km/h
			veh/h	%	veh/h	%				veh	m				
East: Murray Valley Highway															
5	T1	All MCs	45	53.5	45	53.5	0.053	0.1	LOS A	0.2	1.7	0.14	0.32	0.14	87.4
6	R2	All MCs	39	8.1	39	8.1	0.053	7.9	LOS A	0.2	1.7	0.14	0.32	0.14	74.2
Approach			84	32.5	84	32.5	0.053	3.7	NA	0.2	1.7	0.14	0.32	0.14	80.8
North: Heppell Road															
7	L2	All MCs	6	16.7	6	16.7	0.005	8.5	LOS A	0.0	0.2	0.15	0.60	0.15	67.2
9	R2	All MCs	1	0.0	1	0.0	0.005	7.9	LOS A	0.0	0.2	0.15	0.60	0.15	72.8
Approach			7	14.3	7	14.3	0.005	8.4	LOS A	0.0	0.2	0.15	0.60	0.15	68.0
West: Murray Valley Highway															
10	L2	All MCs	11	10.0	11	10.0	0.039	8.1	LOS A	0.0	0.0	0.00	0.10	0.00	80.4
11	T1	All MCs	62	6.8	62	6.8	0.039	0.0	LOS A	0.0	0.0	0.00	0.10	0.00	97.0
Approach			73	7.2	73	7.2	0.039	1.2	NA	0.0	0.0	0.00	0.10	0.00	94.2
All Vehicles			164	20.5	164	20.5	0.053	2.8	NA	0.2	1.7	0.08	0.23	0.08	85.4

Site Level of Service (LOS) Method: Delay (SIDRA). Site LOS Method is specified in the Parameter Settings dialog (Options tab).

Vehicle movement LOS values are based on average delay per movement.

Minor Road Approach LOS values are based on average delay for all vehicle movements.

NA (TWSC): Level of Service is not defined for major road approaches or the intersection as a whole for Two-Way Sign Control (HCM LOS rule).

Two-Way Sign Control Capacity Model: SIDRA Standard.

Delay Model: SIDRA Standard (Control Delay: Geometric Delay is included).

Queue Model: SIDRA queue estimation methods are used for Back of Queue and Queue at Start of Gap.

Gap-Acceptance Capacity Formula: SIDRA Standard (Akçelik M3D).

HV (%) values are calculated for All Movement Classes of All Heavy Vehicle Model Designation.

Arrival Flows used in performance calculations are adjusted to include any Initial Queued Demand and Upstream Capacity Constraint effects.

SIDRA INTERSECTION 10.0 | Copyright © 2000-2025 Akcelik and Associates Pty Ltd | sidrasolutions.com

Organisation: RMA ENGINEERS PTY LTD | Licence: NETWORK / 1PC | Processed: Monday, 21 July 2025 4:06:41 PM

Project: N:\Synergy\Projects\25E-0010 Poultry Farm - Torrumbarry\4 Design\Traffic\Sidra\Murray Valley Hwy - Heppell Rd.sipx

# MOVEMENT SUMMARY

Site: [1 (5)] 2052 BG-DEV AM (Development Peak 2) (Murray Valley Highway / Heppell Road Intersection)

Output produced by SIDRA INTERSECTION Version: 10.0.5.217

New Site

Site Category: (None)

Give-Way (Two-Way)

Site Scenario: 1 | Local Volumes

Vehicle Movement Performance													
Mov ID	Turn	Mov Class	Demand Flows [ Total HV ]	Arrival Flows [ Total HV ]	Deg. Satn	Aver. Delay	Level of Service	95% Back Of Queue [ Veh. Dist ]		Prop. Qued	Eff. Stop of Cycles Rate to Depart	Number of Cycles	Aver. Speed
			veh/h %	veh/h %	v/c	sec		veh	m				km/h
East: Murray Valley Highway													
5	T1	All MCs	183 36.8	183 36.8	0.122	0.0	LOS A	0.1	0.6	0.03	0.03	0.03	99.4
6	R2	All MCs	5 80.0	5 80.0	0.122	10.3	LOS B	0.1	0.6	0.03	0.03	0.03	57.6
Approach			188 38.0	188 38.0	0.122	0.3	NA	0.1	0.6	0.03	0.03	0.03	97.5
North: Heppell Road													
7	L2	All MCs	6 83.3	6 83.3	0.008	10.9	LOS B	0.0	0.3	0.30	0.61	0.30	51.1
9	R2	All MCs	1 0.0	1 0.0	0.008	8.8	LOS A	0.0	0.3	0.30	0.61	0.30	72.2
Approach			7 71.4	7 71.4	0.008	10.6	LOS B	0.0	0.3	0.30	0.61	0.30	53.3
West: Murray Valley Highway													
10	L2	All MCs	2 50.0	2 50.0	0.084	9.1	LOS A	0.0	0.0	0.00	0.01	0.00	67.1
11	T1	All MCs	142 20.0	142 20.0	0.084	0.0	LOS A	0.0	0.0	0.00	0.01	0.00	99.8
Approach			144 20.4	144 20.4	0.084	0.1	NA	0.0	0.0	0.00	0.01	0.00	99.1
All Vehicles			340 31.3	340 31.3	0.122	0.5	NA	0.1	0.6	0.02	0.03	0.02	96.4

Site Level of Service (LOS) Method: Delay (SIDRA). Site LOS Method is specified in the Parameter Settings dialog (Options tab).

Vehicle movement LOS values are based on average delay per movement.

Minor Road Approach LOS values are based on average delay for all vehicle movements.

NA (TWSC): Level of Service is not defined for major road approaches or the intersection as a whole for Two-Way Sign Control (HCM LOS rule).

Two-Way Sign Control Capacity Model: SIDRA Standard.

Delay Model: SIDRA Standard (Control Delay: Geometric Delay is included).

Queue Model: SIDRA queue estimation methods are used for Back of Queue and Queue at Start of Gap.

Gap-Acceptance Capacity Formula: SIDRA Standard (Akçelik M3D).

HV (%) values are calculated for All Movement Classes of All Heavy Vehicle Model Designation.

Arrival Flows used in performance calculations are adjusted to include any Initial Queued Demand and Upstream Capacity Constraint effects.

SIDRA INTERSECTION 10.0 | Copyright © 2000-2025 Akcelik and Associates Pty Ltd | sidrasolutions.com

Organisation: RMA ENGINEERS PTY LTD | Licence: NETWORK / 1PC | Processed: Monday, 21 July 2025 4:06:41 PM

Project: N:\Synergy\Projects\25E-0010 Poultry Farm - Torrumbarry\4 Design\Traffic\Sidra\Murray Valley Hwy - Heppell Rd.sipx

# MOVEMENT SUMMARY

Site: [1 (2)] 2052 BG-DEV PM (Network Peak) (Murray Valley Highway / Heppell Road Intersection)

Output produced by SIDRA INTERSECTION Version: 10.0.5.217

New Site

Site Category: (None)

Give-Way (Two-Way)

Site Scenario: 1 | Local Volumes

Vehicle Movement Performance													
Mov ID	Turn	Mov Class	Demand Flows	Arrival Flows	Deg. Satn	Aver. Delay	Level of Service	95% Back Of Queue		Prop. Qued	Eff. Stop Rate	Number of Cycles to Depart	Aver. Speed
			[ Total HV ]	[ Total HV ]	v/c	sec	[ Veh. Dist ]						km/h
			veh/h	%	veh/h	%			veh	m			
East: Murray Valley Highway													
5	T1	All MCs	321 15.4	321 15.4	0.189	0.1	LOS A	0.1	0.7	0.03	0.03	0.03	99.5
6	R2	All MCs	5 80.0	5 80.0	0.189	11.8	LOS B	0.1	0.7	0.03	0.03	0.03	57.6
Approach			326 16.5	326 16.5	0.189	0.3	NA	0.1	0.7	0.03	0.03	0.03	98.4
North: Heppell Road													
7	L2	All MCs	6 83.3	6 83.3	0.010	12.1	LOS B	0.0	0.4	0.44	0.65	0.44	50.3
9	R2	All MCs	1 0.0	1 0.0	0.010	10.4	LOS B	0.0	0.4	0.44	0.65	0.44	70.7
Approach			7 71.4	7 71.4	0.010	11.9	LOS B	0.0	0.4	0.44	0.65	0.44	52.5
West: Murray Valley Highway													
10	L2	All MCs	2 50.0	2 50.0	0.166	9.1	LOS A	0.0	0.0	0.00	0.00	0.00	67.1
11	T1	All MCs	285 19.6	285 19.6	0.166	0.0	LOS A	0.0	0.0	0.00	0.00	0.00	99.8
Approach			287 19.8	287 19.8	0.166	0.1	NA	0.0	0.0	0.00	0.00	0.00	99.5
All Vehicles			621 18.6	621 18.6	0.189	0.3	NA	0.1	0.7	0.02	0.03	0.02	97.8

Site Level of Service (LOS) Method: Delay (SIDRA). Site LOS Method is specified in the Parameter Settings dialog (Options tab).

Vehicle movement LOS values are based on average delay per movement.

Minor Road Approach LOS values are based on average delay for all vehicle movements.

NA (TWSC): Level of Service is not defined for major road approaches or the intersection as a whole for Two-Way Sign Control (HCM LOS rule).

Two-Way Sign Control Capacity Model: SIDRA Standard.

Delay Model: SIDRA Standard (Control Delay: Geometric Delay is included).

Queue Model: SIDRA queue estimation methods are used for Back of Queue and Queue at Start of Gap.

Gap-Acceptance Capacity Formula: SIDRA Standard (Akçelik M3D).

HV (%) values are calculated for All Movement Classes of All Heavy Vehicle Model Designation.

Arrival Flows used in performance calculations are adjusted to include any Initial Queued Demand and Upstream Capacity Constraint effects.

SIDRA INTERSECTION 10.0 | Copyright © 2000-2025 Akcelik and Associates Pty Ltd | sidrasolutions.com

Organisation: RMA ENGINEERS PTY LTD | Licence: NETWORK / 1PC | Processed: Monday, 21 July 2025 4:06:41 PM

Project: N:\Synergy\Projects\25E-0010 Poultry Farm - Torrumbarry\4 Design\Traffic\Sidra\Murray Valley Hwy - Heppell Rd.sipx

# MOVEMENT SUMMARY

Site: [1 (4)] 2052 BG-DEV PM (Development Peak 1) (Murray Valley Highway / Heppell Road Intersection)

Output produced by SIDRA INTERSECTION Version: 10.0.5.217

New Site  
 Site Category: (None)  
 Give-Way (Two-Way)  
 Site Scenario: 1 | Local Volumes

Vehicle Movement Performance													
Mov ID	Turn	Mov Class	Demand Flows	Arrival Flows	Deg. Satn	Aver. Delay	Level of Service	95% Back Of Queue	Prop. Qued	Eff. Stop Rate	Number of Cycles to Depart	Aver. Speed	
			[ Total HV ]	[ Total HV ]	v/c	sec		[ Veh. ]	[ Dist ]			km/h	
			veh/h	%	veh/h	%		veh	m				
East: Murray Valley Highway													
5	T1	All MCs	244 13.8	244 13.8	0.145	0.1	LOS A	0.1	0.7	0.04	0.04	0.04	99.3
6	R2	All MCs	5 80.0	5 80.0	0.145	12.7	LOS B	0.1	0.7	0.04	0.04	0.04	57.5
Approach			249 15.2	249 15.2	0.145	0.4	NA	0.1	0.7	0.04	0.04	0.04	97.8
North: Heppell Road													
7	L2	All MCs	40 13.2	40 13.2	0.077	9.7	LOS A	0.3	2.2	0.47	0.73	0.47	65.7
9	R2	All MCs	18 47.1	18 47.1	0.077	14.2	LOS B	0.3	2.2	0.47	0.73	0.47	56.3
Approach			58 23.6	58 23.6	0.077	11.1	LOS B	0.3	2.2	0.47	0.73	0.47	62.5
West: Murray Valley Highway													
10	L2	All MCs	2 50.0	2 50.0	0.194	9.2	LOS A	0.0	0.0	0.00	0.00	0.00	67.1
11	T1	All MCs	328 21.8	328 21.8	0.194	0.0	LOS A	0.0	0.0	0.00	0.00	0.00	99.8
Approach			331 22.0	331 22.0	0.194	0.1	NA	0.0	0.0	0.00	0.00	0.00	99.5
All Vehicles			638 19.5	638 19.5	0.194	1.2	NA	0.3	2.2	0.06	0.08	0.06	93.8

Site Level of Service (LOS) Method: Delay (SIDRA). Site LOS Method is specified in the Parameter Settings dialog (Options tab).  
 Vehicle movement LOS values are based on average delay per movement.  
 Minor Road Approach LOS values are based on average delay for all vehicle movements.  
 NA (TWSC): Level of Service is not defined for major road approaches or the intersection as a whole for Two-Way Sign Control (HCM LOS rule).  
 Two-Way Sign Control Capacity Model: SIDRA Standard.  
 Delay Model: SIDRA Standard (Control Delay: Geometric Delay is included).  
 Queue Model: SIDRA queue estimation methods are used for Back of Queue and Queue at Start of Gap.  
 Gap-Acceptance Capacity Formula: SIDRA Standard (Akçelik M3D).  
 HV (%) values are calculated for All Movement Classes of All Heavy Vehicle Model Designation.  
 Arrival Flows used in performance calculations are adjusted to include any Initial Queued Demand and Upstream Capacity Constraint effects.

# MOVEMENT SUMMARY

Site: [1 (6)] 2052 BG-DEV PM (Development Peak 2) (Murray Valley Highway / Heppell Road Intersection)

Output produced by SIDRA INTERSECTION Version: 10.0.5.217

New Site

Site Category: (None)

Give-Way (Two-Way)

Site Scenario: 1 | Local Volumes

Vehicle Movement Performance													
Mov ID	Turn	Mov Class	Demand Flows	Arrival Flows	Deg. Satn	Aver. Delay	Level of Service	95% Back Of Queue		Prop. Qued	Eff. Stop of Cycles	Number of Cycles	Aver. Speed
			[ Total HV ]	[ Total HV ]	v/c	sec	[ Veh. Dist ]				Rate to Depart	km/h	
			veh/h	%	veh/h	%			veh	m			
East: Murray Valley Highway													
5	T1	All MCs	355 13.4	355 13.4	0.205	0.0	LOS A	0.1	0.6	0.02	0.02	0.02	99.6
6	R2	All MCs	5 80.0	5 80.0	0.205	11.2	LOS B	0.1	0.6	0.02	0.02	0.02	57.6
Approach			360 14.3	360 14.3	0.205	0.2	NA	0.1	0.6	0.02	0.02	0.02	98.5
North: Heppell Road													
7	L2	All MCs	6 83.3	6 83.3	0.010	11.9	LOS B	0.0	0.4	0.42	0.64	0.42	50.5
9	R2	All MCs	1 0.0	1 0.0	0.010	10.5	LOS B	0.0	0.4	0.42	0.64	0.42	71.0
Approach			7 71.4	7 71.4	0.010	11.7	LOS B	0.0	0.4	0.42	0.64	0.42	52.7
West: Murray Valley Highway													
10	L2	All MCs	2 50.0	2 50.0	0.150	9.1	LOS A	0.0	0.0	0.00	0.01	0.00	67.1
11	T1	All MCs	258 18.8	258 18.8	0.150	0.0	LOS A	0.0	0.0	0.00	0.01	0.00	99.8
Approach			260 19.0	260 19.0	0.150	0.1	NA	0.0	0.0	0.00	0.01	0.00	99.4
All Vehicles			627 16.9	627 16.9	0.205	0.3	NA	0.1	0.6	0.02	0.02	0.02	97.9

Site Level of Service (LOS) Method: Delay (SIDRA). Site LOS Method is specified in the Parameter Settings dialog (Options tab).

Vehicle movement LOS values are based on average delay per movement.

Minor Road Approach LOS values are based on average delay for all vehicle movements.

NA (TWSC): Level of Service is not defined for major road approaches or the intersection as a whole for Two-Way Sign Control (HCM LOS rule).

Two-Way Sign Control Capacity Model: SIDRA Standard.

Delay Model: SIDRA Standard (Control Delay: Geometric Delay is included).

Queue Model: SIDRA queue estimation methods are used for Back of Queue and Queue at Start of Gap.

Gap-Acceptance Capacity Formula: SIDRA Standard (Akçelik M3D).

HV (%) values are calculated for All Movement Classes of All Heavy Vehicle Model Designation.

Arrival Flows used in performance calculations are adjusted to include any Initial Queued Demand and Upstream Capacity Constraint effects.

SIDRA INTERSECTION 10.0 | Copyright © 2000-2025 Akcelik and Associates Pty Ltd | sidrasolutions.com

Organisation: RMA ENGINEERS PTY LTD | Licence: NETWORK / 1PC | Processed: Monday, 21 July 2025 4:06:42 PM

Project: N:\Synergy\Projects\25E-0010 Poultry Farm - Torrumbarry\4 Design\Traffic\Sidra\Murray Valley Hwy - Heppell Rd.sipx

# SIGN CONTROL ANALYSIS

Site: [1] 2052 BG-DEV AM (Network Peak) (Murray Valley Highway / Heppell Road Intersection)

Output produced by SIDRA INTERSECTION Version: 10.0.5.217

New Site

Site Category: (None)

Give-Way (Two-Way)

Site Scenario: 1 | Local Volumes

Sign Control Basic Parameters					
Approach Control	Leg Geometry	App. Dist m	Prop Queued Upstr Signal	Extra Bunching %	
East: Murray Valley Highway					
Major Road	Two Way	500.0	NA <sup>5</sup>	0.0 <sup>3</sup>	
North: Heppell Road					
Give-Way	Two Way	500.0	NA <sup>5</sup>	0.0 <sup>3</sup>	
West: Murray Valley Highway					
Major Road	Two Way	500.0	NA <sup>5</sup>	0.0 <sup>3</sup>	

Two-Way Sign Control Capacity Model: SIDRA Standard.

Gap-Acceptance Capacity Formula: SIDRA Standard (Akçelik M3D).

<sup>3</sup> User-specified Extra Bunching

<sup>5</sup> Not Applicable (single Site analysis or unconnected Site in Network analysis).

Gap Acceptance Parameters												
Opposed Lane	Dest	Turn	Apply Calib	Opng Flow veh/h	Opng Flow pcu/h	In-Bunch Hdw sec	Prop. Bunched	Gap Acc Factor	Critical Gap [ Hdw sec	Gap (tc) Dist ] m	Follow-up Hdw (tf) sec	Ratio tf / tc
East: Murray Valley Highway												
1	North	R2	Y	359 <sup>14</sup>	381 <sup>14</sup>	1.80	0.045	1.40	5.60	154.8	2.80	0.50
North: Heppell Road												
1	East	L2	Y	357	378	1.80	0.045	1.42	5.67	157.4	3.12	0.55
1	West	R2	Y	606 <sup>14</sup>	664 <sup>14</sup>	1.00	0.043	1.00	4.30	118.6	2.80	0.65
West: Murray Valley Highway												
No opposed movements on this approach.												

Two-Way Sign Control Capacity Model: SIDRA Standard.

Gap-Acceptance Capacity Formula: SIDRA Standard (Akçelik M3D).

Values in this table are adjusted for movement classes in the entry stream.

Use the Pedestrians and Priorities input dialogs to specify opposing pedestrian movements.

<sup>14</sup> Percentage of exiting flow included in opposing vehicle flow

Gap Acceptance Cycle Parameters (Lanes)					
Opposed Lane	Cycle Time sec	Blocked Time sec	Unblocked Time sec	Unblocked Time Ratio	Minimum Delay sec
East: Murray Valley Highway					
1	15.90	6.49	9.41	0.592	0.2
North: Heppell Road					
1	15.43	6.32	9.12	0.591	2.5
West: Murray Valley Highway					

No opposed movements on this approach.

Two-Way Sign Control Capacity Model: SIDRA Standard.

Gap-Acceptance Capacity Formula: SIDRA Standard (Akçelik M3D).

Gap Acceptance Cycle Parameters (Movements)							
To Approach	Turn	Lane No	Cycle Time sec	Blocked Time sec	Unblocked Time sec	Unblocked Time Ratio	Minimum Delay sec
East: Murray Valley Highway							
North	R2	1	15.90	6.49	9.41	0.592	2.5
North: Heppell Road							
East	L2	1	16.07	6.44	9.63	0.599	2.5
West	R2	1	11.57	5.55	6.02	0.520	2.7
West: Murray Valley Highway							
No opposed movements on this approach.							

Two-Way Sign Control Capacity Model: SIDRA Standard.

Gap-Acceptance Capacity Formula: SIDRA Standard (Akçelik M3D).

# SIGN CONTROL ANALYSIS

Site: [1 (3)] 2052 BG-DEV AM (Development Peak 1) (Murray Valley Highway / Heppell Road Intersection)

Output produced by SIDRA INTERSECTION Version: 10.0.5.217

New Site

Site Category: (None)

Give-Way (Two-Way)

Site Scenario: 1 | Local Volumes

Sign Control Basic Parameters					
Approach Control	Leg Geometry	App. Dist m	Prop Queued Upstr Signal	Extra Bunching %	
East: Murray Valley Highway					
Major Road	Two Way	500.0	NA <sup>5</sup>	0.0 <sup>3</sup>	
North: Heppell Road					
Give-Way	Two Way	500.0	NA <sup>5</sup>	0.0 <sup>3</sup>	
West: Murray Valley Highway					
Major Road	Two Way	500.0	NA <sup>5</sup>	0.0 <sup>3</sup>	

Two-Way Sign Control Capacity Model: SIDRA Standard.

Gap-Acceptance Capacity Formula: SIDRA Standard (Akçelik M3D).

<sup>3</sup> User-specified Extra Bunching

<sup>5</sup> Not Applicable (single Site analysis or unconnected Site in Network analysis).

Gap Acceptance Parameters												
Opposed Lane	Dest	Turn	Apply Calib	Opng Flow veh/h	Opng Flow pcu/h	In-Bunch Hdwy sec	Prop. Bunched	Gap Acc Factor	Critical Gap [ Hdwy Dist ] sec	Follow-up Hdwy (tf) m	Ratio tf / tc	
East: Murray Valley Highway												
1	North	R2	Y	73 <sup>14</sup>	75 <sup>14</sup>	1.80	0.008	1.04	4.16	102.2	2.08	0.50
North: Heppell Road												
1	East	L2	Y	62	64	1.80	0.007	1.08	4.33	120.4	2.38	0.55
1	West	R2	Y	152 <sup>14</sup>	168 <sup>14</sup>	1.01	0.010	1.00	4.30	93.1	2.80	0.65
West: Murray Valley Highway												
No opposed movements on this approach.												

Two-Way Sign Control Capacity Model: SIDRA Standard.

Gap-Acceptance Capacity Formula: SIDRA Standard (Akçelik M3D).

Values in this table are adjusted for movement classes in the entry stream.

Use the Pedestrians and Priorities input dialogs to specify opposing pedestrian movements.

<sup>14</sup> Percentage of exiting flow included in opposing vehicle flow

Gap Acceptance Cycle Parameters (Lanes)					
Opposed Lane	Cycle Time sec	Blocked Time sec	Unblocked Time sec	Unblocked Time Ratio	Minimum Delay sec
East: Murray Valley Highway					
1	50.72	3.29	47.43	0.935	0.2
North: Heppell Road					
1	54.30	3.31	51.00	0.939	0.2
West: Murray Valley Highway					

No opposed movements on this approach.

Two-Way Sign Control Capacity Model: SIDRA Standard.

Gap-Acceptance Capacity Formula: SIDRA Standard (Akçelik M3D).

Gap Acceptance Cycle Parameters (Movements)							
To Approach	Turn	Lane No	Cycle Time sec	Blocked Time sec	Unblocked Time sec	Unblocked Time Ratio	Minimum Delay sec
East: Murray Valley Highway							
North	R2	1	50.72	3.29	47.43	0.935	0.2
North: Heppell Road							
East	L2	1	59.12	3.30	55.82	0.944	0.2
West	R2	1	25.43	3.36	22.06	0.868	0.5
West: Murray Valley Highway							
No opposed movements on this approach.							

Two-Way Sign Control Capacity Model: SIDRA Standard.

Gap-Acceptance Capacity Formula: SIDRA Standard (Akçelik M3D).

# SIGN CONTROL ANALYSIS

Site: [1 (5)] 2052 BG-DEV AM (Development Peak 2) (Murray Valley Highway / Heppell Road Intersection)

Output produced by SIDRA INTERSECTION Version: 10.0.5.217

New Site

Site Category: (None)

Give-Way (Two-Way)

Site Scenario: 1 | Local Volumes

Sign Control Basic Parameters					
Approach Control	Leg Geometry	App. Dist m	Prop Queued Upstr Signal	Extra Bunching %	
East: Murray Valley Highway					
Major Road	Two Way	500.0	NA <sup>5</sup>	0.0 <sup>3</sup>	
North: Heppell Road					
Give-Way	Two Way	500.0	NA <sup>5</sup>	0.0 <sup>3</sup>	
West: Murray Valley Highway					
Major Road	Two Way	500.0	NA <sup>5</sup>	0.0 <sup>3</sup>	

Two-Way Sign Control Capacity Model: SIDRA Standard.

Gap-Acceptance Capacity Formula: SIDRA Standard (Akçelik M3D).

<sup>3</sup> User-specified Extra Bunching

<sup>5</sup> Not Applicable (single Site analysis or unconnected Site in Network analysis).

Gap Acceptance Parameters												
Opposed Lane	Dest	Turn	Apply Calib	Opng Flow veh/h	Opng Flow pcu/h	In-Bunch Hdwy sec	Prop. Bunched	Gap Acc Factor	Critical Gap [Hdwy Dist] sec	Gap (tc) Dist m	Follow-up Hdwy (tf) sec	Ratio tf / tc
East: Murray Valley Highway												
1	North	R2	Y	144 <sup>14</sup>	159 <sup>14</sup>	1.80	0.017	1.40	5.60	153.7	2.80	0.50
North: Heppell Road												
1	East	L2	Y	142	156	1.80	0.017	1.42	5.67	157.4	3.12	0.55
1	West	R2	Y	332 <sup>14</sup>	382 <sup>14</sup>	1.02	0.024	1.00	4.30	117.9	2.80	0.65
West: Murray Valley Highway												
No opposed movements on this approach.												

Two-Way Sign Control Capacity Model: SIDRA Standard.

Gap-Acceptance Capacity Formula: SIDRA Standard (Akçelik M3D).

Values in this table are adjusted for movement classes in the entry stream.

Use the Pedestrians and Priorities input dialogs to specify opposing pedestrian movements.

<sup>14</sup> Percentage of exiting flow included in opposing vehicle flow

Gap Acceptance Cycle Parameters (Lanes)					
Opposed Lane	Cycle Time sec	Blocked Time sec	Unblocked Time sec	Unblocked Time Ratio	Minimum Delay sec
East: Murray Valley Highway					
1	27.56	4.95	22.61	0.820	0.1
North: Heppell Road					
1	26.03	4.76	21.27	0.817	0.9
West: Murray Valley Highway					

No opposed movements on this approach.

Two-Way Sign Control Capacity Model: SIDRA Standard.

Gap-Acceptance Capacity Formula: SIDRA Standard (Akçelik M3D).

Gap Acceptance Cycle Parameters (Movements)							
To Approach	Turn	Lane No	Cycle Time sec	Blocked Time sec	Unblocked Time sec	Unblocked Time Ratio	Minimum Delay sec
East: Murray Valley Highway							
North	R2	1	27.56	4.95	22.61	0.820	0.8
North: Heppell Road							
East	L2	1	28.01	4.87	23.15	0.826	0.8
West	R2	1	14.13	4.12	10.01	0.708	1.3
West: Murray Valley Highway							
No opposed movements on this approach.							

Two-Way Sign Control Capacity Model: SIDRA Standard.

Gap-Acceptance Capacity Formula: SIDRA Standard (Akçelik M3D).

# SIGN CONTROL ANALYSIS

Site: [1 (2)] 2052 BG-DEV PM (Network Peak) (Murray Valley Highway / Heppell Road Intersection)

Output produced by SIDRA INTERSECTION Version: 10.0.5.217

New Site

Site Category: (None)

Give-Way (Two-Way)

Site Scenario: 1 | Local Volumes

Sign Control Basic Parameters					
Approach Control	Leg Geometry	App. Dist m	Prop Queued Upstr Signal	Extra Bunching %	
East: Murray Valley Highway					
Major Road	Two Way	500.0	NA <sup>5</sup>	0.0 <sup>3</sup>	
North: Heppell Road					
Give-Way	Two Way	500.0	NA <sup>5</sup>	0.0 <sup>3</sup>	
West: Murray Valley Highway					
Major Road	Two Way	500.0	NA <sup>5</sup>	0.0 <sup>3</sup>	

Two-Way Sign Control Capacity Model: SIDRA Standard.

Gap-Acceptance Capacity Formula: SIDRA Standard (Akçelik M3D).

<sup>3</sup> User-specified Extra Bunching

<sup>5</sup> Not Applicable (single Site analysis or unconnected Site in Network analysis).

Gap Acceptance Parameters												
Opposed Lane	Dest	Turn	Apply Calib	Opng Flow veh/h	Opng Flow pcu/h	In-Bunch Hdwy sec	Prop. Bunched	Gap Acc Factor	Critical Gap (tc) [ Hdwy Dist ] sec	Follow-up Hdwy (tf) m	Ratio tf / tc sec	
East: Murray Valley Highway												
1	North	R2	Y	287 <sup>14</sup>	316 <sup>14</sup>	1.80	0.036	1.40	5.60	154.6	2.80	0.50
North: Heppell Road												
1	East	L2	Y	285	313	1.80	0.036	1.42	5.67	157.4	3.12	0.55
1	West	R2	Y	613 <sup>14</sup>	668 <sup>14</sup>	0.94	0.041	1.00	4.30	118.6	2.80	0.65
West: Murray Valley Highway												
No opposed movements on this approach.												

Two-Way Sign Control Capacity Model: SIDRA Standard.

Gap-Acceptance Capacity Formula: SIDRA Standard (Akçelik M3D).

Values in this table are adjusted for movement classes in the entry stream.

Use the Pedestrians and Priorities input dialogs to specify opposing pedestrian movements.

<sup>14</sup> Percentage of exiting flow included in opposing vehicle flow

Gap Acceptance Cycle Parameters (Lanes)					
Opposed Lane	Cycle Time sec	Blocked Time sec	Unblocked Time sec	Unblocked Time Ratio	Minimum Delay sec
East: Murray Valley Highway					
1	17.32	5.96	11.36	0.656	0.1
North: Heppell Road					
1	16.67	5.85	10.82	0.649	2.0
West: Murray Valley Highway					

No opposed movements on this approach.

Two-Way Sign Control Capacity Model: SIDRA Standard.

Gap-Acceptance Capacity Formula: SIDRA Standard (Akçelik M3D).

Gap Acceptance Cycle Parameters (Movements)							
To Approach	Turn	Lane No	Cycle Time sec	Blocked Time sec	Unblocked Time sec	Unblocked Time Ratio	Minimum Delay sec
East: Murray Valley Highway							
North	R2	1	17.32	5.96	11.36	0.656	1.9
North: Heppell Road							
East	L2	1	17.51	5.90	11.61	0.663	1.9
West	R2	1	11.59	5.55	6.04	0.521	2.7
West: Murray Valley Highway							
No opposed movements on this approach.							

Two-Way Sign Control Capacity Model: SIDRA Standard.

Gap-Acceptance Capacity Formula: SIDRA Standard (Akçelik M3D).

# SIGN CONTROL ANALYSIS

Site: [1 (4)] 2052 BG-DEV PM (Development Peak 1) (Murray Valley Highway / Heppell Road Intersection)

Output produced by SIDRA INTERSECTION Version: 10.0.5.217

New Site

Site Category: (None)

Give-Way (Two-Way)

Site Scenario: 1 | Local Volumes

Sign Control Basic Parameters					
Approach Control	Leg Geometry	App. Dist m	Prop Queued Upstr Signal	Extra Bunching %	
East: Murray Valley Highway					
Major Road	Two Way	500.0	NA <sup>5</sup>	0.0 <sup>3</sup>	
North: Heppell Road					
Give-Way	Two Way	500.0	NA <sup>5</sup>	0.0 <sup>3</sup>	
West: Murray Valley Highway					
Major Road	Two Way	500.0	NA <sup>5</sup>	0.0 <sup>3</sup>	

Two-Way Sign Control Capacity Model: SIDRA Standard.

Gap-Acceptance Capacity Formula: SIDRA Standard (Akçelik M3D).

<sup>3</sup> User-specified Extra Bunching

<sup>5</sup> Not Applicable (single Site analysis or unconnected Site in Network analysis).

Gap Acceptance Parameters												
Opposed Lane	Dest	Turn	Apply Calib	Opng Flow veh/h	Opng Flow pcu/h	In-Bunch Hdwy sec	Prop. Bunched	Gap Acc Factor	Critical Gap (tc) [ Hdwy Dist ] sec	Follow-up Hdwy (tf) m	Ratio tf / tc sec	
East: Murray Valley Highway												
1	North	R2	Y	331 <sup>14</sup>	367 <sup>14</sup>	1.80	0.043	1.40	5.60	154.8	2.80	0.50
North: Heppell Road												
1	East	L2	Y	328	364	1.80	0.043	1.07	4.26	118.4	2.34	0.55
1	West	R2	Y	579 <sup>14</sup>	634 <sup>14</sup>	1.00	0.041	1.24	5.31	146.4	3.46	0.65
West: Murray Valley Highway												
No opposed movements on this approach.												

Two-Way Sign Control Capacity Model: SIDRA Standard.

Gap-Acceptance Capacity Formula: SIDRA Standard (Akçelik M3D).

Values in this table are adjusted for movement classes in the entry stream.

Use the Pedestrians and Priorities input dialogs to specify opposing pedestrian movements.

<sup>14</sup> Percentage of exiting flow included in opposing vehicle flow

Gap Acceptance Cycle Parameters (Lanes)					
Opposed Lane	Cycle Time sec	Blocked Time sec	Unblocked Time sec	Unblocked Time Ratio	Minimum Delay sec
East: Murray Valley Highway					
1	16.14	6.37	9.77	0.605	0.2
North: Heppell Road					
1	13.98	5.29	8.69	0.621	2.3
West: Murray Valley Highway					

No opposed movements on this approach.

Two-Way Sign Control Capacity Model: SIDRA Standard.

Gap-Acceptance Capacity Formula: SIDRA Standard (Akçelik M3D).

Gap Acceptance Cycle Parameters (Movements)							
To Approach	Turn	Lane No	Cycle Time sec	Blocked Time sec	Unblocked Time sec	Unblocked Time Ratio	Minimum Delay sec
East: Murray Valley Highway							
North	R2	1	16.14	6.37	9.77	0.605	2.3
North: Heppell Road							
East	L2	1	13.82	4.20	9.62	0.696	1.3
West	R2	1	14.33	7.73	6.60	0.461	4.5
West: Murray Valley Highway							
No opposed movements on this approach.							

Two-Way Sign Control Capacity Model: SIDRA Standard.

Gap-Acceptance Capacity Formula: SIDRA Standard (Akçelik M3D).

# SIGN CONTROL ANALYSIS

Site: [1 (6)] 2052 BG-DEV PM (Development Peak 2) (Murray Valley Highway / Heppell Road Intersection)

Output produced by SIDRA INTERSECTION Version: 10.0.5.217

New Site

Site Category: (None)

Give-Way (Two-Way)

Site Scenario: 1 | Local Volumes

Sign Control Basic Parameters					
Approach Control	Leg Geometry	App. Dist m	Prop Queued Upstr Signal	Extra Bunching %	
East: Murray Valley Highway					
Major Road	Two Way	500.0	NA <sup>5</sup>	0.0 <sup>3</sup>	
North: Heppell Road					
Give-Way	Two Way	500.0	NA <sup>5</sup>	0.0 <sup>3</sup>	
West: Murray Valley Highway					
Major Road	Two Way	500.0	NA <sup>5</sup>	0.0 <sup>3</sup>	

Two-Way Sign Control Capacity Model: SIDRA Standard.

Gap-Acceptance Capacity Formula: SIDRA Standard (Akçelik M3D).

<sup>3</sup> User-specified Extra Bunching

<sup>5</sup> Not Applicable (single Site analysis or unconnected Site in Network analysis).

Gap Acceptance Parameters												
Opposed Lane	Dest	Turn	Apply Calib	Opng Flow veh/h	Opng Flow pcu/h	In-Bunch Hdwy sec	Prop. Bunched	Gap Acc Factor	Critical Gap [Hdwy Dist] sec	Gap (tc) Dist m	Follow-up Hdwy (tf) sec	Ratio tf / tc
East: Murray Valley Highway												
1	North	R2	Y	260 <sup>14</sup>	285 <sup>14</sup>	1.80	0.032	1.40	5.60	154.6	2.80	0.50
North: Heppell Road												
1	East	L2	Y	258	282	1.80	0.032	1.42	5.67	157.4	3.12	0.55
1	West	R2	Y	619 <sup>14</sup>	669 <sup>14</sup>	1.00	0.044	1.00	4.30	118.6	2.80	0.65
West: Murray Valley Highway												
No opposed movements on this approach.												

Two-Way Sign Control Capacity Model: SIDRA Standard.

Gap-Acceptance Capacity Formula: SIDRA Standard (Akçelik M3D).

Values in this table are adjusted for movement classes in the entry stream.

Use the Pedestrians and Priorities input dialogs to specify opposing pedestrian movements.

<sup>14</sup> Percentage of exiting flow included in opposing vehicle flow

Gap Acceptance Cycle Parameters (Lanes)					
Opposed Lane	Cycle Time sec	Blocked Time sec	Unblocked Time sec	Unblocked Time Ratio	Minimum Delay sec
East: Murray Valley Highway					
1	18.34	5.73	12.60	0.687	0.1
North: Heppell Road					
1	17.55	5.66	11.89	0.678	1.8
West: Murray Valley Highway					

No opposed movements on this approach.

Two-Way Sign Control Capacity Model: SIDRA Standard.

Gap-Acceptance Capacity Formula: SIDRA Standard (Akçelik M3D).

Gap Acceptance Cycle Parameters (Movements)							
To Approach	Turn	Lane No	Cycle Time sec	Blocked Time sec	Unblocked Time sec	Unblocked Time Ratio	Minimum Delay sec
East: Murray Valley Highway							
North	R2	1	18.34	5.73	12.60	0.687	1.7
North: Heppell Road							
East	L2	1	18.55	5.67	12.88	0.694	1.7
West	R2	1	11.56	5.59	5.98	0.517	2.7
West: Murray Valley Highway							
No opposed movements on this approach.							

Two-Way Sign Control Capacity Model: SIDRA Standard.

Gap-Acceptance Capacity Formula: SIDRA Standard (Akçelik M3D).

# SITE LAYOUT

▽ Site: [1] 2052 BG-DEV AM (Network Peak) (Murray Valley Hwy/  
Roslynmead Rd/Bail Rd Intersection)

New Site  
Site Category: (None)  
Give-Way (Two-Way)  
Site Scenario: 1 | Local Volumes

Layout pictures are schematic functional drawings reflecting input data. They are not design drawings.

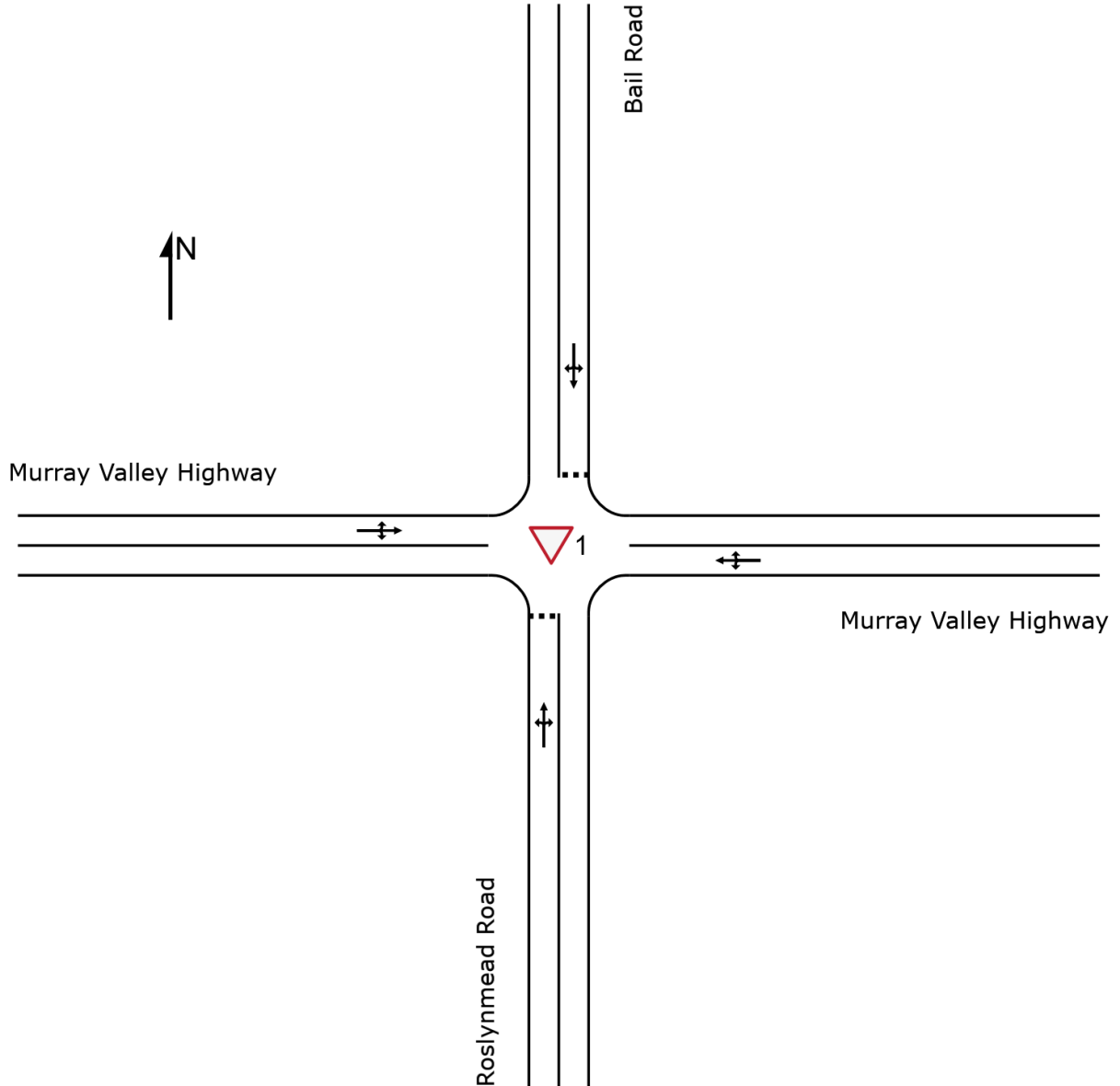

# MOVEMENT SUMMARY

Site: [1] 2052 BG-DEV AM (Network Peak) (Murray Valley Hwy/ Roslynmead Rd/Bail Rd Intersection)

Output produced by SIDRA INTERSECTION Version: 10.0.5.217

New Site  
 Site Category: (None)  
 Give-Way (Two-Way)  
 Site Scenario: 1 | Local Volumes

Vehicle Movement Performance													
Mov ID	Turn	Mov Class	Demand Flows	Arrival Flows	Deg. Satn	Aver. Delay	Level of Service	95% Back Of Queue	Prop. Qued	Eff. Stop Rate	Number of Cycles to Depart	Aver. Speed	
			[ Total HV ]	[ Total HV ]	v/c	sec		[ Veh. Dist ]				km/h	
			veh/h	%	veh/h	%		veh	m				
South: Roslynmead Road													
1	L2	All MCs	32 46.7	32 46.7	0.035	10.3	LOS B	0.1	1.3	0.36	0.64	0.36	58.3
2	T1	All MCs	1 0.0	1 0.0	0.035	9.9	LOS A	0.1	1.3	0.36	0.64	0.36	71.7
3	R2	All MCs	1 0.0	1 0.0	0.035	11.6	LOS B	0.1	1.3	0.36	0.64	0.36	71.6
Approach			34 43.8	34 43.8	0.035	10.3	LOS B	0.1	1.3	0.36	0.64	0.36	59.0
East: Murray Valley Highway													
4	L2	All MCs	2 0.0	2 0.0	0.129	8.1	LOS A	0.0	0.2	0.01	0.02	0.01	86.9
5	T1	All MCs	212 25.9	212 25.9	0.129	0.0	LOS A	0.0	0.2	0.01	0.02	0.01	99.3
6	R2	All MCs	2 0.0	2 0.0	0.129	7.9	LOS A	0.0	0.2	0.01	0.02	0.01	86.8
Approach			216 25.4	216 25.4	0.129	0.2	NA	0.0	0.2	0.01	0.02	0.01	99.0
North: Bail Road													
7	L2	All MCs	2 0.0	2 0.0	0.023	9.0	LOS A	0.1	0.7	0.56	0.76	0.56	65.9
8	T1	All MCs	3 66.7	3 66.7	0.023	15.0	LOS B	0.1	0.7	0.56	0.76	0.56	51.9
9	R2	All MCs	4 50.0	4 50.0	0.023	17.0	LOS C	0.1	0.7	0.56	0.76	0.56	53.1
Approach			9 44.4	9 44.4	0.023	14.5	LOS B	0.1	0.7	0.56	0.76	0.56	55.0
West: Murray Valley Highway													
10	L2	All MCs	1 0.0	1 0.0	0.212	9.2	LOS A	0.3	2.6	0.09	0.11	0.09	85.4
11	T1	All MCs	331 10.8	331 10.8	0.212	0.2	LOS A	0.3	2.6	0.09	0.11	0.09	97.4
12	R2	All MCs	31 37.9	31 37.9	0.212	9.9	LOS A	0.3	2.6	0.09	0.11	0.09	69.0
Approach			362 13.1	362 13.1	0.212	1.0	NA	0.3	2.6	0.09	0.11	0.09	94.1
All Vehicles			621 19.5	621 19.5	0.212	1.4	NA	0.3	2.6	0.09	0.12	0.09	91.7

Site Level of Service (LOS) Method: Delay (SIDRA). Site LOS Method is specified in the Parameter Settings dialog (Options tab).  
 Vehicle movement LOS values are based on average delay per movement.  
 Minor Road Approach LOS values are based on average delay for all vehicle movements.  
 NA (TWSC): Level of Service is not defined for major road approaches or the intersection as a whole for Two-Way Sign Control (HCM LOS rule).  
 Two-Way Sign Control Capacity Model: SIDRA Standard.  
 Delay Model: SIDRA Standard (Control Delay: Geometric Delay is included).  
 Queue Model: SIDRA queue estimation methods are used for Back of Queue and Queue at Start of Gap.  
 Gap-Acceptance Capacity Formula: SIDRA Standard (Akçelik M3D).  
 HV (%) values are calculated for All Movement Classes of All Heavy Vehicle Model Designation.  
 Arrival Flows used in performance calculations are adjusted to include any Initial Queued Demand and Upstream Capacity Constraint effects.

# MOVEMENT SUMMARY

Site: [2] 2052 BG-DEV AM (Development Peak 1) (Murray Valley Hwy/Roslynmead Rd/Bail Rd Intersection)

Output produced by SIDRA INTERSECTION Version: 10.0.5.217

New Site  
 Site Category: (None)  
 Give-Way (Two-Way)  
 Site Scenario: 1 | Local Volumes

Vehicle Movement Performance													
Mov ID	Turn	Mov Class	Demand Flows	Arrival Flows	Deg. Satn	Aver. Delay	Level of Service	95% Back Of Queue		Prop. Qued	Eff. Stop Rate	Number of Cycles to Depart	Aver. Speed
			[ Total HV ]	[ Total HV ]	v/c	sec	[ Veh. Dist ]						km/h
			veh/h	%	veh/h	%			veh	m			
South: Roslynmead Road													
1	L2	All MCs	8 75.0	8 75.0	0.011	10.2	LOS B	0.0	0.4	0.21	0.61	0.21	53.0
2	T1	All MCs	1 0.0	1 0.0	0.011	7.3	LOS A	0.0	0.4	0.21	0.61	0.21	73.1
3	R2	All MCs	2 0.0	2 0.0	0.011	8.2	LOS A	0.0	0.4	0.21	0.61	0.21	73.0
Approach			12 54.5	12 54.5	0.011	9.6	LOS A	0.0	0.4	0.21	0.61	0.21	57.3
East: Murray Valley Highway													
4	L2	All MCs	37 0.0	37 0.0	0.066	7.8	LOS A	0.0	0.1	0.00	0.23	0.00	81.0
5	T1	All MCs	75 29.6	75 29.6	0.066	0.0	LOS A	0.0	0.1	0.00	0.23	0.00	91.7
6	R2	All MCs	1 0.0	1 0.0	0.066	7.4	LOS A	0.0	0.1	0.00	0.23	0.00	81.0
Approach			113 19.6	113 19.6	0.066	2.6	NA	0.0	0.1	0.00	0.23	0.00	87.8
North: Bail Road													
7	L2	All MCs	4 0.0	4 0.0	0.005	7.9	LOS A	0.0	0.1	0.14	0.60	0.14	74.0
8	T1	All MCs	1 0.0	1 0.0	0.005	7.3	LOS A	0.0	0.1	0.14	0.60	0.14	74.3
9	R2	All MCs	1 0.0	1 0.0	0.005	8.1	LOS A	0.0	0.1	0.14	0.60	0.14	73.8
Approach			6 0.0	6 0.0	0.005	7.9	LOS A	0.0	0.1	0.14	0.60	0.14	74.0
West: Murray Valley Highway													
10	L2	All MCs	1 0.0	1 0.0	0.043	8.3	LOS A	0.2	1.3	0.19	0.28	0.19	81.5
11	T1	All MCs	43 2.4	43 2.4	0.043	0.3	LOS A	0.2	1.3	0.19	0.28	0.19	92.3
12	R2	All MCs	24 34.8	24 34.8	0.043	8.9	LOS A	0.2	1.3	0.19	0.28	0.19	67.4
Approach			68 13.8	68 13.8	0.043	3.5	NA	0.2	1.3	0.19	0.28	0.19	81.5
All Vehicles			199 19.0	199 19.0	0.066	3.5	NA	0.2	1.3	0.08	0.28	0.08	82.6

Site Level of Service (LOS) Method: Delay (SIDRA). Site LOS Method is specified in the Parameter Settings dialog (Options tab).  
 Vehicle movement LOS values are based on average delay per movement.  
 Minor Road Approach LOS values are based on average delay for all vehicle movements.  
 NA (TWSC): Level of Service is not defined for major road approaches or the intersection as a whole for Two-Way Sign Control (HCM LOS rule).  
 Two-Way Sign Control Capacity Model: SIDRA Standard.  
 Delay Model: SIDRA Standard (Control Delay: Geometric Delay is included).  
 Queue Model: SIDRA queue estimation methods are used for Back of Queue and Queue at Start of Gap.  
 Gap-Acceptance Capacity Formula: SIDRA Standard (Akçelik M3D).  
 HV (%) values are calculated for All Movement Classes of All Heavy Vehicle Model Designation.  
 Arrival Flows used in performance calculations are adjusted to include any Initial Queued Demand and Upstream Capacity Constraint effects.

# MOVEMENT SUMMARY

Site: [3] 2052 BG-DEV AM (Development Peak 2) (Murray Valley Hwy/Roslynmead Rd/Bail Rd Intersection)

Output produced by SIDRA INTERSECTION Version: 10.0.5.217

New Site  
 Site Category: (None)  
 Give-Way (Two-Way)  
 Site Scenario: 1 | Local Volumes

Vehicle Movement Performance													
Mov ID	Turn	Mov Class	Demand Flows [ Total HV ]	Arrival Flows [ Total HV ]	Deg. Satn	Aver. Delay	Level of Service	95% Back Of Queue [ Veh. ]	Dist [ m ]	Prop. Qued	Eff. Stop Rate	Number of Cycles to Depart	Aver. Speed
			veh/h %	veh/h %	v/c	sec		veh	m				km/h
South: Roslynmead Road													
1	L2	All MCs	40 42.1	40 42.1	0.043	9.8	LOS A	0.2	1.6	0.31	0.63	0.31	59.6
2	T1	All MCs	4 50.0	4 50.0	0.043	10.3	LOS B	0.2	1.6	0.31	0.63	0.31	59.0
3	R2	All MCs	1 0.0	1 0.0	0.043	9.2	LOS A	0.2	1.6	0.31	0.63	0.31	72.0
Approach			45 41.9	45 41.9	0.043	9.8	LOS A	0.2	1.6	0.31	0.63	0.31	59.8
East: Murray Valley Highway													
4	L2	All MCs	4 0.0	4 0.0	0.100	8.1	LOS A	0.0	0.4	0.02	0.04	0.02	86.1
5	T1	All MCs	147 37.1	147 37.1	0.100	0.0	LOS A	0.0	0.4	0.02	0.04	0.02	98.3
6	R2	All MCs	4 50.0	4 50.0	0.100	9.2	LOS A	0.0	0.4	0.02	0.04	0.02	65.4
Approach			156 36.5	156 36.5	0.100	0.5	NA	0.0	0.4	0.02	0.04	0.02	96.6
North: Bail Road													
7	L2	All MCs	4 0.0	4 0.0	0.005	8.2	LOS A	0.0	0.1	0.26	0.59	0.26	73.3
8	T1	All MCs	1 0.0	1 0.0	0.005	8.0	LOS A	0.0	0.1	0.26	0.59	0.26	73.6
9	R2	All MCs	1 0.0	1 0.0	0.005	9.4	LOS A	0.0	0.1	0.26	0.59	0.26	73.1
Approach			6 0.0	6 0.0	0.005	8.4	LOS A	0.0	0.1	0.26	0.59	0.26	73.3
West: Murray Valley Highway													
10	L2	All MCs	2 0.0	2 0.0	0.093	8.7	LOS A	0.2	1.8	0.13	0.17	0.13	83.8
11	T1	All MCs	120 20.2	120 20.2	0.093	0.2	LOS A	0.2	1.8	0.13	0.17	0.13	95.3
12	R2	All MCs	24 39.1	24 39.1	0.093	9.4	LOS A	0.2	1.8	0.13	0.17	0.13	67.5
Approach			146 23.0	146 23.0	0.093	1.9	NA	0.2	1.8	0.13	0.17	0.13	89.1
All Vehicles			354 31.0	354 31.0	0.100	2.4	NA	0.2	1.8	0.11	0.18	0.11	86.3

Site Level of Service (LOS) Method: Delay (SIDRA). Site LOS Method is specified in the Parameter Settings dialog (Options tab).  
 Vehicle movement LOS values are based on average delay per movement.  
 Minor Road Approach LOS values are based on average delay for all vehicle movements.  
 NA (TWSC): Level of Service is not defined for major road approaches or the intersection as a whole for Two-Way Sign Control (HCM LOS rule).  
 Two-Way Sign Control Capacity Model: SIDRA Standard.  
 Delay Model: SIDRA Standard (Control Delay: Geometric Delay is included).  
 Queue Model: SIDRA queue estimation methods are used for Back of Queue and Queue at Start of Gap.  
 Gap-Acceptance Capacity Formula: SIDRA Standard (Akçelik M3D).  
 HV (%) values are calculated for All Movement Classes of All Heavy Vehicle Model Designation.  
 Arrival Flows used in performance calculations are adjusted to include any Initial Queued Demand and Upstream Capacity Constraint effects.

# MOVEMENT SUMMARY

Site: [4] 2052 BG-DEV PM (Network Peak) (Murray Valley Hwy/ Roslynmead Rd/Bail Rd Intersection)

Output produced by SIDRA INTERSECTION Version: 10.0.5.217

New Site  
 Site Category: (None)  
 Give-Way (Two-Way)  
 Site Scenario: 1 | Local Volumes

Vehicle Movement Performance													
Mov ID	Turn	Mov Class	Demand Flows	Arrival Flows	Deg. Satn	Aver. Delay	Level of Service	95% Back Of Queue	Prop. Qued	Eff. Stop Rate	Number of Cycles to Depart	Aver. Speed	
			[ Total HV ]	[ Total HV ]	v/c	sec		[ Veh. ]	[ Dist ]			km/h	
			veh/h	%	veh/h	%		veh	m				
South: Roslynmead Road													
1	L2	All MCs	25 25.0	25 25.0	0.034	9.9	LOS A	0.1	1.0	0.42	0.67	0.42	63.4
2	T1	All MCs	1 0.0	1 0.0	0.034	10.0	LOS A	0.1	1.0	0.42	0.67	0.42	71.1
3	R2	All MCs	4 0.0	4 0.0	0.034	11.7	LOS B	0.1	1.0	0.42	0.67	0.42	71.1
Approach			31 20.7	31 20.7	0.034	10.2	LOS B	0.1	1.0	0.42	0.67	0.42	64.6
East: Murray Valley Highway													
4	L2	All MCs	1 0.0	1 0.0	0.175	8.9	LOS A	0.1	0.5	0.02	0.02	0.02	87.0
5	T1	All MCs	300 15.8	300 15.8	0.175	0.0	LOS A	0.1	0.5	0.02	0.02	0.02	99.5
6	R2	All MCs	4 50.0	4 50.0	0.175	9.9	LOS A	0.1	0.5	0.02	0.02	0.02	65.9
Approach			305 16.2	305 16.2	0.175	0.2	NA	0.1	0.5	0.02	0.02	0.02	98.7
North: Bail Road													
7	L2	All MCs	7 0.0	7 0.0	0.009	8.7	LOS A	0.0	0.2	0.39	0.62	0.39	72.3
8	T1	All MCs	1 0.0	1 0.0	0.009	9.8	LOS A	0.0	0.2	0.39	0.62	0.39	72.6
9	R2	All MCs	1 0.0	1 0.0	0.009	11.7	LOS B	0.0	0.2	0.39	0.62	0.39	72.1
Approach			9 0.0	9 0.0	0.009	9.2	LOS A	0.0	0.2	0.39	0.62	0.39	72.4
West: Murray Valley Highway													
10	L2	All MCs	3 66.7	3 66.7	0.177	11.2	LOS B	0.2	1.9	0.09	0.11	0.09	61.4
11	T1	All MCs	267 19.7	267 19.7	0.177	0.2	LOS A	0.2	1.9	0.09	0.11	0.09	97.5
12	R2	All MCs	20 31.6	20 31.6	0.177	10.1	LOS B	0.2	1.9	0.09	0.11	0.09	71.3
Approach			291 21.0	291 21.0	0.177	1.0	NA	0.2	1.9	0.09	0.11	0.09	94.5
All Vehicles			636 18.4	636 18.4	0.177	1.2	NA	0.2	1.9	0.08	0.10	0.08	93.9

Site Level of Service (LOS) Method: Delay (SIDRA). Site LOS Method is specified in the Parameter Settings dialog (Options tab).  
 Vehicle movement LOS values are based on average delay per movement.  
 Minor Road Approach LOS values are based on average delay for all vehicle movements.  
 NA (TWSC): Level of Service is not defined for major road approaches or the intersection as a whole for Two-Way Sign Control (HCM LOS rule).  
 Two-Way Sign Control Capacity Model: SIDRA Standard.  
 Delay Model: SIDRA Standard (Control Delay: Geometric Delay is included).  
 Queue Model: SIDRA queue estimation methods are used for Back of Queue and Queue at Start of Gap.  
 Gap-Acceptance Capacity Formula: SIDRA Standard (Akçelik M3D).  
 HV (%) values are calculated for All Movement Classes of All Heavy Vehicle Model Designation.  
 Arrival Flows used in performance calculations are adjusted to include any Initial Queued Demand and Upstream Capacity Constraint effects.

# MOVEMENT SUMMARY

Site: [5] 2052 BG-DEV PM (Development Peak 1) (Murray Valley Hwy/Roslynmead Rd/Bail Rd Intersection)

Output produced by SIDRA INTERSECTION Version: 10.0.5.217

New Site  
 Site Category: (None)  
 Give-Way (Two-Way)  
 Site Scenario: 1 | Local Volumes

Vehicle Movement Performance															
Mov ID	Turn	Mov Class	Demand Flows		Arrival Flows		Deg. Satn	Aver. Delay	Level of Service	95% Back Of Queue		Prop. Qued	Eff. Stop Rate	Number of Cycles to Depart	Aver. Speed
			[ Total HV ]	[ Total HV ]	[ Total HV ]	[ Total HV ]	v/c	sec		[ Veh. ]	[ Dist ]				km/h
			veh/h	%	veh/h	%				veh	m				
South: Roslynmead Road															
1	L2	All MCs	32	26.7	32	26.7	0.098	9.5	LOS A	0.3	2.7	0.47	0.72	0.47	61.9
2	T1	All MCs	1	0.0	1	0.0	0.098	10.2	LOS B	0.3	2.7	0.47	0.72	0.47	69.9
3	R2	All MCs	37	0.0	37	0.0	0.098	12.0	LOS B	0.3	2.7	0.47	0.72	0.47	69.8
Approach			69	12.1	69	12.1	0.098	10.9	LOS B	0.3	2.7	0.47	0.72	0.47	66.0
East: Murray Valley Highway															
4	L2	All MCs	2	0.0	2	0.0	0.125	9.0	LOS A	0.1	0.5	0.04	0.05	0.04	86.2
5	T1	All MCs	214	12.3	214	12.3	0.125	0.1	LOS A	0.1	0.5	0.04	0.05	0.04	98.5
6	R2	All MCs	7	0.0	7	0.0	0.125	8.8	LOS A	0.1	0.5	0.04	0.05	0.04	86.2
Approach			223	11.8	223	11.8	0.125	0.4	NA	0.1	0.5	0.04	0.05	0.04	97.9
North: Bail Road															
7	L2	All MCs	12	0.0	12	0.0	0.029	9.0	LOS A	0.1	0.8	0.51	0.70	0.51	68.6
8	T1	All MCs	3	66.7	3	66.7	0.029	15.3	LOS C	0.1	0.8	0.51	0.70	0.51	53.5
9	R2	All MCs	3	66.7	3	66.7	0.029	19.1	LOS C	0.1	0.8	0.51	0.70	0.51	51.4
Approach			18	23.5	18	23.5	0.029	11.9	LOS B	0.1	0.8	0.51	0.70	0.51	61.9
West: Murray Valley Highway															
10	L2	All MCs	6	33.3	6	33.3	0.223	9.8	LOS A	0.3	2.9	0.10	0.12	0.10	71.1
11	T1	All MCs	327	19.6	327	19.6	0.223	0.2	LOS A	0.3	2.9	0.10	0.12	0.10	96.7
12	R2	All MCs	34	28.1	34	28.1	0.223	9.4	LOS A	0.3	2.9	0.10	0.12	0.10	72.2
Approach			367	20.6	367	20.6	0.223	1.2	NA	0.3	2.9	0.10	0.12	0.10	93.3
All Vehicles			678	16.9	678	16.9	0.223	2.2	NA	0.3	2.9	0.13	0.18	0.13	89.6

Site Level of Service (LOS) Method: Delay (SIDRA). Site LOS Method is specified in the Parameter Settings dialog (Options tab).  
 Vehicle movement LOS values are based on average delay per movement.  
 Minor Road Approach LOS values are based on average delay for all vehicle movements.  
 NA (TWSC): Level of Service is not defined for major road approaches or the intersection as a whole for Two-Way Sign Control (HCM LOS rule).  
 Two-Way Sign Control Capacity Model: SIDRA Standard.  
 Delay Model: SIDRA Standard (Control Delay: Geometric Delay is included).  
 Queue Model: SIDRA queue estimation methods are used for Back of Queue and Queue at Start of Gap.  
 Gap-Acceptance Capacity Formula: SIDRA Standard (Akçelik M3D).  
 HV (%) values are calculated for All Movement Classes of All Heavy Vehicle Model Designation.  
 Arrival Flows used in performance calculations are adjusted to include any Initial Queued Demand and Upstream Capacity Constraint effects.

# MOVEMENT SUMMARY

Site: [6] 2052 BG-DEV PM (Development Peak 2) (Murray Valley Hwy/Roslynmead Rd/Bail Rd Intersection)

Output produced by SIDRA INTERSECTION Version: 10.0.5.217

New Site  
 Site Category: (None)  
 Give-Way (Two-Way)  
 Site Scenario: 1 | Local Volumes

Vehicle Movement Performance													
Mov ID	Turn	Mov Class	Demand Flows	Arrival Flows	Deg. Satn	Aver. Delay	Level of Service	95% Back Of Queue	Prop. Qued	Eff. Stop Rate	Number of Cycles to Depart	Aver. Speed	
			[ Total HV ]	[ Total HV ]	v/c	sec		[ Veh. Dist ]				km/h	
			veh/h	%	veh/h	%		veh	m				
South: Roslynmead Road													
1	L2	All MCs	23 36.4	23 36.4	0.039	10.6	LOS B	0.1	1.2	0.46	0.70	0.46	59.9
2	T1	All MCs	1 0.0	1 0.0	0.039	10.0	LOS B	0.1	1.2	0.46	0.70	0.46	70.5
3	R2	All MCs	6 0.0	6 0.0	0.039	11.7	LOS B	0.1	1.2	0.46	0.70	0.46	70.5
Approach			31 27.6	31 27.6	0.039	10.8	LOS B	0.1	1.2	0.46	0.70	0.46	62.2
East: Murray Valley Highway													
4	L2	All MCs	2 0.0	2 0.0	0.188	7.9	LOS A	0.0	0.2	0.01	0.01	0.01	87.1
5	T1	All MCs	333 13.0	333 13.0	0.188	0.0	LOS A	0.0	0.2	0.01	0.01	0.01	99.6
6	R2	All MCs	2 0.0	2 0.0	0.188	7.6	LOS A	0.0	0.2	0.01	0.01	0.01	87.1
Approach			337 12.8	337 12.8	0.188	0.1	NA	0.0	0.2	0.01	0.01	0.01	99.4
North: Bail Road													
7	L2	All MCs	2 0.0	2 0.0	0.014	8.6	LOS A	0.0	0.4	0.53	0.69	0.53	68.1
8	T1	All MCs	3 66.7	3 66.7	0.014	15.2	LOS C	0.0	0.4	0.53	0.69	0.53	53.2
9	R2	All MCs	2 0.0	2 0.0	0.014	11.7	LOS B	0.0	0.4	0.53	0.69	0.53	68.0
Approach			7 28.6	7 28.6	0.014	12.3	LOS B	0.0	0.4	0.53	0.69	0.53	60.8
West: Murray Valley Highway													
10	L2	All MCs	2 0.0	2 0.0	0.163	9.6	LOS A	0.3	2.4	0.13	0.16	0.13	84.4
11	T1	All MCs	234 20.3	234 20.3	0.163	0.3	LOS A	0.3	2.4	0.13	0.16	0.13	96.1
12	R2	All MCs	27 23.1	27 23.1	0.163	9.9	LOS A	0.3	2.4	0.13	0.16	0.13	73.8
Approach			263 20.4	263 20.4	0.163	1.4	NA	0.3	2.4	0.13	0.16	0.13	93.1
All Vehicles			638 16.8	638 16.8	0.188	1.3	NA	0.3	2.4	0.08	0.11	0.08	93.4

Site Level of Service (LOS) Method: Delay (SIDRA). Site LOS Method is specified in the Parameter Settings dialog (Options tab).  
 Vehicle movement LOS values are based on average delay per movement.  
 Minor Road Approach LOS values are based on average delay for all vehicle movements.  
 NA (TWSC): Level of Service is not defined for major road approaches or the intersection as a whole for Two-Way Sign Control (HCM LOS rule).  
 Two-Way Sign Control Capacity Model: SIDRA Standard.  
 Delay Model: SIDRA Standard (Control Delay: Geometric Delay is included).  
 Queue Model: SIDRA queue estimation methods are used for Back of Queue and Queue at Start of Gap.  
 Gap-Acceptance Capacity Formula: SIDRA Standard (Akçelik M3D).  
 HV (%) values are calculated for All Movement Classes of All Heavy Vehicle Model Designation.  
 Arrival Flows used in performance calculations are adjusted to include any Initial Queued Demand and Upstream Capacity Constraint effects.

# SIGN CONTROL ANALYSIS

Site: [1] 2052 BG-DEV AM (Network Peak) (Murray Valley Hwy/ Roslynmead Rd/Bail Rd Intersection)

Output produced by SIDRA INTERSECTION Version: 10.0.5.217

New Site

Site Category: (None)

Give-Way (Two-Way)

Site Scenario: 1 | Local Volumes

Sign Control Basic Parameters				
Approach Control	Leg Geometry	App. Dist m	Prop Queued Upstr Signal	Extra Bunching %
South: Roslynmead Road				
Give-Way	Two Way	500.0	NA <sup>5</sup>	0.0 <sup>3</sup>
East: Murray Valley Highway				
Major Road	Two Way	500.0	NA <sup>5</sup>	0.0 <sup>3</sup>
North: Bail Road				
Give-Way	Two Way	500.0	NA <sup>5</sup>	0.0 <sup>3</sup>
West: Murray Valley Highway				
Major Road	Two Way	500.0	NA <sup>5</sup>	0.0 <sup>3</sup>

Two-Way Sign Control Capacity Model: SIDRA Standard.

Gap-Acceptance Capacity Formula: SIDRA Standard (Akçelik M3D).

<sup>3</sup> User-specified Extra Bunching

<sup>5</sup> Not Applicable (single Site analysis or unconnected Site in Network analysis).

Gap Acceptance Parameters												
Opposed Lane	Dest	Turn	Apply Calib	Opng Flow veh/h	Opng Flow pcu/h	In-Bunch Hdw sec	Prop. Bunched	Gap Acc Factor	Critical Gap (tc) [ Hdw Dist ] sec m	Follow-up Hdw (tf) sec	Ratio tf / tc	
South: Roslynmead Road												
1	East	R2	Y	581 <sup>14</sup>	633 <sup>14</sup>	1.03	0.062	1.00	5.00	131.5	3.20	0.64
1	North	T1	Y	577 <sup>14</sup>	628 <sup>14</sup>	1.05	0.043	1.00	4.50	119.0	2.70	0.60
1	West	L2	Y	212	239	1.80	0.026	1.23	4.93	137.0	2.71	0.55
East: Murray Valley Highway												
1	North	R2	Y	332 <sup>14</sup>	349 <sup>14</sup>	1.80	0.041	1.00	4.00	110.8	2.00	0.50
North: Bail Road												
1	South	T1	Y	577 <sup>14</sup>	628 <sup>14</sup>	1.05	0.043	1.33	6.00	158.4	3.60	0.60
1	East	L2	Y	331	348	1.80	0.040	1.00	4.00	111.1	2.20	0.55
1	West	R2	Y	608 <sup>14</sup>	666 <sup>14</sup>	0.96	0.061	1.25	6.25	158.5	4.00	0.64
West: Murray Valley Highway												
1	South	R2	Y	214 <sup>14</sup>	241 <sup>14</sup>	1.80	0.027	1.19	4.76	131.1	2.38	0.50

Two-Way Sign Control Capacity Model: SIDRA Standard.

Gap-Acceptance Capacity Formula: SIDRA Standard (Akçelik M3D).

Values in this table are adjusted for movement classes in the entry stream.

Use the Pedestrians and Priorities input dialogs to specify opposing pedestrian movements.

<sup>14</sup> Percentage of exiting flow included in opposing vehicle flow

Gap Acceptance Cycle Parameters (Lanes)					
Opposed Lane	Cycle Time sec	Blocked Time sec	Unblocked Time sec	Unblocked Time Ratio	Minimum Delay sec

South: Roslynmead Road					
1	19.06	4.61	14.45	0.758	1.2
East: Murray Valley Highway					
1	13.76	3.90	9.86	0.716	0.0
North: Bail Road					
1	16.38	8.94	7.44	0.454	5.5
West: Murray Valley Highway					
1	19.11	4.42	14.68	0.769	0.2

Two-Way Sign Control Capacity Model: SIDRA Standard.  
Gap-Acceptance Capacity Formula: SIDRA Standard (Akçelik M3D).

Gap Acceptance Cycle Parameters (Movements)								
To Approach	Turn	Lane No	Cycle Time sec	Blocked Time sec	Unblocked Time sec	Unblocked Time Ratio	Minimum Delay sec	
South: Roslynmead Road								
West	L2	1	19.48	4.49	14.98	0.769	1.0	
North	T1	1	12.12	5.88	6.24	0.515	2.8	
East	R2	1	13.49	6.92	6.57	0.487	3.6	
East: Murray Valley Highway								
North	R2	1	13.76	3.90	9.86	0.716	1.0	
North: Bail Road								
East	L2	1	13.79	3.80	9.99	0.725	1.0	
South	T1	1	16.48	9.79	6.69	0.406	6.0	
West	R2	1	17.60	10.87	6.73	0.382	7.3	
West: Murray Valley Highway								
South	R2	1	19.11	4.42	14.68	0.769	1.0	

Two-Way Sign Control Capacity Model: SIDRA Standard.  
Gap-Acceptance Capacity Formula: SIDRA Standard (Akçelik M3D).

# SIGN CONTROL ANALYSIS

Site: [2] 2052 BG-DEV AM (Development Peak 1) (Murray Valley Hwy/Roslynmead Rd/Bail Rd Intersection)

Output produced by SIDRA INTERSECTION Version: 10.0.5.217

New Site

Site Category: (None)

Give-Way (Two-Way)

Site Scenario: 1 | Local Volumes

Sign Control Basic Parameters				
Approach Control	Leg Geometry	App. Dist m	Prop Queued Upstr Signal	Extra Bunching %
South: Roslynmead Road				
Give-Way	Two Way	500.0	NA <sup>5</sup>	0.0 <sup>3</sup>
East: Murray Valley Highway				
Major Road	Two Way	500.0	NA <sup>5</sup>	0.0 <sup>3</sup>
North: Bail Road				
Give-Way	Two Way	500.0	NA <sup>5</sup>	0.0 <sup>3</sup>
West: Murray Valley Highway				
Major Road	Two Way	500.0	NA <sup>5</sup>	0.0 <sup>3</sup>

Two-Way Sign Control Capacity Model: SIDRA Standard.

Gap-Acceptance Capacity Formula: SIDRA Standard (Akçelik M3D).

<sup>3</sup> User-specified Extra Bunching

<sup>5</sup> Not Applicable (single Site analysis or unconnected Site in Network analysis).

Gap Acceptance Parameters												
Opposed Lane	Dest	Turn	Apply Calib	Opng Flow veh/h	Opng Flow pcu/h	In-Bunch Hdw sec	Prop. Bunched	Gap Acc Factor	Critical Gap (tc) [ Hdw Dist ] sec m	Follow-up Hdw (tf) sec	Ratio tf / tc	
South: Roslynmead Road												
1	East	R2	Y	167 <sup>14</sup>	183 <sup>14</sup>	0.97	0.015	1.00	5.00	115.4	3.20	0.64
1	North	T1	Y	163 <sup>14</sup>	178 <sup>14</sup>	1.02	0.011	1.00	4.50	106.1	2.70	0.60
1	West	L2	Y	75	86	1.80	0.009	1.38	5.50	152.8	3.02	0.55
East: Murray Valley Highway												
1	North	R2	Y	44 <sup>14</sup>	45 <sup>14</sup>	1.80	0.005	1.00	4.00	109.0	2.00	0.50
North: Bail Road												
1	South	T1	Y	181 <sup>14</sup>	196 <sup>14</sup>	1.07	0.012	1.00	4.50	90.1	2.70	0.60
1	East	L2	Y	43	44	1.80	0.004	1.00	4.00	111.1	2.20	0.55
1	West	R2	Y	153 <sup>14</sup>	172 <sup>14</sup>	0.87	0.013	1.00	5.00	113.0	3.20	0.64
West: Murray Valley Highway												
1	South	R2	Y	112 <sup>14</sup>	123 <sup>14</sup>	1.80	0.013	1.17	4.70	96.1	2.35	0.50

Two-Way Sign Control Capacity Model: SIDRA Standard.

Gap-Acceptance Capacity Formula: SIDRA Standard (Akçelik M3D).

Values in this table are adjusted for movement classes in the entry stream.

Use the Pedestrians and Priorities input dialogs to specify opposing pedestrian movements.

<sup>14</sup> Percentage of exiting flow included in opposing vehicle flow

Gap Acceptance Cycle Parameters (Lanes)					
Opposed Lane	Cycle Time sec	Blocked Time sec	Unblocked Time sec	Unblocked Time Ratio	Minimum Delay sec

South: Roslynmead Road					
1	40.45	4.25	36.20	0.895	0.5
East: Murray Valley Highway					
1	83.12	3.09	80.03	0.963	0.0
North: Bail Road					
1	64.80	3.29	61.50	0.949	0.3
West: Murray Valley Highway					
1	32.99	3.90	29.09	0.882	0.3

Two-Way Sign Control Capacity Model: SIDRA Standard.  
Gap-Acceptance Capacity Formula: SIDRA Standard (Akçelik M3D).

Gap Acceptance Cycle Parameters (Movements)								
To Approach	Turn	Lane No	Cycle Time sec	Blocked Time sec	Unblocked Time sec	Unblocked Time Ratio	Minimum Delay sec	
South: Roslynmead Road								
West	L2	1	46.39	4.35	42.04	0.906	0.4	
North	T1	1	24.41	3.70	20.71	0.849	0.6	
East	R2	1	24.74	4.11	20.63	0.834	0.7	
East: Murray Valley Highway								
North	R2	1	83.12	3.09	80.03	0.963	0.1	
North: Bail Road								
East	L2	1	85.06	2.99	82.07	0.965	0.1	
South	T1	1	22.59	3.76	18.83	0.834	0.6	
West	R2	1	25.97	4.06	21.91	0.844	0.7	
West: Murray Valley Highway								
South	R2	1	32.99	3.90	29.09	0.882	0.4	

Two-Way Sign Control Capacity Model: SIDRA Standard.  
Gap-Acceptance Capacity Formula: SIDRA Standard (Akçelik M3D).

# SIGN CONTROL ANALYSIS

Site: [3] 2052 BG-DEV AM (Development Peak 2) (Murray Valley Hwy/Roslynmead Rd/Bail Rd Intersection)

Output produced by SIDRA INTERSECTION Version: 10.0.5.217

New Site

Site Category: (None)

Give-Way (Two-Way)

Site Scenario: 1 | Local Volumes

Sign Control Basic Parameters				
Approach Control	Leg Geometry	App. Dist m	Prop Queued Upstr Signal	Extra Bunching %
South: Roslynmead Road				
Give-Way	Two Way	500.0	NA <sup>5</sup>	0.0 <sup>3</sup>
East: Murray Valley Highway				
Major Road	Two Way	500.0	NA <sup>5</sup>	0.0 <sup>3</sup>
North: Bail Road				
Give-Way	Two Way	500.0	NA <sup>5</sup>	0.0 <sup>3</sup>
West: Murray Valley Highway				
Major Road	Two Way	500.0	NA <sup>5</sup>	0.0 <sup>3</sup>

Two-Way Sign Control Capacity Model: SIDRA Standard.

Gap-Acceptance Capacity Formula: SIDRA Standard (Akçelik M3D).

<sup>3</sup> User-specified Extra Bunching

<sup>5</sup> Not Applicable (single Site analysis or unconnected Site in Network analysis).

Gap Acceptance Parameters												
Opposed Lane	Dest	Turn	Apply Calib	Opng Flow veh/h	Opng Flow pcu/h	In-Bunch Hdw sec	Prop. Bunched	Gap Acc Factor	Critical Gap (tc) [ Hdw Dist ] sec m	Follow-up Hdw (tf) sec	Ratio tf / tc	
South: Roslynmead Road												
1	East	R2	Y	303 <sup>14</sup>	348 <sup>14</sup>	0.91	0.028	1.00	5.00	126.1	3.20	0.64
1	North	T1	Y	300 <sup>14</sup>	345 <sup>14</sup>	0.94	0.019	1.25	5.62	143.0	3.38	0.60
1	West	L2	Y	147	175	1.80	0.019	1.21	4.84	134.5	2.66	0.55
East: Murray Valley Highway												
1	North	R2	Y	122 <sup>14</sup>	134 <sup>14</sup>	1.80	0.014	1.25	5.00	137.0	2.50	0.50
North: Bail Road												
1	South	T1	Y	301 <sup>14</sup>	346 <sup>14</sup>	0.94	0.020	1.00	4.50	113.8	2.70	0.60
1	East	L2	Y	120	132	1.80	0.014	1.00	4.00	111.1	2.20	0.55
1	West	R2	Y	341 <sup>14</sup>	396 <sup>14</sup>	0.79	0.028	1.00	5.00	114.9	3.20	0.64
West: Murray Valley Highway												
1	South	R2	Y	152 <sup>14</sup>	179 <sup>14</sup>	1.80	0.019	1.20	4.78	129.9	2.39	0.50

Two-Way Sign Control Capacity Model: SIDRA Standard.

Gap-Acceptance Capacity Formula: SIDRA Standard (Akçelik M3D).

Values in this table are adjusted for movement classes in the entry stream.

Use the Pedestrians and Priorities input dialogs to specify opposing pedestrian movements.

<sup>14</sup> Percentage of exiting flow included in opposing vehicle flow

Gap Acceptance Cycle Parameters (Lanes)					
Opposed Lane	Cycle Time sec	Blocked Time sec	Unblocked Time sec	Unblocked Time Ratio	Minimum Delay sec

South: Roslynmead Road					
1	23.73	4.30	19.43	0.819	0.8
East: Murray Valley Highway					
1	30.87	4.23	26.63	0.863	0.0
North: Bail Road					
1	25.17	3.71	21.46	0.853	0.7
West: Murray Valley Highway					
1	24.06	4.19	19.87	0.826	0.3

Two-Way Sign Control Capacity Model: SIDRA Standard.  
Gap-Acceptance Capacity Formula: SIDRA Standard (Akçelik M3D).

Gap Acceptance Cycle Parameters (Movements)								
To Approach	Turn	Lane No	Cycle Time sec	Blocked Time sec	Unblocked Time sec	Unblocked Time Ratio	Minimum Delay sec	
South: Roslynmead Road								
West	L2	1	24.61	4.12	20.49	0.833	0.7	
North	T1	1	17.26	5.90	11.36	0.658	2.1	
East	R2	1	16.21	4.92	11.29	0.697	1.5	
East: Murray Valley Highway								
North	R2	1	30.87	4.23	26.63	0.863	0.5	
North: Bail Road								
East	L2	1	30.10	3.18	26.91	0.894	0.3	
South	T1	1	15.33	4.34	10.99	0.717	1.2	
West	R2	1	15.31	5.17	10.14	0.662	1.8	
West: Murray Valley Highway								
South	R2	1	24.06	4.19	19.87	0.826	0.7	

Two-Way Sign Control Capacity Model: SIDRA Standard.  
Gap-Acceptance Capacity Formula: SIDRA Standard (Akçelik M3D).

# SIGN CONTROL ANALYSIS

Site: [4] 2052 BG-DEV PM (Network Peak) (Murray Valley Hwy/ Roslynmead Rd/Bail Rd Intersection)

Output produced by SIDRA INTERSECTION Version: 10.0.5.217

New Site

Site Category: (None)

Give-Way (Two-Way)

Site Scenario: 1 | Local Volumes

Sign Control Basic Parameters				
Approach Control	Leg Geometry	App. Dist m	Prop Queued Upstr Signal	Extra Bunching %
South: Roslynmead Road				
Give-Way	Two Way	500.0	NA <sup>5</sup>	0.0 <sup>3</sup>
East: Murray Valley Highway				
Major Road	Two Way	500.0	NA <sup>5</sup>	0.0 <sup>3</sup>
North: Bail Road				
Give-Way	Two Way	500.0	NA <sup>5</sup>	0.0 <sup>3</sup>
West: Murray Valley Highway				
Major Road	Two Way	500.0	NA <sup>5</sup>	0.0 <sup>3</sup>

Two-Way Sign Control Capacity Model: SIDRA Standard.

Gap-Acceptance Capacity Formula: SIDRA Standard (Akçelik M3D).

<sup>3</sup> User-specified Extra Bunching

<sup>5</sup> Not Applicable (single Site analysis or unconnected Site in Network analysis).

Gap Acceptance Parameters												
Opposed Lane	Dest	Turn	Apply Calib	Opng Flow veh/h	Opng Flow pcu/h	In-Bunch Hdwy sec	Prop. Bunched	Gap Acc Factor	Critical Gap (tc) [ Hdwy Dist ] sec m	Follow-up Hdwy (tf) sec	Ratio tf / tc	
South: Roslynmead Road												
1	East	R2	Y	601 <sup>14</sup>	655 <sup>14</sup>	0.89	0.055	1.00	5.00	132.7	3.20	0.64
1	North	T1	Y	595 <sup>14</sup>	651 <sup>14</sup>	0.91	0.038	1.00	4.50	120.3	2.70	0.60
1	West	L2	Y	300	324	1.80	0.037	1.12	4.50	125.0	2.48	0.55
East: Murray Valley Highway												
1	North	R2	Y	271 <sup>14</sup>	298 <sup>14</sup>	1.80	0.034	1.25	5.00	137.6	2.50	0.50
North: Bail Road												
1	South	T1	Y	594 <sup>14</sup>	649 <sup>14</sup>	0.91	0.038	1.00	4.50	120.6	2.70	0.60
1	East	L2	Y	267	294	1.80	0.033	1.00	4.00	111.1	2.20	0.55
1	West	R2	Y	619 <sup>14</sup>	677 <sup>14</sup>	0.85	0.054	1.00	5.00	129.7	3.20	0.64
West: Murray Valley Highway												
1	South	R2	Y	301 <sup>14</sup>	325 <sup>14</sup>	1.80	0.037	1.16	4.63	128.3	2.32	0.50

Two-Way Sign Control Capacity Model: SIDRA Standard.

Gap-Acceptance Capacity Formula: SIDRA Standard (Akçelik M3D).

Values in this table are adjusted for movement classes in the entry stream.

Use the Pedestrians and Priorities input dialogs to specify opposing pedestrian movements.

<sup>14</sup> Percentage of exiting flow included in opposing vehicle flow

Gap Acceptance Cycle Parameters (Lanes)					
Opposed Lane	Cycle Time sec	Blocked Time sec	Unblocked Time sec	Unblocked Time Ratio	Minimum Delay sec

South: Roslynmead Road					
1	14.92	4.78	10.14	0.680	1.6
East: Murray Valley Highway					
1	16.89	5.00	11.89	0.704	0.1
North: Bail Road					
1	14.94	4.28	10.66	0.713	1.4
West: Murray Valley Highway					
1	15.44	4.64	10.80	0.700	0.2

Two-Way Sign Control Capacity Model: SIDRA Standard.  
Gap-Acceptance Capacity Formula: SIDRA Standard (Akçelik M3D).

Gap Acceptance Cycle Parameters (Movements)								
To Approach	Turn	Lane No	Cycle Time sec	Blocked Time sec	Unblocked Time sec	Unblocked Time Ratio	Minimum Delay sec	
South: Roslynmead Road								
West	L2	1	15.27	4.35	10.92	0.715	1.2	
North	T1	1	12.14	5.98	6.16	0.507	2.9	
East	R2	1	13.51	7.04	6.48	0.479	3.7	
East: Murray Valley Highway								
North	R2	1	16.89	5.00	11.89	0.704	1.4	
North: Bail Road								
East	L2	1	15.54	3.62	11.92	0.767	0.8	
South	T1	1	12.14	5.97	6.17	0.508	2.9	
West	R2	1	13.54	7.22	6.32	0.467	3.8	
West: Murray Valley Highway								
South	R2	1	15.44	4.64	10.80	0.700	1.3	

Two-Way Sign Control Capacity Model: SIDRA Standard.  
Gap-Acceptance Capacity Formula: SIDRA Standard (Akçelik M3D).

# SIGN CONTROL ANALYSIS

Site: [5] 2052 BG-DEV PM (Development Peak 1) (Murray Valley Hwy/Roslynmead Rd/Bail Rd Intersection)

Output produced by SIDRA INTERSECTION Version: 10.0.5.217

New Site

Site Category: (None)

Give-Way (Two-Way)

Site Scenario: 1 | Local Volumes

Sign Control Basic Parameters				
Approach Control	Leg Geometry	App. Dist m	Prop Queued Upstr Signal	Extra Bunching %
South: Roslynmead Road				
Give-Way	Two Way	500.0	NA <sup>5</sup>	0.0 <sup>3</sup>
East: Murray Valley Highway				
Major Road	Two Way	500.0	NA <sup>5</sup>	0.0 <sup>3</sup>
North: Bail Road				
Give-Way	Two Way	500.0	NA <sup>5</sup>	0.0 <sup>3</sup>
West: Murray Valley Highway				
Major Road	Two Way	500.0	NA <sup>5</sup>	0.0 <sup>3</sup>

Two-Way Sign Control Capacity Model: SIDRA Standard.

Gap-Acceptance Capacity Formula: SIDRA Standard (Akçelik M3D).

<sup>3</sup> User-specified Extra Bunching

<sup>5</sup> Not Applicable (single Site analysis or unconnected Site in Network analysis).

Gap Acceptance Parameters												
Opposed Lane	Dest	Turn	Apply Calib	Opng Flow veh/h	Opng Flow pcu/h	In-Bunch Hdw sec	Prop. Bunched	Gap Acc Factor	Critical Gap (tc) [ Hdw Dist ] sec m	Follow-up Hdw (tf) sec	Ratio tf / tc	
South: Roslynmead Road												
1	East	R2	Y	598 <sup>14</sup>	649 <sup>14</sup>	1.02	0.063	1.00	5.00	128.3	3.20	0.64
1	North	T1	Y	589 <sup>14</sup>	641 <sup>14</sup>	1.08	0.045	1.00	4.50	116.7	2.70	0.60
1	West	L2	Y	214	227	1.80	0.025	1.13	4.53	125.9	2.49	0.55
East: Murray Valley Highway												
1	North	R2	Y	334 <sup>14</sup>	367 <sup>14</sup>	1.80	0.043	1.00	4.00	109.4	2.00	0.50
North: Bail Road												
1	South	T1	Y	587 <sup>14</sup>	638 <sup>14</sup>	1.07	0.045	1.33	6.00	156.5	3.60	0.60
1	East	L2	Y	327	359	1.80	0.042	1.00	4.00	111.1	2.20	0.55
1	West	R2	Y	618 <sup>14</sup>	673 <sup>14</sup>	0.99	0.063	1.33	6.67	167.1	4.27	0.64
West: Murray Valley Highway												
1	South	R2	Y	216 <sup>14</sup>	229 <sup>14</sup>	1.80	0.025	1.14	4.56	125.8	2.28	0.50

Two-Way Sign Control Capacity Model: SIDRA Standard.

Gap-Acceptance Capacity Formula: SIDRA Standard (Akçelik M3D).

Values in this table are adjusted for movement classes in the entry stream.

Use the Pedestrians and Priorities input dialogs to specify opposing pedestrian movements.

<sup>14</sup> Percentage of exiting flow included in opposing vehicle flow

Gap Acceptance Cycle Parameters (Lanes)					
Opposed Lane	Cycle Time sec	Blocked Time sec	Unblocked Time sec	Unblocked Time Ratio	Minimum Delay sec

South: Roslynmead Road					
1	16.28	5.65	10.63	0.653	2.4
East: Murray Valley Highway					
1	13.34	3.96	9.37	0.703	0.1
North: Bail Road					
1	15.07	6.45	8.62	0.572	3.3
West: Murray Valley Highway					
1	19.57	4.15	15.42	0.788	0.2

Two-Way Sign Control Capacity Model: SIDRA Standard.  
Gap-Acceptance Capacity Formula: SIDRA Standard (Akçelik M3D).

Gap Acceptance Cycle Parameters (Movements)								
To Approach	Turn	Lane No	Cycle Time sec	Blocked Time sec	Unblocked Time sec	Unblocked Time Ratio	Minimum Delay sec	
South: Roslynmead Road								
West	L2	1	19.67	3.99	15.68	0.797	0.8	
North	T1	1	12.09	5.98	6.11	0.506	2.9	
East	R2	1	13.49	7.06	6.43	0.477	3.7	
East: Murray Valley Highway								
North	R2	1	13.34	3.96	9.37	0.703	1.1	
North: Bail Road								
East	L2	1	13.51	3.84	9.67	0.716	1.0	
South	T1	1	16.54	9.96	6.59	0.398	6.2	
West	R2	1	19.33	12.53	6.80	0.352	8.6	
West: Murray Valley Highway								
South	R2	1	19.57	4.15	15.42	0.788	0.8	

Two-Way Sign Control Capacity Model: SIDRA Standard.  
Gap-Acceptance Capacity Formula: SIDRA Standard (Akçelik M3D).

# SIGN CONTROL ANALYSIS

Site: [6] 2052 BG-DEV PM (Development Peak 2) (Murray Valley Hwy/Roslynmead Rd/Bail Rd Intersection)

Output produced by SIDRA INTERSECTION Version: 10.0.5.217

New Site

Site Category: (None)

Give-Way (Two-Way)

Site Scenario: 1 | Local Volumes

Sign Control Basic Parameters				
Approach Control	Leg Geometry	App. Dist m	Prop Queued Upstr Signal	Extra Bunching %
South: Roslynmead Road				
Give-Way	Two Way	500.0	NA <sup>5</sup>	0.0 <sup>3</sup>
East: Murray Valley Highway				
Major Road	Two Way	500.0	NA <sup>5</sup>	0.0 <sup>3</sup>
North: Bail Road				
Give-Way	Two Way	500.0	NA <sup>5</sup>	0.0 <sup>3</sup>
West: Murray Valley Highway				
Major Road	Two Way	500.0	NA <sup>5</sup>	0.0 <sup>3</sup>

Two-Way Sign Control Capacity Model: SIDRA Standard.

Gap-Acceptance Capacity Formula: SIDRA Standard (Akçelik M3D).

<sup>3</sup> User-specified Extra Bunching

<sup>5</sup> Not Applicable (single Site analysis or unconnected Site in Network analysis).

Gap Acceptance Parameters												
Opposed Lane	Dest	Turn	Apply Calib	Opng Flow veh/h	Opng Flow pcu/h	In-Bunch Hdw sec	Prop. Bunched	Gap Acc Factor	Critical Gap (tc) [ Hdw Dist ] sec m	Follow-up Hdw (tf) sec	Ratio tf / tc	
South: Roslynmead Road												
1	East	R2	Y	602 <sup>14</sup>	652 <sup>14</sup>	0.95	0.059	1.00	5.00	132.3	3.20	0.64
1	North	T1	Y	599 <sup>14</sup>	647 <sup>14</sup>	0.97	0.041	1.00	4.50	119.5	2.70	0.60
1	West	L2	Y	333	354	1.80	0.041	1.18	4.73	131.3	2.60	0.55
East: Murray Valley Highway												
1	North	R2	Y	236 <sup>14</sup>	259 <sup>14</sup>	1.80	0.029	1.00	4.00	110.3	2.00	0.50
North: Bail Road												
1	South	T1	Y	599 <sup>14</sup>	647 <sup>14</sup>	0.97	0.041	1.33	6.00	159.4	3.60	0.60
1	East	L2	Y	234	257	1.80	0.029	1.00	4.00	111.1	2.20	0.55
1	West	R2	Y	621 <sup>14</sup>	674 <sup>14</sup>	0.91	0.058	1.00	5.00	129.1	3.20	0.64
West: Murray Valley Highway												
1	South	R2	Y	335 <sup>14</sup>	356 <sup>14</sup>	1.80	0.042	1.12	4.46	123.3	2.23	0.50

Two-Way Sign Control Capacity Model: SIDRA Standard.

Gap-Acceptance Capacity Formula: SIDRA Standard (Akçelik M3D).

Values in this table are adjusted for movement classes in the entry stream.

Use the Pedestrians and Priorities input dialogs to specify opposing pedestrian movements.

<sup>14</sup> Percentage of exiting flow included in opposing vehicle flow

Gap Acceptance Cycle Parameters (Lanes)					
Opposed Lane	Cycle Time sec	Blocked Time sec	Unblocked Time sec	Unblocked Time Ratio	Minimum Delay sec

South: Roslynmead Road					
1	14.46	5.31	9.15	0.633	2.0
East: Murray Valley Highway					
1	17.05	3.62	13.43	0.788	0.0
North: Bail Road					
1	15.88	7.35	8.52	0.537	4.0
West: Murray Valley Highway					
1	14.33	4.55	9.78	0.682	0.4

Two-Way Sign Control Capacity Model: SIDRA Standard.  
Gap-Acceptance Capacity Formula: SIDRA Standard (Akçelik M3D).

Gap Acceptance Cycle Parameters (Movements)								
To Approach	Turn	Lane No	Cycle Time sec	Blocked Time sec	Unblocked Time sec	Unblocked Time Ratio	Minimum Delay sec	
South: Roslynmead Road								
West	L2	1	14.83	4.80	10.02	0.676	1.6	
North	T1	1	12.12	5.99	6.13	0.506	2.9	
East	R2	1	13.50	7.05	6.46	0.478	3.7	
East: Murray Valley Highway								
North	R2	1	17.05	3.62	13.43	0.788	0.7	
North: Bail Road								
East	L2	1	17.16	3.51	13.65	0.795	0.7	
South	T1	1	16.58	10.00	6.58	0.397	6.2	
West	R2	1	13.53	7.22	6.31	0.466	3.8	
West: Murray Valley Highway								
South	R2	1	14.33	4.55	9.78	0.682	1.4	

Two-Way Sign Control Capacity Model: SIDRA Standard.  
Gap-Acceptance Capacity Formula: SIDRA Standard (Akçelik M3D).

## Appendix G Turn warrant assessment

**WARRANTS FOR TURN TREATMENTS**

**PROJECT: 25E-0010 Poultry Farm - Torrumbarry**

**TITLE: 2052 PEAK HOUR TRAFFIC VOLUMES (NETWORK PEAK)**



**INTERSECTION DETAILS**

Major Road		Murray Valley Highway
Side Road		Roslynmead Road
Splitter Island on Major Road	Yes or No	No
Design Domain	NDD or EDD	NDD
Major Road Design Speed	(km/h)	More than/equal to 100

TRAFFIC VOLUMES (Vehicles/Hour)		BG		BG+DEV	
		AM	PM	AM	PM
Major Road approaching through traffic flow	$Q_{T1}$	311	253	314	256
Major Road opposing through traffic flow	$Q_{T2}$	200	287	203	290
Right turn traffic flow	$Q_R$	22	13	29	19
Left turn traffic flow	$Q_L$	2	0	2	0
Major Road traffic volume for right turn	$Q_M$	513	540	519	546
Major Road traffic volume for left turn	$Q_M$	200	287	203	290

Turn Warrant Graph (as adapted from Figure 3.25 Austroads Guide to Traffic Management Part 6 2020)

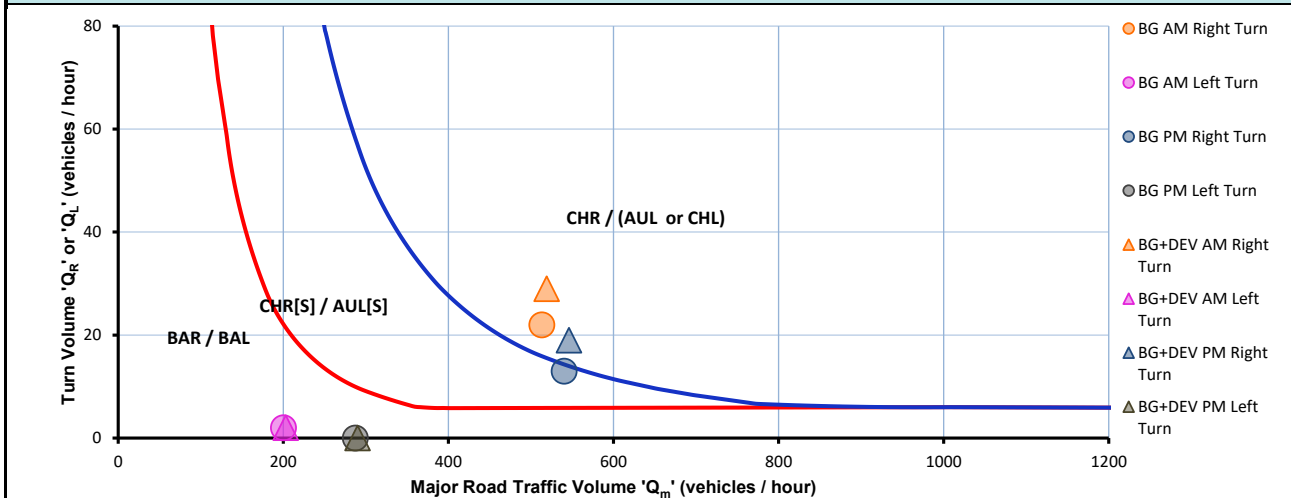
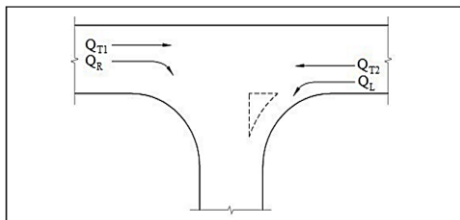

Figure 4A-A 4 - Calculation of the major road traffic volume parameter 'Q<sub>m</sub>'



Road Type	Turn Type	Splitter Island	$Q_m$ (veh/h)
2 Lane	Right	No	$= Q_{T1} + Q_{T2} + Q_L$
		Yes	$= Q_{T1} + Q_{T2}$
2 Way	Left	Yes/No	$= Q_{T2}$

**RESULTS:**

		BG	
		Right turn treatment	Left turn treatment
AM		CHR	BAL
PM		CHR[S]	BAL
		BG+DEV	
		Right turn treatment	Left turn treatment
AM		CHR	BAL
PM		CHR	BAL

**NOTES:**

**WARRANTS FOR TURN TREATMENTS**

**PROJECT: 25E-0010 Poultry Farm - Torrumbarry**

**TITLE: 2052 PEAK HOUR TRAFFIC VOLUMES (Development Peak 1)**



**INTERSECTION DETAILS**

Major Road		Murray Valley Highway
Side Road		Roslynmead Road
Splitter Island on Major Road	Yes or No	No
Design Domain	NDD or EDD	NDD
Major Road Design Speed	(km/h)	More than/equal to 100

TRAFFIC VOLUMES (Vehicles/Hour)		BG		BG+DEV	
		AM	PM	AM	PM
Major Road approaching through traffic flow	$Q_{T1}$	40	282	41	317
Major Road opposing through traffic flow	$Q_{T2}$	38	207	71	210
Right turn traffic flow	$Q_R$	9	27	24	33
Left turn traffic flow	$Q_L$	0	2	35	2
Major Road traffic volume for right turn	$Q_M$	78	491	147	529
Major Road traffic volume for left turn	$Q_M$	38	207	71	210

Turn Warrant Graph (as adapted from Figure 3.25 Austroads Guide to Traffic Management Part 6 2020)

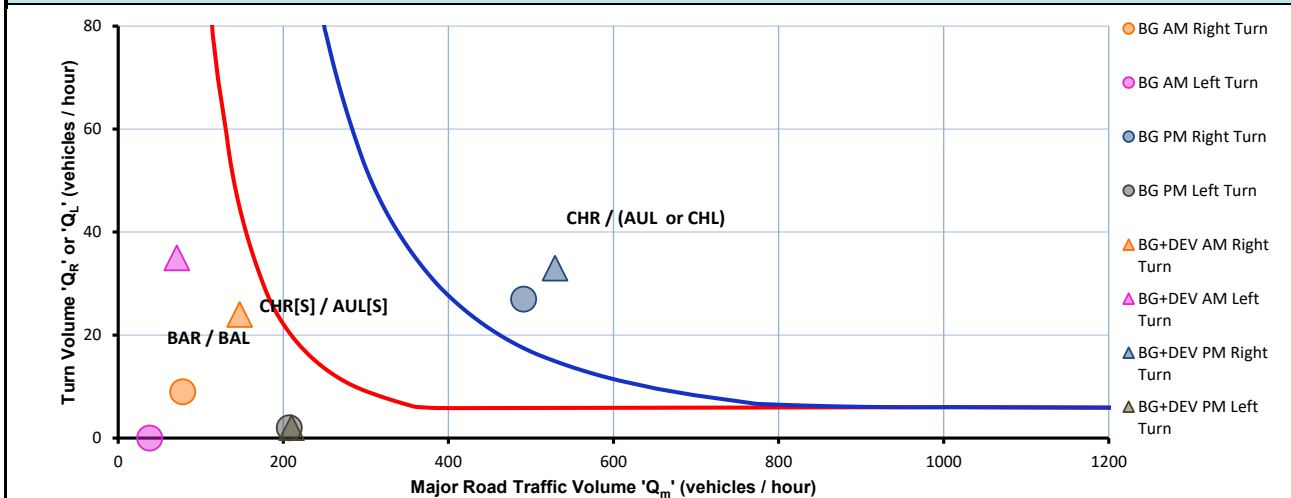
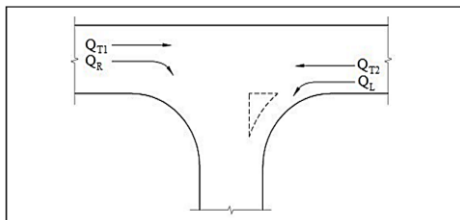

Figure 4A-A 4 - Calculation of the major road traffic volume parameter 'Q<sub>m</sub>'



Road Type	Turn Type	Splitter Island	Q <sub>m</sub> (veh/h)
2 Lane	Right	No	= $Q_{T1} + Q_{T2} + Q_L$
		Yes	= $Q_{T1} + Q_{T2}$
2 Way	Left	Yes/No	= $Q_{T2}$

**RESULTS:**

		BG	
		Right turn treatment	Left turn treatment
AM		BAR	BAL
PM		CHR	BAL
		BG+DEV	
		Right turn treatment	Left turn treatment
AM		BAR	BAL
PM		CHR	BAL

**NOTES:**

**WARRANTS FOR TURN TREATMENTS**

**PROJECT: 25E-0010 Poultry Farm - Torrumbarry**

**TITLE: 2052 PEAK HOUR TRAFFIC VOLUMES (Development Peak 2)**



**INTERSECTION DETAILS**

Major Road		Murray Valley Highway
Side Road		Roslynmead Road
Splitter Island on Major Road	Yes or No	No
Design Domain	NDD or EDD	NDD
Major Road Design Speed	(km/h)	More than/equal to 100

TRAFFIC VOLUMES (Vehicles/Hour)		BG		BG+DEV	
		AM	PM	AM	PM
Major Road approaching through traffic flow	$Q_{T1}$	113	207	116	224
Major Road opposing through traffic flow	$Q_{T2}$	127	315	144	318
Right turn traffic flow	$Q_R$	16	20	24	26
Left turn traffic flow	$Q_L$	0	2	4	2
Major Road traffic volume for right turn	$Q_M$	240	524	264	544
Major Road traffic volume for left turn	$Q_M$	127	315	144	318

Turn Warrant Graph (as adapted from Figure 3.25 Austroads Guide to Traffic Management Part 6 2020)

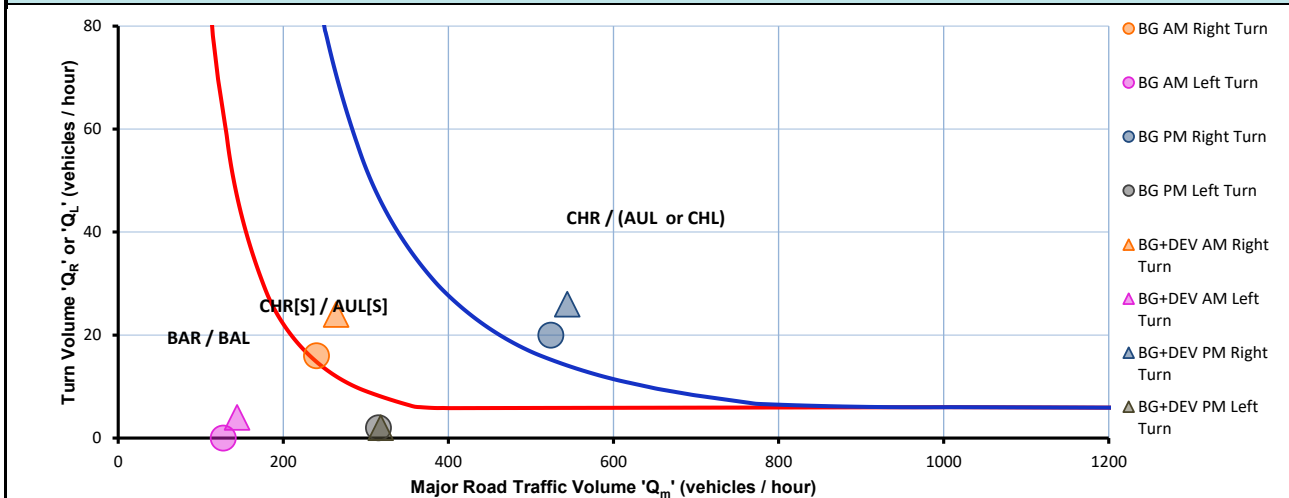
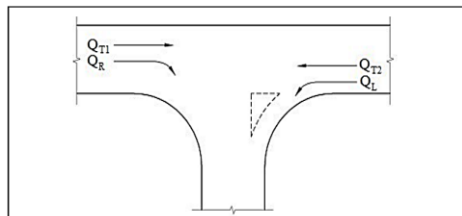

Figure 4A-A 4 - Calculation of the major road traffic volume parameter 'Q<sub>m</sub>'



Road Type	Turn Type	Splitter Island	$Q_m$ (veh/h)
2 Lane	Right	No	$= Q_{T1} + Q_{T2} + Q_L$
		Yes	$= Q_{T1} + Q_{T2}$
2 Way	Left	Yes/No	$= Q_{T2}$

**RESULTS:**

		BG	
		Right turn treatment	Left turn treatment
AM		CHR[S]	BAL
PM		CHR	BAL
		BG+DEV	
		Right turn treatment	Left turn treatment
AM		CHR[S]	BAL
PM		CHR	BAL

**NOTES:**

**WARRANTS FOR TURN TREATMENTS**

**PROJECT: 25E-0010 Poultry Farm - Torrumbarry**

**TITLE: 2052 PEAK HOUR TRAFFIC VOLUMES (Network Peak)**



**INTERSECTION DETAILS**

Major Road		Murray Valley Highway
Side Road		Heppell Road
Splitter Island on Major Road	Yes or No	No
Design Domain	NDD or EDD	NDD
Major Road Design Speed	(km/h)	More than/equal to 100

TRAFFIC VOLUMES (Vehicles/Hour)		BG		BG+DEV	
		AM	PM	AM	PM
Major Road approaching through traffic flow	$Q_{T1}$	224	300	230	305
Major Road opposing through traffic flow	$Q_{T2}$	333	267	338	271
Right turn traffic flow	$Q_R$	1	1	5	5
Left turn traffic flow	$Q_L$	1	1	2	2
Major Road traffic volume for right turn	$Q_M$	558	568	570	578
Major Road traffic volume for left turn	$Q_M$	333	267	338	271

Turn Warrant Graph (as adapted from Figure 3.25 Austroads Guide to Traffic Management Part 6 2020)

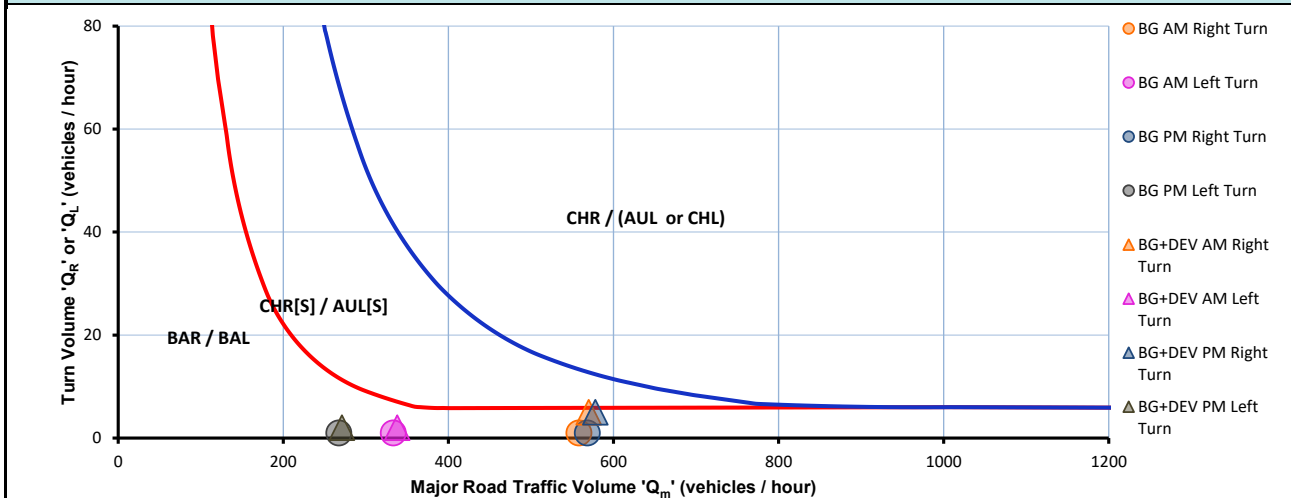
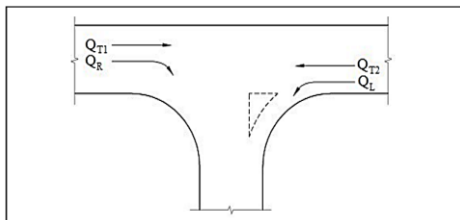

Figure 4A-A 4 - Calculation of the major road traffic volume parameter 'Q<sub>m</sub>'



Road Type	Turn Type	Splitter Island	Q <sub>m</sub> (veh/h)
2 Lane	Right	No	= $Q_{T1} + Q_{T2} + Q_L$
		Yes	= $Q_{T1} + Q_{T2}$
2 Way	Left	Yes/No	= $Q_{T2}$

**RESULTS:**

		BG	
		Right turn treatment	Left turn treatment
AM		BAR	BAL
PM		BAR	BAL
		BG+DEV	
		Right turn treatment	Left turn treatment
AM		BAR	BAL
PM		BAR	BAL

**NOTES:**

**WARRANTS FOR TURN TREATMENTS**

**PROJECT: 25E-0010 Poultry Farm - Torrumbarry**

**TITLE: 2052 PEAK HOUR TRAFFIC VOLUMES (Development Peak 1)**



**INTERSECTION DETAILS**

Major Road		Murray Valley Highway
Side Road		Heppell Road
Splitter Island on Major Road	Yes or No	No
Design Domain	NDD or EDD	NDD
Major Road Design Speed	(km/h)	More than/equal to 100

TRAFFIC VOLUMES (Vehicles/Hour)		BG		BG+DEV	
		AM	PM	AM	PM
Major Road approaching through traffic flow	$Q_{T1}$	40	218	43	231
Major Road opposing through traffic flow	$Q_{T2}$	49	309	60	313
Right turn traffic flow	$Q_R$	1	1	37	5
Left turn traffic flow	$Q_L$	1	1	10	2
Major Road traffic volume for right turn	$Q_M$	90	528	113	546
Major Road traffic volume for left turn	$Q_M$	49	309	60	313

Turn Warrant Graph (as adapted from Figure 3.25 Austroads Guide to Traffic Management Part 6 2020)

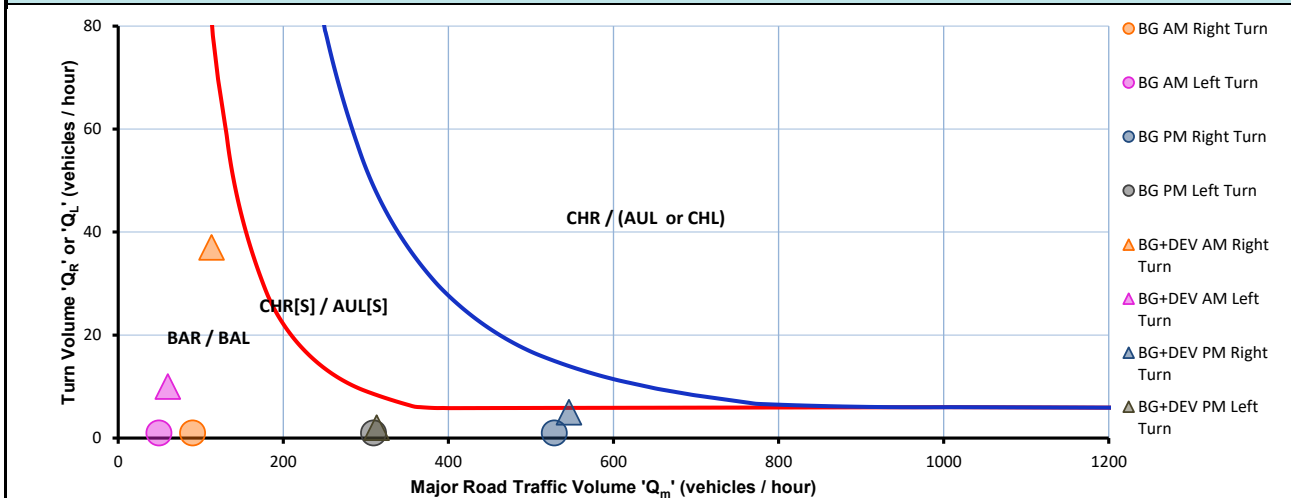
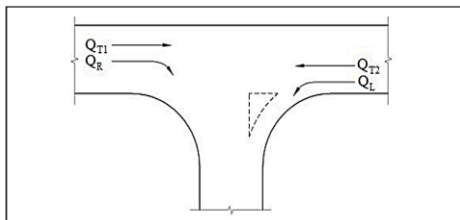

Figure 4A-A 4 - Calculation of the major road traffic volume parameter 'Q<sub>m</sub>'



Road Type	Turn Type	Splitter Island	Q <sub>m</sub> (veh/h)
2 Lane	Right	No	= $Q_{T1} + Q_{T2} + Q_L$
		Yes	= $Q_{T1} + Q_{T2}$
2 Way	Left	Yes/No	= $Q_{T2}$

**RESULTS:**

		BG	
		Right turn treatment	Left turn treatment
AM		BAR	BAL
PM		BAR	BAL
		BG+DEV	
		Right turn treatment	Left turn treatment
AM		BAR	BAL
PM		BAR	BAL

**NOTES:**

**WARRANTS FOR TURN TREATMENTS**

PROJECT: 25E-0010 Poultry Farm - Torrumbarry

TITLE: 2052 PEAK HOUR TRAFFIC VOLUMES (Development Peak 2)



**INTERSECTION DETAILS**

Major Road		Murray Valley Highway
Side Road		Heppell Road
Splitter Island on Major Road	Yes or No	No
Design Domain	NDD or EDD	NDD
Major Road Design Speed	(km/h)	More than/equal to 100

TRAFFIC VOLUMES (Vehicles/Hour)		BG		BG+DEV	
		AM	PM	AM	PM
Major Road approaching through traffic flow	$Q_{T1}$	153	331	174	337
Major Road opposing through traffic flow	$Q_{T2}$	129	227	135	245
Right turn traffic flow	$Q_R$	1	1	5	5
Left turn traffic flow	$Q_L$	1	1	2	2
Major Road traffic volume for right turn	$Q_M$	283	559	311	584
Major Road traffic volume for left turn	$Q_M$	129	227	135	245

Turn Warrant Graph (as adapted from Figure 3.25 Austroads Guide to Traffic Management Part 6 2020)

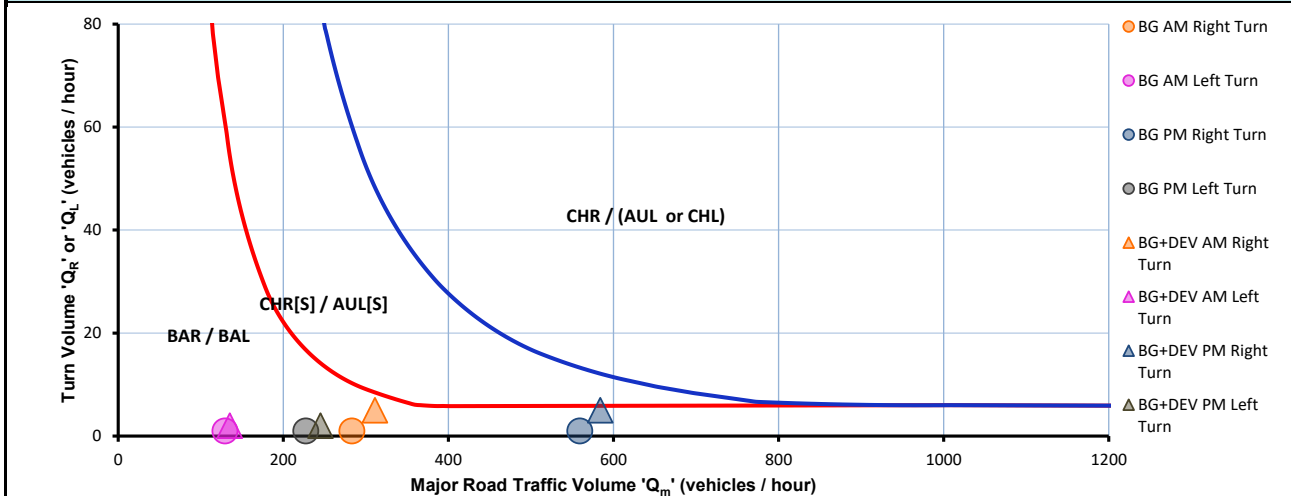
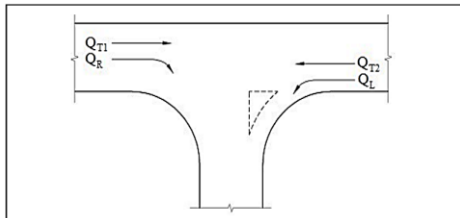

Figure 4A-A 4 - Calculation of the major road traffic volume parameter 'Q<sub>M</sub>'



Road Type	Turn Type	Splitter Island	$Q_M$ (veh/h)
2 Lane	Right	No	$= Q_{T1} + Q_{T2} + Q_L$
		Yes	$= Q_{T1} + Q_{T2}$
2 Way	Left	Yes/No	$= Q_{T2}$

**RESULTS:**

		BG	
		Right turn treatment	Left turn treatment
AM		BAR	BAL
PM		BAR	BAL
		BG+DEV	
		Right turn treatment	Left turn treatment
AM		BAR	BAL
PM		BAR	BAL

**NOTES:**

**WARRANTS FOR TURN TREATMENTS**

**PROJECT: 25E-0010 Poultry Farm - Torrumbarry**

**TITLE: 2052 PEAK HOUR TRAFFIC VOLUMES (Network Peak)**



**INTERSECTION DETAILS**

Major Road		Murray Valley Highway
Side Road		Davis Road
Splitter Island on Major Road	Yes or No	No
Design Domain	NDD or EDD	NDD
Major Road Design Speed	(km/h)	More than/equal to 100

TRAFFIC VOLUMES (Vehicles/Hour)		BG		BG+DEV	
		AM	PM	AM	PM
Major Road approaching through traffic flow	$Q_{T1}$	302	260	302	260
Major Road opposing through traffic flow	$Q_{T2}$	204	282	204	282
Right turn traffic flow	$Q_R$	2	0	2	0
Left turn traffic flow	$Q_L$	7	0	13	5
Major Road traffic volume for right turn	$Q_M$	513	542	519	547
Major Road traffic volume for left turn	$Q_M$	204	282	204	282

Turn Warrant Graph (as adapted from Figure 3.25 Austroads Guide to Traffic Management Part 6 2020)

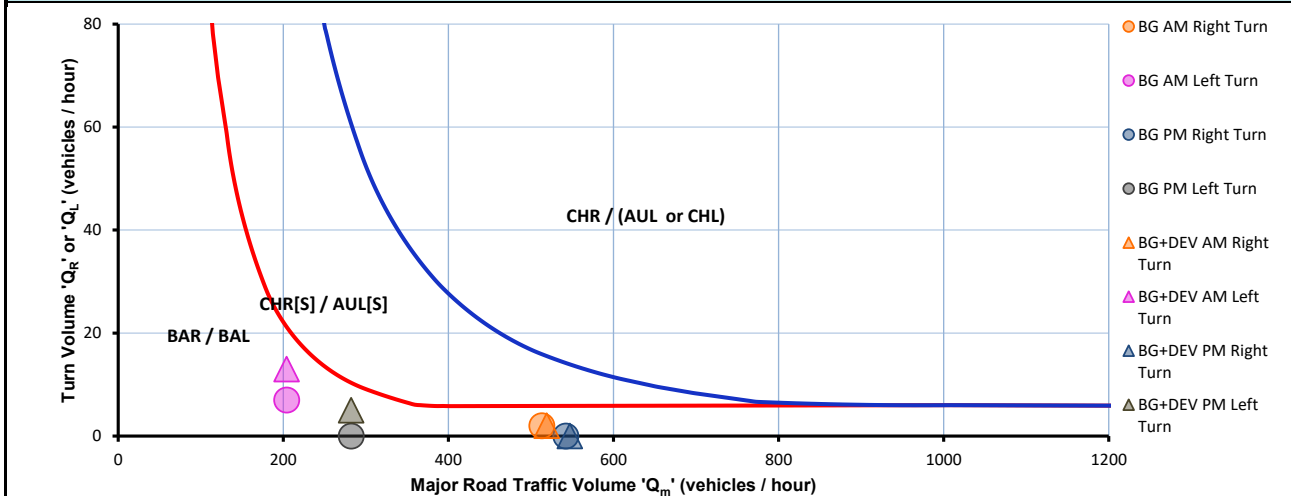
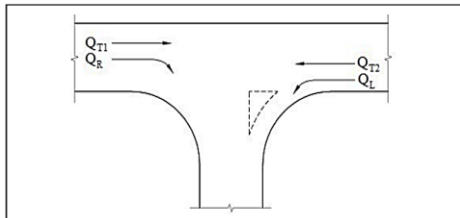

Figure 4A-A 4 - Calculation of the major road traffic volume parameter 'Q<sub>m</sub>'



Road Type	Turn Type	Splitter Island	$Q_m$ (veh/h)
2 Lane	Right	No	$= Q_{T1} + Q_{T2} + Q_L$
		Yes	$= Q_{T1} + Q_{T2}$
2 Way	Left	Yes/No	$= Q_{T2}$

**RESULTS:**

		BG	
		Right turn treatment	Left turn treatment
AM		BAR	BAL
PM		BAR	BAL
		BG+DEV	
		Right turn treatment	Left turn treatment
AM		BAR	BAL
PM		BAR	BAL

**NOTES:**

**WARRANTS FOR TURN TREATMENTS**

**PROJECT: 25E-0010 Poultry Farm - Torrumbarry**

**TITLE: 2052 PEAK HOUR TRAFFIC VOLUMES (Development Peak 1)**



**INTERSECTION DETAILS**

Major Road		Murray Valley Highway
Side Road		Davis Road
Splitter Island on Major Road	Yes or No	No
Design Domain	NDD or EDD	NDD
Major Road Design Speed	(km/h)	More than/equal to 100

TRAFFIC VOLUMES (Vehicles/Hour)		BG		BG+DEV	
		AM	PM	AM	PM
Major Road approaching through traffic flow	$Q_{T1}$	44	255	61	255
Major Road opposing through traffic flow	$Q_{T2}$	38	227	38	243
Right turn traffic flow	$Q_R$	2	0	2	0
Left turn traffic flow	$Q_L$	7	4	10	9
Major Road traffic volume for right turn	$Q_M$	89	486	109	507
Major Road traffic volume for left turn	$Q_M$	38	227	38	243

Turn Warrant Graph (as adapted from Figure 3.25 Austroads Guide to Traffic Management Part 6 2020)

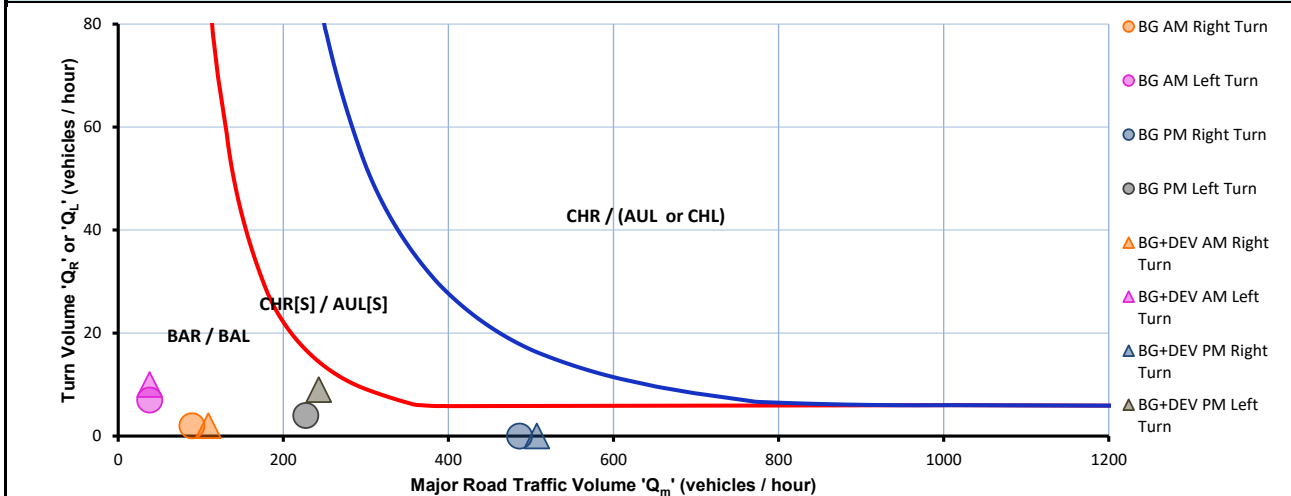
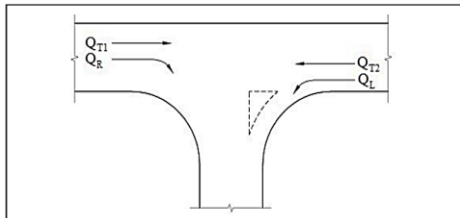

Figure 4A-A 4 - Calculation of the major road traffic volume parameter 'Q<sub>M</sub>'



Road Type	Turn Type	Splitter Island	$Q_M$ (veh/h)
2 Lane	Right	No	$= Q_{T1} + Q_{T2} + Q_L$
		Yes	$= Q_{T1} + Q_{T2}$
2 Way	Left	Yes/No	$= Q_{T2}$

**RESULTS:**

		BG	
		Right turn treatment	Left turn treatment
AM		BAR	BAL
PM		BAR	BAL
		BG+DEV	
		Right turn treatment	Left turn treatment
AM		BAR	BAL
PM		BAR	BAL

**NOTES:**

**WARRANTS FOR TURN TREATMENTS**

**PROJECT: 25E-0010 Poultry Farm - Torrumbarry**

**TITLE: 2052 PEAK HOUR TRAFFIC VOLUMES (Development Peak 2)**



**INTERSECTION DETAILS**

Major Road		Murray Valley Highway
Side Road		Davis Road
Splitter Island on Major Road	Yes or No	No
Design Domain	NDD or EDD	NDD
Major Road Design Speed	(km/h)	More than/equal to 100

TRAFFIC VOLUMES (Vehicles/Hour)		BG		BG+DEV	
		AM	PM	AM	PM
Major Road approaching through traffic flow	$Q_{T1}$	102	218	103	218
Major Road opposing through traffic flow	$Q_{T2}$	120	275	120	276
Right turn traffic flow	$Q_R$	2	0	6	0
Left turn traffic flow	$Q_L$	9	2	29	7
Major Road traffic volume for right turn	$Q_M$	231	495	252	501
Major Road traffic volume for left turn	$Q_M$	120	275	120	276

Turn Warrant Graph (as adapted from Figure 3.25 Austroads Guide to Traffic Management Part 6 2020)

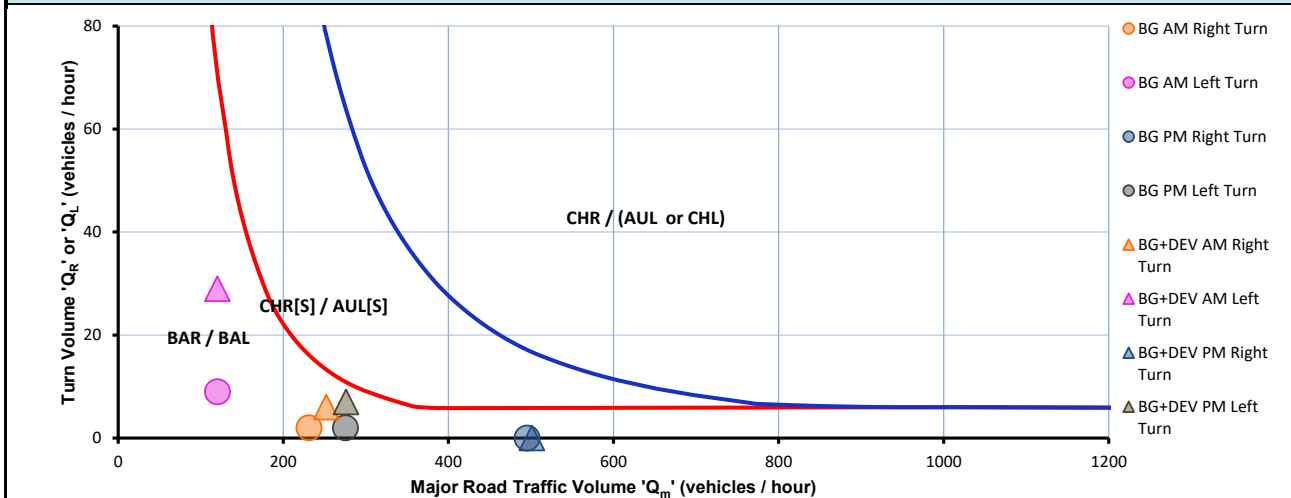
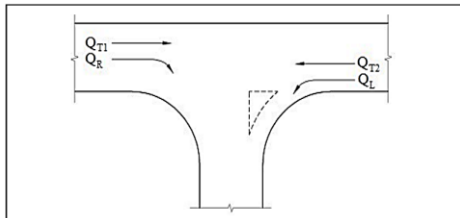

Figure 4A-A 4 - Calculation of the major road traffic volume parameter 'Q<sub>m</sub>'



Road Type	Turn Type	Splitter Island	Q <sub>m</sub> (veh/h)
2 Lane	Right	No	= $Q_{T1} + Q_{T2} + Q_L$
		Yes	= $Q_{T1} + Q_{T2}$
2 Way	Left	Yes/No	= $Q_{T2}$

**RESULTS:**

		BG	
		Right turn treatment	Left turn treatment
AM		BAR	BAL
PM		BAR	BAL
		BG+DEV	
		Right turn treatment	Left turn treatment
AM		BAR	BAL
PM		BAR	BAL

**NOTES:**

**WARRANTS FOR TURN TREATMENTS**

**PROJECT: 25E-0010 Poultry Farm - Torrumbarry**

**TITLE: 2052 PEAK HOUR TRAFFIC VOLUMES (Network Peak)**



**INTERSECTION DETAILS**

Major Road		Roslynmead Road
Side Road		Chrystal Road
Splitter Island on Major Road	Yes or No	No
Design Domain	NDD or EDD	NDD
Major Road Design Speed	(km/h)	More than/equal to 100

TRAFFIC VOLUMES (Vehicles/Hour)			BG		BG+DEV	
			AM	PM	AM	PM
Major Road approaching through traffic flow	$Q_{T1}$	22	22	24	23	
Major Road opposing through traffic flow	$Q_{T2}$	27	13	29	14	
Right turn traffic flow	$Q_R$	1	1	4	4	
Left turn traffic flow	$Q_L$	1	1	6	6	
Major Road traffic volume for right turn	$Q_M$	50	36	59	43	
Major Road traffic volume for left turn	$Q_M$	27	13	29	14	

Turn Warrant Graph (as adapted from Figure 3.25 Austroads Guide to Traffic Management Part 6 2020)

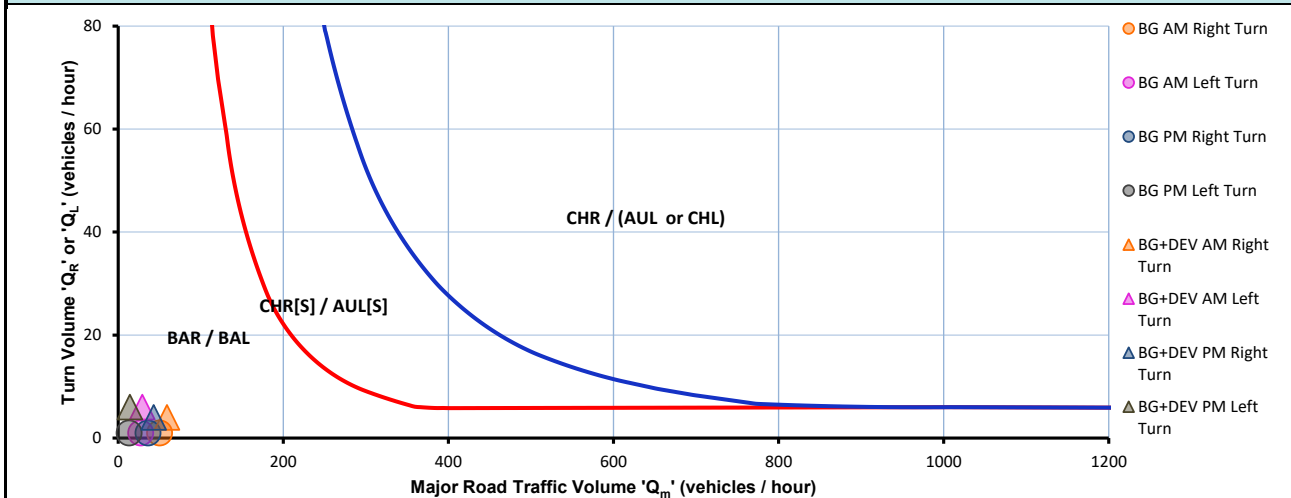
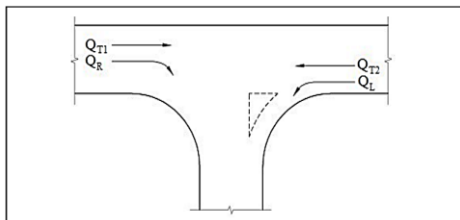

Figure 4A-A 4 - Calculation of the major road traffic volume parameter 'Q<sub>m</sub>'



Road Type	Turn Type	Splitter Island	Q <sub>m</sub> (veh/h)
2 Lane	Right	No	= $Q_{T1} + Q_{T2} + Q_L$
		Yes	= $Q_{T1} + Q_{T2}$
2 Way	Left	Yes/No	= $Q_{T2}$

**RESULTS:**

		BG	
		Right turn treatment	Left turn treatment
AM		BAR	BAL
PM		BAR	BAL
		BG+DEV	
		Right turn treatment	Left turn treatment
AM		BAR	BAL
PM		BAR	BAL

**NOTES:**

**WARRANTS FOR TURN TREATMENTS**

**PROJECT: 25E-0010 Poultry Farm - Torrumbarry**

**TITLE: 2052 PEAK HOUR TRAFFIC VOLUMES (Development Peak 1)**



**INTERSECTION DETAILS**

Major Road		Roslynmead Road
Side Road		Chrystal Road
Splitter Island on Major Road	Yes or No	No
Design Domain	NDD or EDD	NDD
Major Road Design Speed	(km/h)	More than/equal to 100

TRAFFIC VOLUMES (Vehicles/Hour)			BG		BG+DEV	
			AM	PM	AM	PM
Major Road approaching through traffic flow	$Q_{T1}$	4	16	5	17	
Major Road opposing through traffic flow	$Q_{T2}$	9	31	10	32	
Right turn traffic flow	$Q_R$	1	1	4	4	
Left turn traffic flow	$Q_L$	1	1	50	6	
Major Road traffic volume for right turn	$Q_M$	14	48	65	55	
Major Road traffic volume for left turn	$Q_M$	9	31	10	32	

Turn Warrant Graph (as adapted from Figure 3.25 Austroads Guide to Traffic Management Part 6 2020)

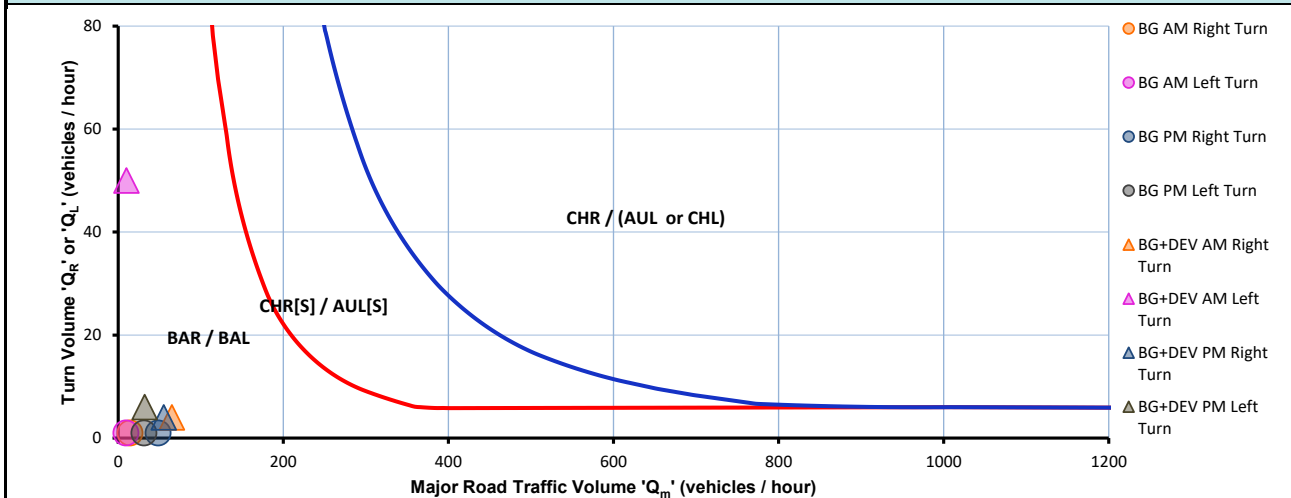
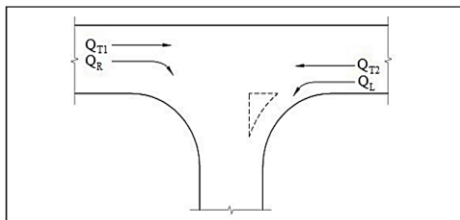

Figure 4A-A 4 - Calculation of the major road traffic volume parameter 'Q<sub>m</sub>'



Road Type	Turn Type	Splitter Island	$Q_m$ (veh/h)
2 Lane	Right	No	$= Q_{T1} + Q_{T2} + Q_L$
		Yes	$= Q_{T1} + Q_{T2}$
2 Way	Left	Yes/No	$= Q_{T2}$

**RESULTS:**

		BG	
		Right turn treatment	Left turn treatment
AM		BAR	BAL
PM		BAR	BAL
		BG+DEV	
		Right turn treatment	Left turn treatment
AM		BAR	BAL
PM		BAR	BAL

**NOTES:**

**WARRANTS FOR TURN TREATMENTS**

**PROJECT: 25E-0010 Poultry Farm - Torrumbarry**

**TITLE: 2052 PEAK HOUR TRAFFIC VOLUMES (Development Peak 2)**



**INTERSECTION DETAILS**

Major Road		Roslynmead Road
Side Road		Chrystal Road
Splitter Island on Major Road	Yes or No	No
Design Domain	NDD or EDD	NDD
Major Road Design Speed	(km/h)	More than/equal to 100

TRAFFIC VOLUMES (Vehicles/Hour)			BG		BG+DEV	
			AM	PM	AM	PM
Major Road approaching through traffic flow	$Q_{T1}$	36	18	38	19	
Major Road opposing through traffic flow	$Q_{T2}$	16	24	18	25	
Right turn traffic flow	$Q_R$	1	1	4	4	
Left turn traffic flow	$Q_L$	1	1	11	6	
Major Road traffic volume for right turn	$Q_M$	53	43	67	50	
Major Road traffic volume for left turn	$Q_M$	16	24	18	25	

Turn Warrant Graph (as adapted from Figure 3.25 Austroads Guide to Traffic Management Part 6 2020)

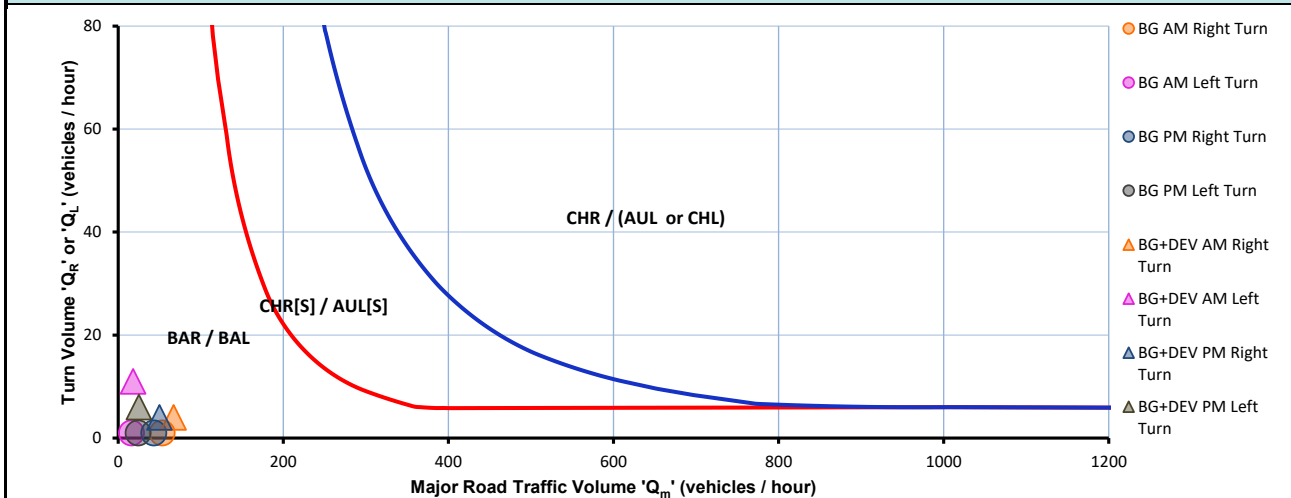
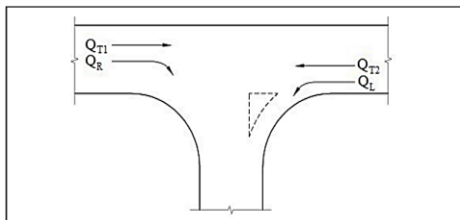

Figure 4A-A 4 - Calculation of the major road traffic volume parameter 'Q<sub>m</sub>'



Road Type	Turn Type	Splitter Island	$Q_m$ (veh/h)
2 Lane	Right	No	$= Q_{T1} + Q_{T2} + Q_L$
		Yes	$= Q_{T1} + Q_{T2}$
2 Way	Left	Yes/No	$= Q_{T2}$

**RESULTS:**

		BG	
		Right turn treatment	Left turn treatment
AM		BAR	BAL
PM		BAR	BAL
		BG+DEV	
		Right turn treatment	Left turn treatment
AM		BAR	BAL
PM		BAR	BAL

**NOTES:**

**WARRANTS FOR TURN TREATMENTS**

PROJECT: 25E-0010 Poultry Farm - Torrumbarry

TITLE: 2052 PEAK HOUR TRAFFIC VOLUMES (Network Peak)



**INTERSECTION DETAILS**

Major Road		Davis Road
Side Road		Site Access
Splitter Island on Major Road	Yes or No	No
Design Domain	NDD or EDD	NDD
Major Road Design Speed	(km/h)	More than/equal to 100

TRAFFIC VOLUMES (Vehicles/Hour)			0		BG+DEV	
			AM	PM	AM	PM
Major Road approaching through traffic flow	$Q_{T1}$	0	0	9	9	
Major Road opposing through traffic flow	$Q_{T2}$	0	0	9	0	
Right turn traffic flow	$Q_R$	0	0	0	0	
Left turn traffic flow	$Q_L$	0	0	6	5	
Major Road traffic volume for right turn	$Q_M$	0	0	24	14	
Major Road traffic volume for left turn	$Q_M$	0	0	9	0	

Turn Warrant Graph (as adapted from Figure 3.25 Austroads Guide to Traffic Management Part 6 2020)

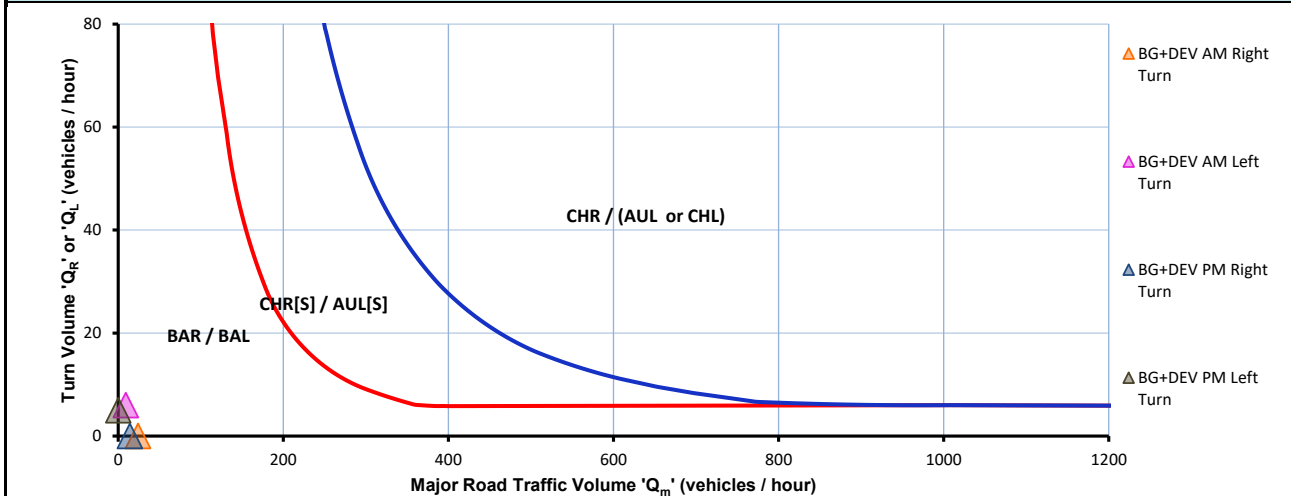
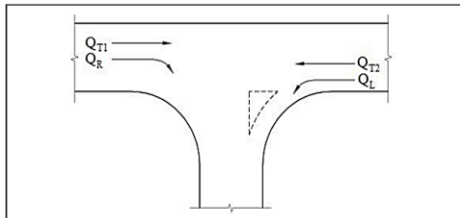

Figure 4A-A 4 - Calculation of the major road traffic volume parameter 'Q<sub>m</sub>'



Road Type	Turn Type	Splitter Island	Q <sub>m</sub> (veh/h)
2 Lane	Right	No	= $Q_{T1} + Q_{T2} + Q_L$
		Yes	= $Q_{T1} + Q_{T2}$
2 Way	Left	Yes/No	= $Q_{T2}$

**RESULTS:**

		0	
		Right turn treatment	Left turn treatment
AM			
PM			
		BG+DEV	
		Right turn treatment	Left turn treatment
AM		BAR	BAL
PM		BAR	BAL

**NOTES:**

**WARRANTS FOR TURN TREATMENTS**

**PROJECT: 25E-0010 Poultry Farm - Torrumbarry**

**TITLE: 2052 PEAK HOUR TRAFFIC VOLUMES (Development Peak 1)**



**INTERSECTION DETAILS**

Major Road		Davis Road
Side Road		Site Access
Splitter Island on Major Road	Yes or No	No
Design Domain	NDD or EDD	NDD
Major Road Design Speed	(km/h)	More than/equal to 100

TRAFFIC VOLUMES (Vehicles/Hour)			0		BG+DEV	
			AM	PM	AM	PM
Major Road approaching through traffic flow	$Q_{T1}$	0	0	0	9	
Major Road opposing through traffic flow	$Q_{T2}$	0	0	9	4	
Right turn traffic flow	$Q_R$	0	0	0	0	
Left turn traffic flow	$Q_L$	0	0	3	5	
Major Road traffic volume for right turn	$Q_M$	0	0	12	18	
Major Road traffic volume for left turn	$Q_M$	0	0	9	4	

Turn Warrant Graph (as adapted from Figure 3.25 Austroads Guide to Traffic Management Part 6 2020)

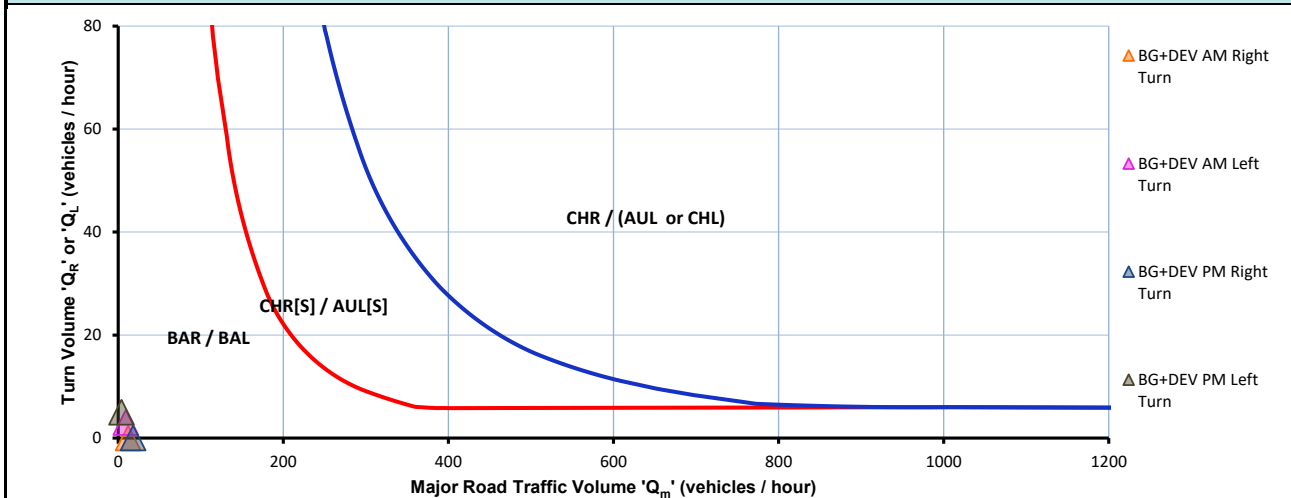
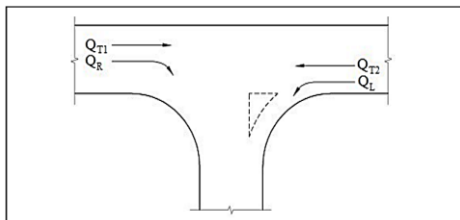

Figure 4A-A 4 - Calculation of the major road traffic volume parameter 'Qm'



Road Type	Turn Type	Splitter Island	Qm (veh/h)
2 Lane	Right	No	$= Q_{T1} + Q_{T2} + Q_L$
		Yes	$= Q_{T1} + Q_{T2}$
2 Way	Left	Yes/No	$= Q_{T2}$

**RESULTS:**

		0	
		Right turn treatment	Left turn treatment
AM			
PM			
		BG+DEV	
		Right turn treatment	Left turn treatment
AM		BAR	BAL
PM		BAR	BAL

**NOTES:**

**WARRANTS FOR TURN TREATMENTS**

**PROJECT: 25E-0010 Poultry Farm - Torrumbarry**

**TITLE: 2052 PEAK HOUR TRAFFIC VOLUMES (Development Peak 2)**



**INTERSECTION DETAILS**

Major Road		Davis Road
Side Road		Site Access
Splitter Island on Major Road	Yes or No	No
Design Domain	NDD or EDD	NDD
Major Road Design Speed	(km/h)	More than/equal to 100

TRAFFIC VOLUMES (Vehicles/Hour)			0		BG+DEV	
			AM	PM	AM	PM
Major Road approaching through traffic flow	$Q_{T1}$	0	0	7	13	
Major Road opposing through traffic flow	$Q_{T2}$	0	0	11	2	
Right turn traffic flow	$Q_R$	0	0	0	0	
Left turn traffic flow	$Q_L$	0	0	24	5	
Major Road traffic volume for right turn	$Q_M$	0	0	42	20	
Major Road traffic volume for left turn	$Q_M$	0	0	11	2	

Turn Warrant Graph (as adapted from Figure 3.25 Austroads Guide to Traffic Management Part 6 2020)

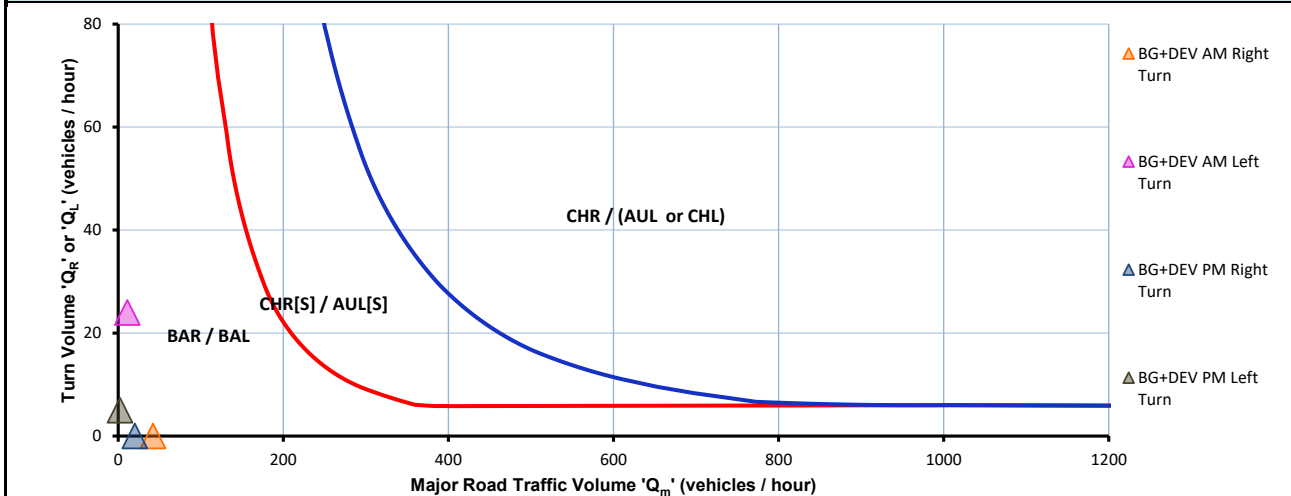
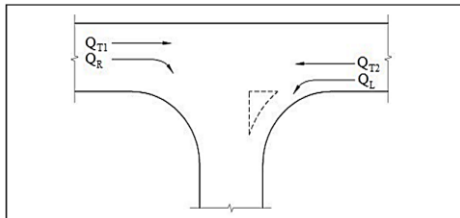

Figure 4A-A 4 - Calculation of the major road traffic volume parameter 'Q<sub>m</sub>'



Road Type	Turn Type	Splitter Island	Q <sub>m</sub> (veh/h)
2 Lane	Right	No	= $Q_{T1} + Q_{T2} + Q_L$
		Yes	= $Q_{T1} + Q_{T2}$
2 Way	Left	Yes/No	= $Q_{T2}$

**RESULTS:**

		0	
		Right turn treatment	Left turn treatment
AM			
PM			
		BG+DEV	
		Right turn treatment	Left turn treatment
AM		BAR	BAL
PM		BAR	BAL

**NOTES:**

**WARRANTS FOR TURN TREATMENTS**

**PROJECT: 25E-0010 Poultry Farm - Torrumbarry**

**TITLE: 2052 PEAK HOUR TRAFFIC VOLUMES (Network Peak)**



**INTERSECTION DETAILS**

Major Road		Chrystal Road
Side Road		Site Access
Splitter Island on Major Road	Yes or No	No
Design Domain	NDD or EDD	NDD
Major Road Design Speed	(km/h)	More than/equal to 100

TRAFFIC VOLUMES (Vehicles/Hour)		0		BG+DEV	
		AM	PM	AM	PM
Major Road approaching through traffic flow	$Q_{T1}$	0	0	5	5
Major Road opposing through traffic flow	$Q_{T2}$	0	0	6	6
Right turn traffic flow	$Q_R$	0	0	5	5
Left turn traffic flow	$Q_L$	0	0	2	2
Major Road traffic volume for right turn	$Q_M$	0	0	13	13
Major Road traffic volume for left turn	$Q_M$	0	0	6	6

Turn Warrant Graph (as adapted from Figure 3.25 Austroads Guide to Traffic Management Part 6 2020)

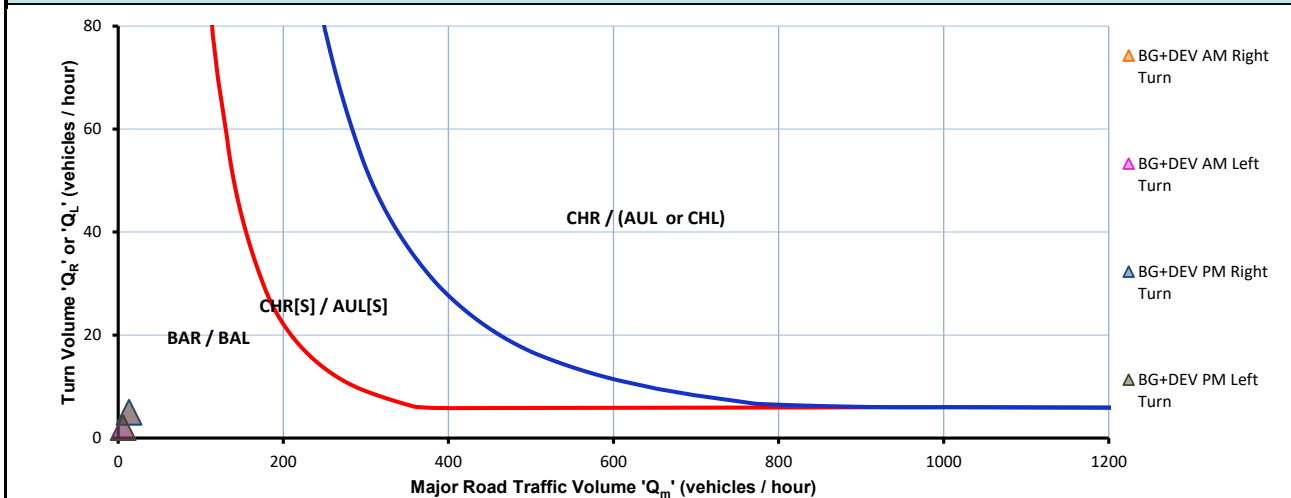
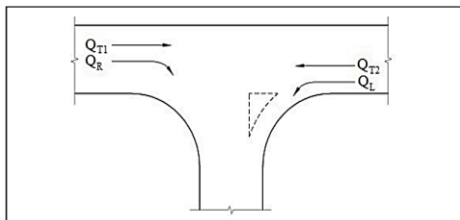

Figure 4A-A 4 - Calculation of the major road traffic volume parameter 'Q<sub>m</sub>'



Road Type	Turn Type	Splitter Island	Q <sub>m</sub> (veh/h)
2 Lane	Right	No	= $Q_{T1} + Q_{T2} + Q_L$
		Yes	= $Q_{T1} + Q_{T2}$
2 Way	Left	Yes/No	= $Q_{T2}$

**RESULTS:**

		0	
		Right turn treatment	Left turn treatment
AM			
PM			
		BG+DEV	
		Right turn treatment	Left turn treatment
AM		BAR	BAL
PM		BAR	BAL

**NOTES:**

**WARRANTS FOR TURN TREATMENTS**

PROJECT: 25E-0010 Poultry Farm - Torrumbarry

TITLE: 2052 PEAK HOUR TRAFFIC VOLUMES (Development Peak 1)



**INTERSECTION DETAILS**

Major Road		Chrystal Road
Side Road		Site Access
Splitter Island on Major Road	Yes or No	No
Design Domain	NDD or EDD	NDD
Major Road Design Speed	(km/h)	More than/equal to 100

TRAFFIC VOLUMES (Vehicles/Hour)		0		BG+DEV	
		AM	PM	AM	PM
Major Road approaching through traffic flow	$Q_{T1}$	0	0	5	5
Major Road opposing through traffic flow	$Q_{T2}$	0	0	6	6
Right turn traffic flow	$Q_R$	0	0	49	5
Left turn traffic flow	$Q_L$	0	0	2	2
Major Road traffic volume for right turn	$Q_M$	0	0	13	13
Major Road traffic volume for left turn	$Q_M$	0	0	6	6

Turn Warrant Graph (as adapted from Figure 3.25 Austroads Guide to Traffic Management Part 6 2020)

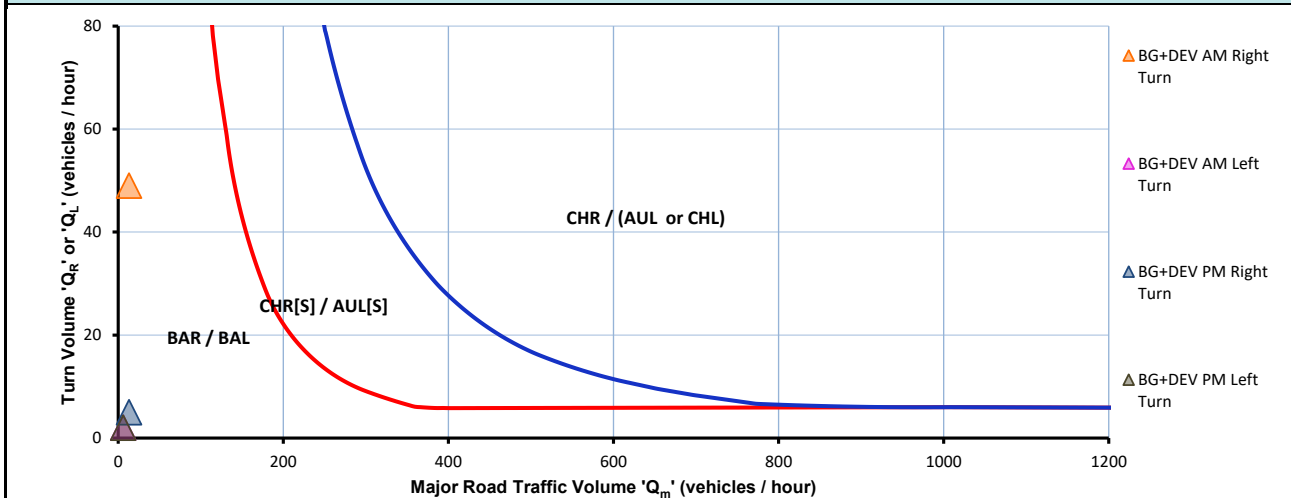
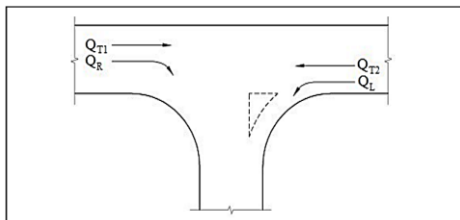

Figure 4A-A 4 - Calculation of the major road traffic volume parameter 'Q<sub>m</sub>'



Road Type	Turn Type	Splitter Island	Q <sub>m</sub> (veh/h)
2 Lane	Right	No	= $Q_{T1} + Q_{T2} + Q_L$
		Yes	= $Q_{T1} + Q_{T2}$
2 Way	Left	Yes/No	= $Q_{T2}$

**RESULTS:**

		0	
		Right turn treatment	Left turn treatment
AM			
PM			
		BG+DEV	
		Right turn treatment	Left turn treatment
AM		BAR	BAL
PM		BAR	BAL

**NOTES:**

**WARRANTS FOR TURN TREATMENTS**

**PROJECT: 25E-0010 Poultry Farm - Torrumbarry**

**TITLE: 2052 PEAK HOUR TRAFFIC VOLUMES (Development Peak 2)**



**INTERSECTION DETAILS**

Major Road		Chrystal Road
Side Road		Site Access
Splitter Island on Major Road	Yes or No	No
Design Domain	NDD or EDD	NDD
Major Road Design Speed	(km/h)	More than/equal to 100

TRAFFIC VOLUMES (Vehicles/Hour)			0		BG+DEV	
			AM	PM	AM	PM
Major Road approaching through traffic flow	$Q_{T1}$	0	0	10	5	
Major Road opposing through traffic flow	$Q_{T2}$	0	0	6	11	
Right turn traffic flow	$Q_R$	0	0	5	5	
Left turn traffic flow	$Q_L$	0	0	2	2	
Major Road traffic volume for right turn	$Q_M$	0	0	18	18	
Major Road traffic volume for left turn	$Q_M$	0	0	6	11	

Turn Warrant Graph (as adapted from Figure 3.25 Austroads Guide to Traffic Management Part 6 2020)

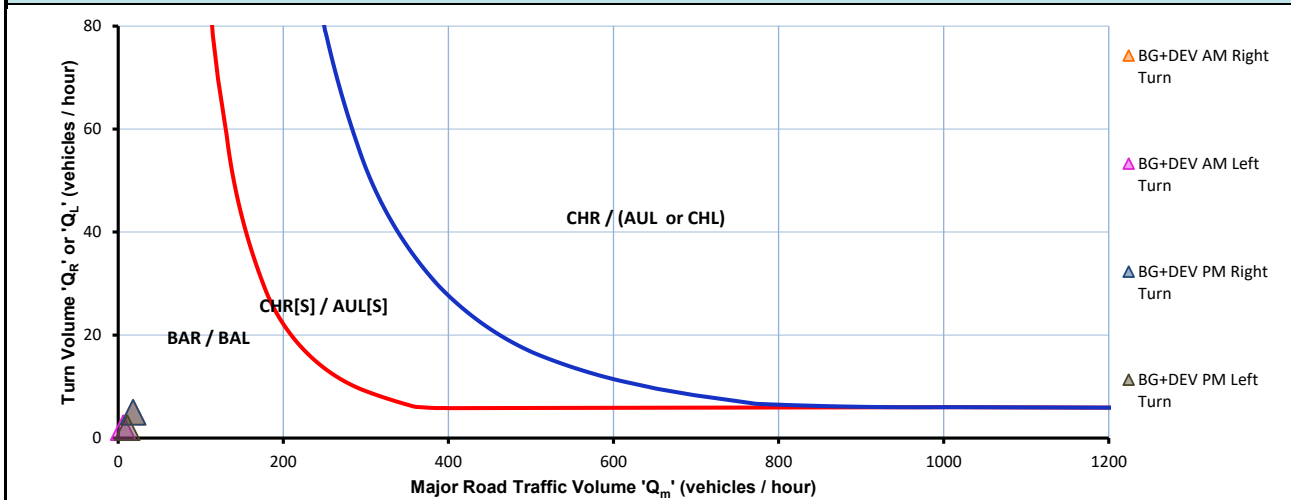
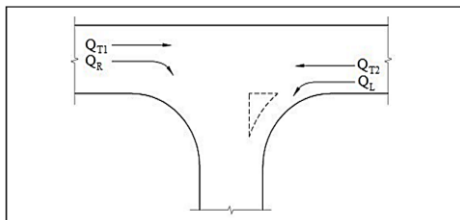

Figure 4A-A 4 - Calculation of the major road traffic volume parameter 'Q<sub>m</sub>'



Road Type	Turn Type	Splitter Island	$Q_m$ (veh/h)
2 Lane	Right	No	$= Q_{T1} + Q_{T2} + Q_L$
		Yes	$= Q_{T1} + Q_{T2}$
2 Way	Left	Yes/No	$= Q_{T2}$

**RESULTS:**

		0	
		Right turn treatment	Left turn treatment
AM			
PM			
		BG+DEV	
		Right turn treatment	Left turn treatment
AM		BAR	BAL
PM		BAR	BAL

**NOTES:**

## Appendix H Intersection concept sketches and swept path assessment

**25E-0010 – Murray Valley Highway / Davis Road**

Sketch plan - Revision 1 (31 July 2025)

Plans are for discussion purposes only | not to scale

Drawn by: Adam Gwatking (PE0017373)



**Murray Valley Highway / Davis Road intersection upgrade concept sketch (BAR / BAL layout)**

**25E-0010 – Murray Valley Highway / Davis Road**

Sketch plan - Revision 1 (31 July 2025)

Plans are for discussion purposes only | not to scale

Drawn by: Adam Gwatking (PE0017373)



**Murray Valley Highway / Davis Road – 19m AV turn path – Right In / Left Out**

**25E-0010 – Murray Valley Highway / Davis Road**

Sketch plan - Revision 1 (31 July 2025)

Plans are for discussion purposes only | not to scale

Drawn by: Adam Gwatking (PE0017373)



**Murray Valley Highway / Davis Road – 19m AV turn path – Left In / Right Out**

**25E-0010 – Murray Valley Highway / Heppell Road**

Sketch plan - Revision 1 (31 July 2025)

Plans are for discussion purposes only | not to scale

Drawn by: Adam Gwatking (PE0017373)



**Murray Valley Highway / Heppell Road intersection upgrade concept sketch (BAR / BAL layout)**

**25E-0010 – Murray Valley Highway / Heppell Road**

Sketch plan - Revision 1 (31 July 2025)

Plans are for discussion purposes only | not to scale

Drawn by: Adam Gwatking (PE0017373)

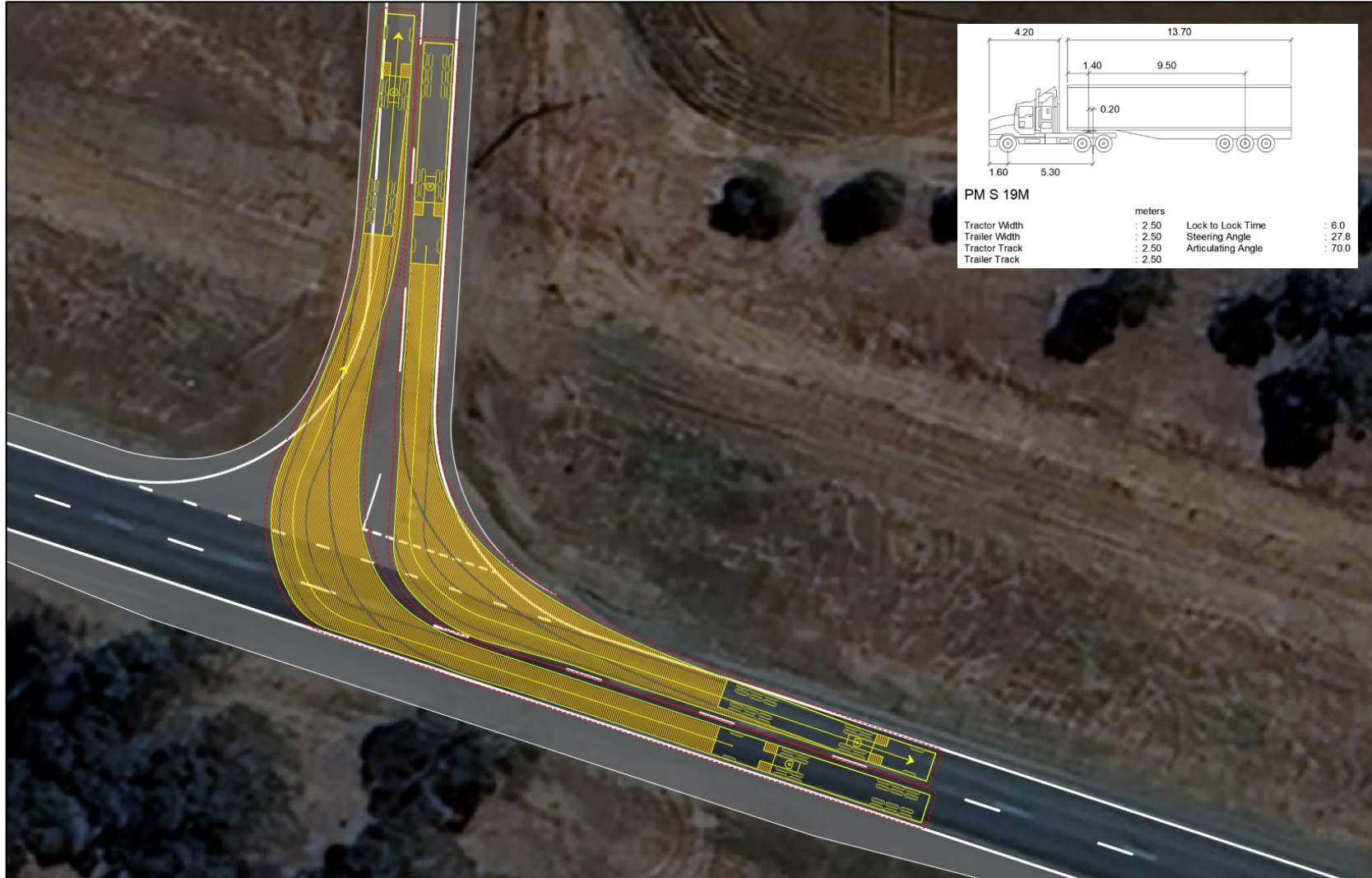

**Murray Valley Highway / Heppell Road – 19m AV turn path – Right In / Left Out**

**25E-0010 – Murray Valley Highway / Heppell Road**

Sketch plan - Revision 1 (31 July 2025)

Plans are for discussion purposes only | not to scale

Drawn by: Adam Gwatking (PE0017373)

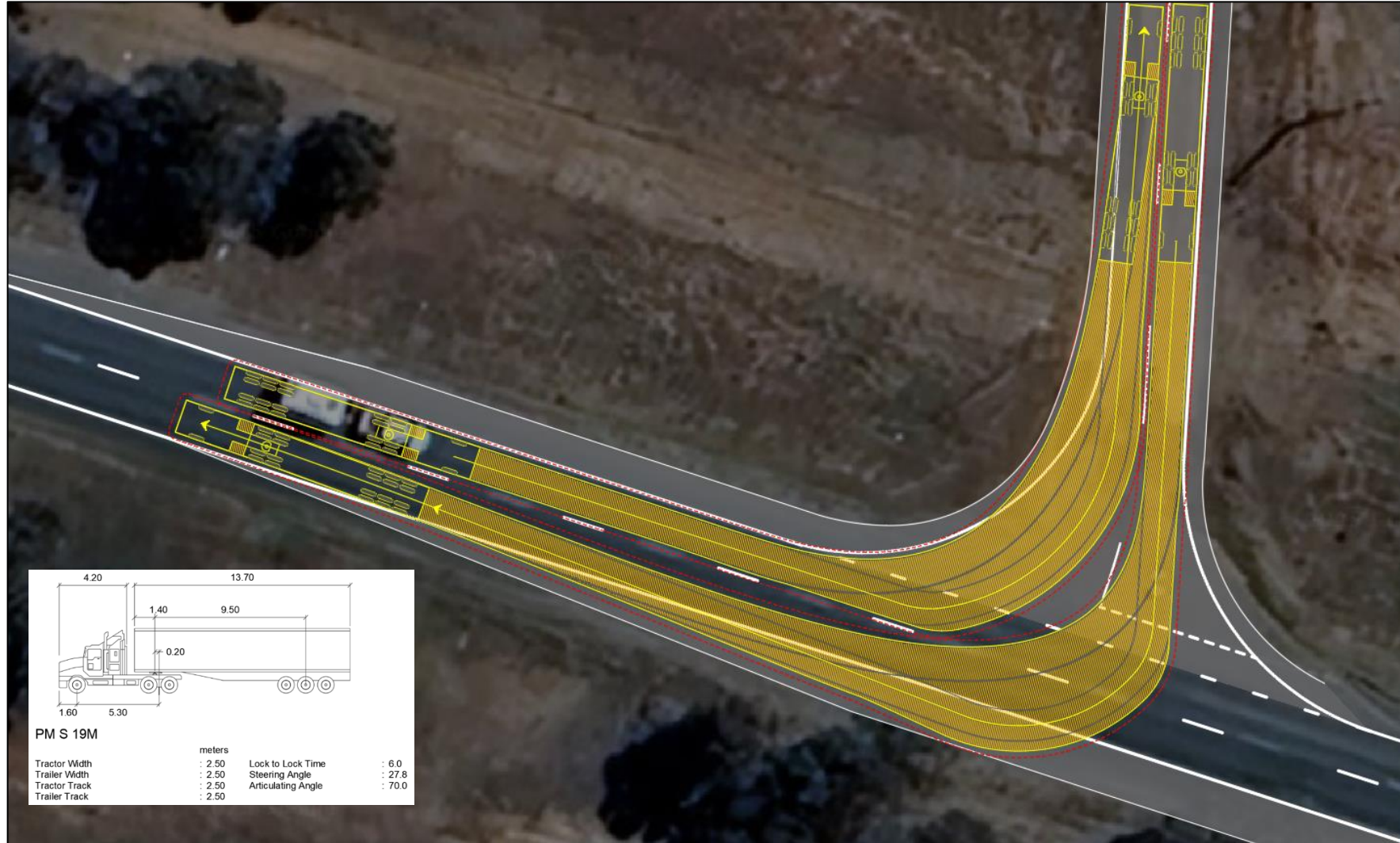

**Murray Valley Highway / Heppell Road – 19m AV turn path – Left In / Right Out**

**25E-0010 – Murray Valley Highway / Roslynmead Road**

Sketch plan - Revision 1 (31 July 2025)

Plans are for discussion purposes only | not to scale

Drawn by: Adam Gwatking (PE0017373)



**Murray Valley Highway / Roslynmead Road / Bail Road intersection upgrade concept sketch (CHR / CHR(S) / BAL layout)**

**25E-0010 – Murray Valley Highway / Roslynmead Road**

Sketch plan - Revision 1 (31 July 2025)

Plans are for discussion purposes only | not to scale

Drawn by: Adam Gwatking (PE0017373)



**Murray Valley Highway / Roslynmead Road – 19m AV turn path – Right In / Left Out**

**25E-0010 – Murray Valley Highway / Roslynmead Road**

Sketch plan - Revision 1 (31 July 2025)

Plans are for discussion purposes only | not to scale

Drawn by: Adam Gwatking (PE0017373)



**Murray Valley Highway / Roslynmead Road – 19m AV turn path – Left In / Right Out**

**25E-0010 – Roslynmead Road / Chrystal Road**

Sketch plan - Revision 1 (31 July 2025)

Plans are for discussion purposes only | not to scale

Drawn by: Adam Gwatking (PE0017373)

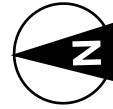

**Roslynmead Road / Chrystal Road intersection upgrade concept sketch (BAR / BAL layout)**

**25E-0010 – Roslynmead Road / Chrystal Road**

Sketch plan - Revision 1 (31 July 2025)

Plans are for discussion purposes only | not to scale

Drawn by: Adam Gwatking (PE0017373)

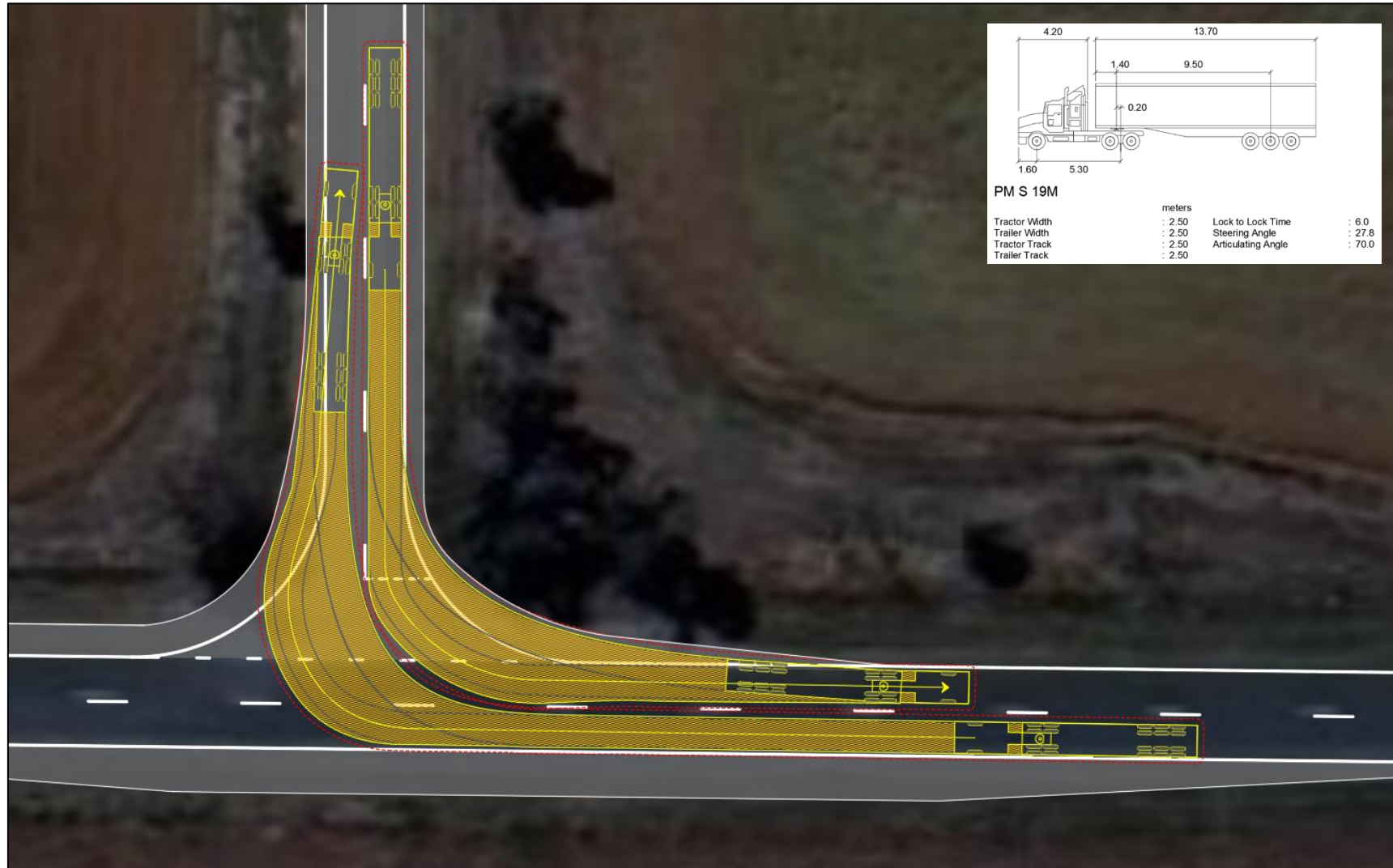
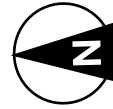

**Roslynmead Road / Chrystal Road – 19m AV turn path – Right In / Left Out**

**25E-0010 – Roslynmead Road / Chrystal Road**

Sketch plan - Revision 1 (31 July 2025)

Plans are for discussion purposes only | not to scale

Drawn by: Adam Gwatking (PE0017373)

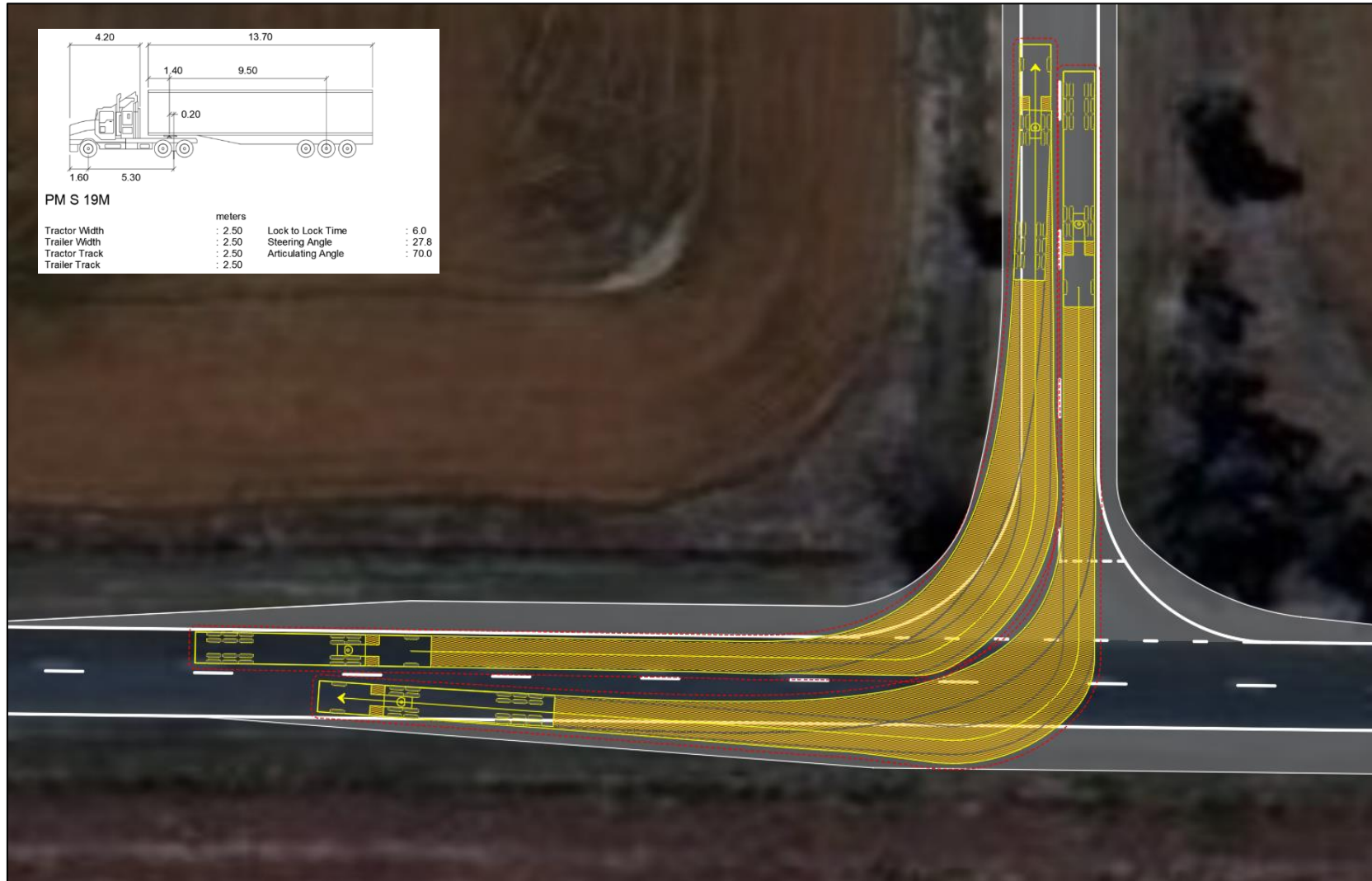
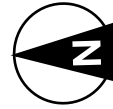

**Roslynmead Road / Chrystal Road – 19m AV turn path – Left In / Right Out**

**25E-0010 – Baillieu Road / Chrystal Road**

Sketch plan - Revision 1 (31 July 2025)

Plans are for discussion purposes only | not to scale

Drawn by: Adam Gwatking (PE0017373)

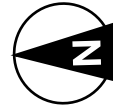

**Baillieu Road / Chrystal Road intersection upgrade concept sketch (simple right and simple left layout)**

**25E-0010 – Baillieu Road / Chrystal Road**

Sketch plan - Revision 1 (31 July 2025)

Plans are for discussion purposes only | not to scale

Drawn by: Adam Gwatking (PE0017373)

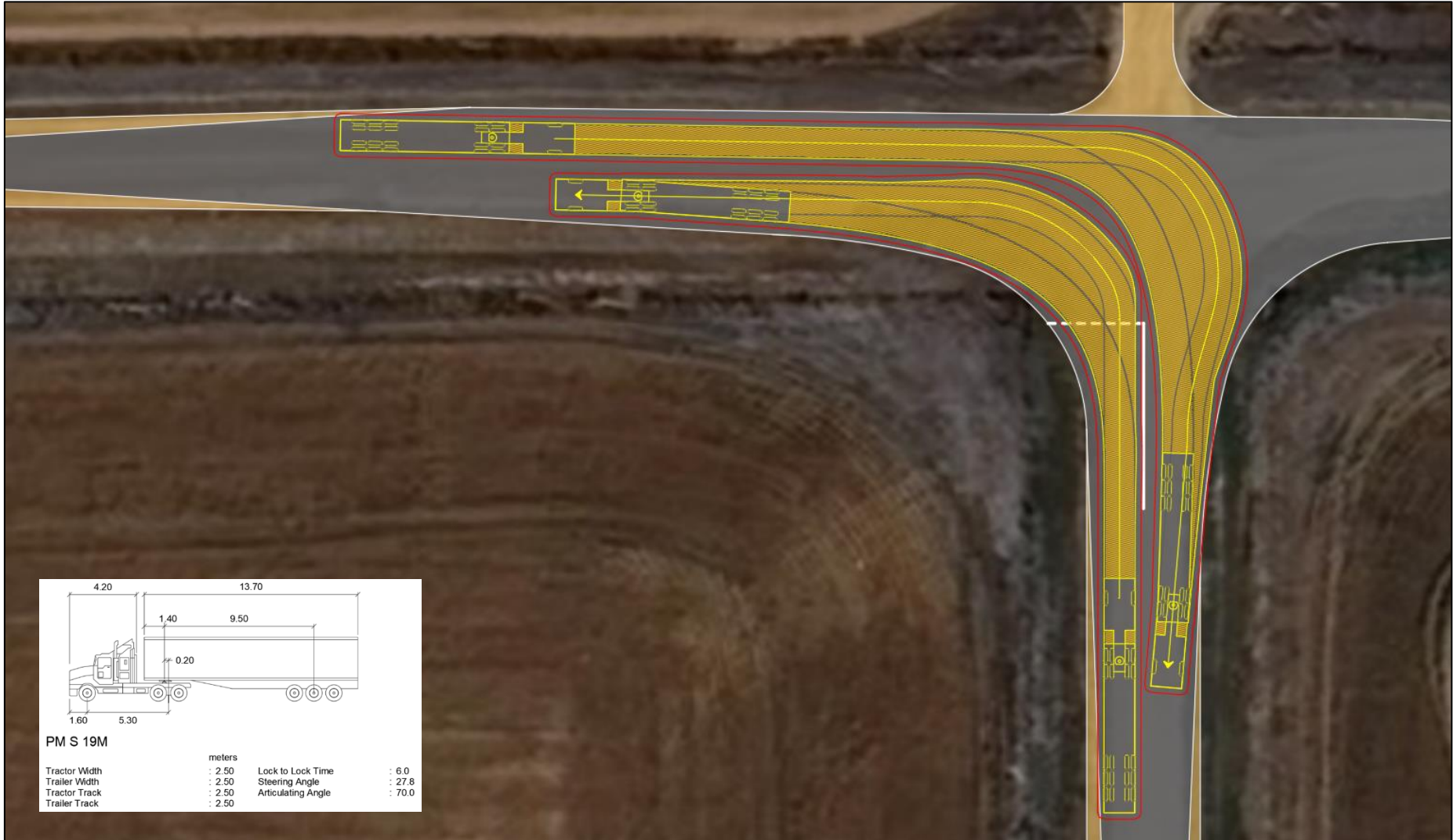
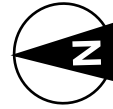

**Baillieu Road / Chrystal Road – 19m AV turn path – Right In / Left Out**

**25E-0010 – Baillieu Road curve widening**

Sketch plan - Revision 1 (31 July 2025)

Plans are for discussion purposes only | not to scale

Drawn by: Adam Gwatking (PE0017373)

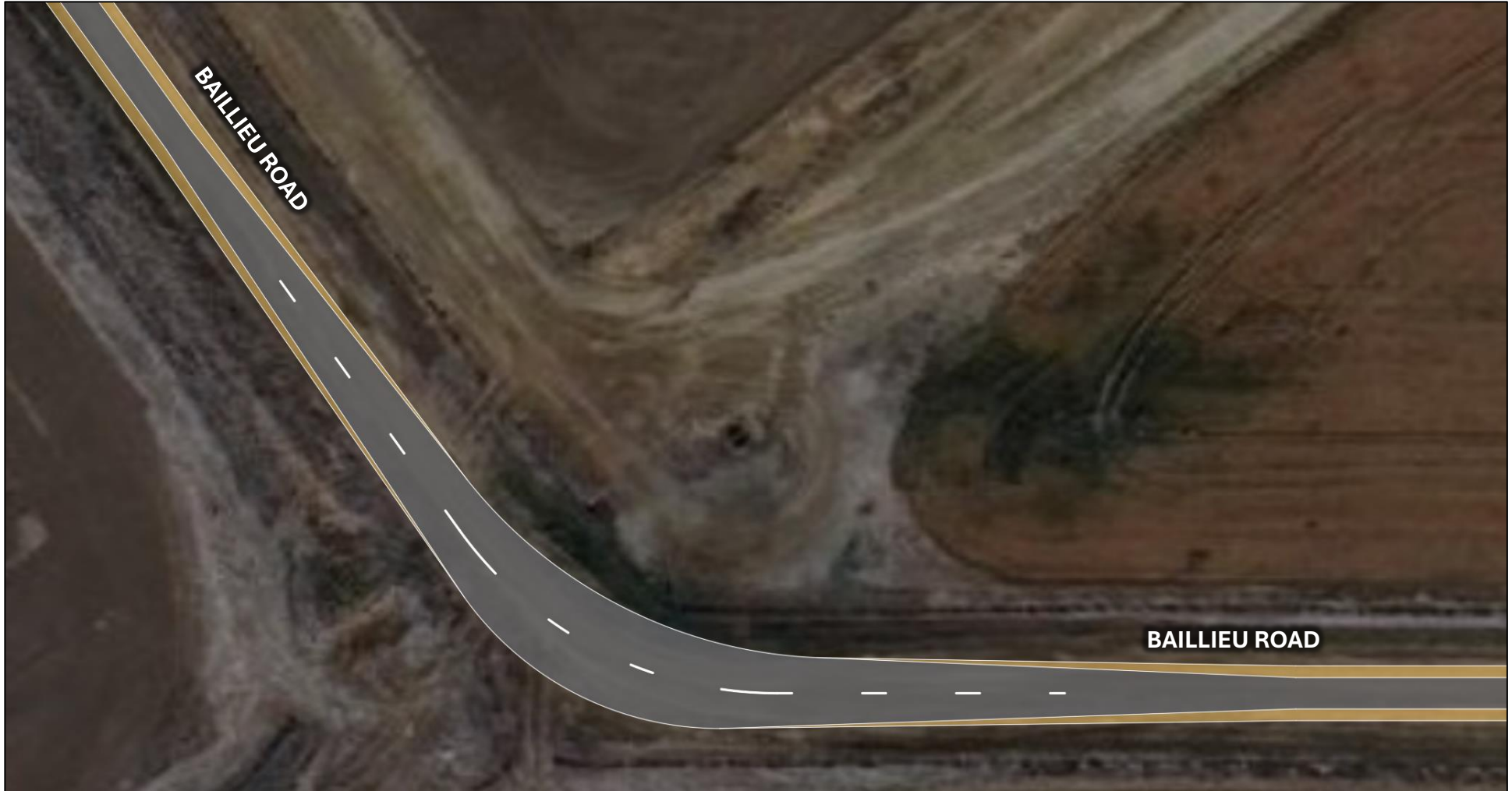

**Baillieu Road midblock curve upgrade concept sketch (curve widening)**

**25E-0010 – Baillieu Road curve widening**

Sketch plan - Revision 1 (31 July 2025)

Plans are for discussion purposes only | not to scale

Drawn by: Adam Gwatking (PE0017373)

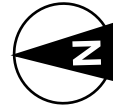

**Baillieu Road curve widening – 19m AV turn path – passing movements**

**Appendix I      Crash data provided by Transport for  
Victoria**

## ROAD CRASH INFORMATION SYSTEM

Location Formatted Report

UDA=User Defined Severity=All Casualty Date=01/01/2004 to 09/09/2025 ABS=ABS to receive accident

LGA	Map KM	Location	Severity K/SI/Inj Road User/Age/Sex/Injury	Date Time	Day DCA	Traf. Control Sub DCAs	Light Road	Veh Dir.	Units/ Object Hit	Accident No MF/Image
CAMPASPE	30 H2 405412	On MURRAY VALLEY HIGHWAY 232m E from Int PATHO SCHOOL ROAD	Serious injury 0/1/1 Pas/52/F/3 Pas/5/F/4 Pas/1/F/4 Dri/18/M/2	28/02/2010 19:50	Sun 172	No control V01	Dusk Dry	E*	Car/Not Applica	T20100007691 0/0
CAMPASPE	30 H2 405688	On MURRAY VALLEY HIGHWAY 44m W from Int PATHO SCHOOL ROAD	Fatal accident 1/1/0 Pas/85/M/1 Dri/74/F/2	20/01/2012 16:10	Fri 179	No control Q07	Day Dry	NW*	Station Wagon/G	T20120001497 0/0
CAMPASPE	30 H2 405644	At Int of MURRAY VALLEY HIGHWAY and PATHO SCHOOL ROAD	Other injury a 0/0/1 Dri/68/M/4 Dri/28/F/3	06/01/2023 06:55	Fri 111	No control NRQ	Day Dry	S* W^	LCVR <=4.5T/Not HV-RIGID > 4.5T	T20230000344 0/0
CAMPASPE	30 J2 5313	On GLENN ROAD 64m S from Int MURRAY VALLEY HIGHWAY	Other injury a 0/0/1 Mot/25/M/3	17/12/2005 09:00	Sat 182	No control V01 W01	Day Dry	N*	Motor Cycle/Not	T20060003213 0/0
CAMPASPE	30 J2 404418	On MURRAY VALLEY HIGHWAY 149m E from Int DAVIS ROAD	Fatal accident 1/0/0 Pas/64/F/4 Bic/52/F/1 Dri/67/M/4	28/11/2005 10:15	Mon 120	Other L03	Day Dry	E* W^	Bicycle/Not App Station Wagon	32005041949 0/0
CAMPASPE	30 J2 399134	On MURRAY VALLEY HIGHWAY 645m E from Int CAMERON ROAD	Other injury a 0/0/1 Dri/18/F/3	26/10/2013 01:05	Sat 171	No control Q02 V01	Dark Dry	NW*	Car/Tree (shrub)	T20130022070 0/0
CAMPASPE	30 J2 402393	On MURRAY VALLEY HIGHWAY 460m E from Int GLENN ROAD	Serious injury 0/1/0 Pas/69/M/4 Dri/73/M/2 Dri/27/F/4 Dri/43/M/4	19/07/2016 19:35	Tue 129	Other NRQ	Dark Dry	W* E^ E	Utility/Roadwor Car Utility	T20160015775 0/0
CAMPASPE	30 J2 402876	At Int of MURRAY VALLEY HIGHWAY and TORRUMBARRY WEIR ROAD	Serious injury 0/2/4 Pas/67/F/2 Pas/32/F/3 Pas/0/M/3 Pas/17/F/2 Dri/72/M/3 Dri/55/F/3	26/12/2017 12:30	Tue 132	No control N01	Day Dry	NW* NW^	Car/Not Applica Car	T20170024679 0/0
CAMPASPE	31 A2 398313	On MURRAY VALLEY HIGHWAY 690m W from Int BAXTER ROAD	Other injury a 0/0/1 Dri/44/M/3	09/03/2004 23:20	Tue 173	No control Q03 V01	Dark Dry	W*	Car/Fence/Wall	32004008077 0/0
CAMPASPE	31 A2 394916	On MURRAY VALLEY HIGHWAY 485m NW from Int YOUNG ROAD	Other injury a 0/0/1 Dri/23/F/3	17/03/2015 15:55	Tue 171	No control Q02 V01	Day Dry	NW*	Car/Tree (shrub)	T20150005689 0/0
CAMPASPE	31 A2 397321	On MURRAY VALLEY HIGHWAY 179m E from Int HEADWORKS ROAD	Serious injury 0/1/2 Pas/53/F/2 Dri/37/M/2 Dri/62/M/2	27/09/2017 09:09	Wed 120	No control L03	Day Dry	W* E^	Utility/Not App Station Wagon/N	T20170018471 0/0
CAMPASPE	31 A2 394431	On MURRAY VALLEY HIGHWAY 2m SE from Int YOUNG ROAD	Serious injury 0/1/1 Pas/38/F/3 Dri/70/M/2 Oth/30/M/4	05/06/2021 13:40	Sat 152	No control B02	Day Dry	E^ E*	Panel Van Plant machinery	T20210012519 0/0

Number of crashes: 12

Note : \* Indicates vehicle # 1 as per DCA chart; ^ Indicates vehicle #2 as per DCA chart

All users, please note details of abbreviation used to record heavy vehicle information:  
SEMI TRLR PT is Semi-Trailer (Pre-TIS); TRK EXCL SEMI PT is Truck (excluding semi)(Pre-TIS); PM ONLY is Prime Mover Only; PM SING TRLR is Prime Mover - Single Trailer; PM B-DOUBLE is Prime Mover - B-Double; PM B-TRIPLE is Prime Mover - B-TRIPLE; LCVR <=4.5T is Light Commercial Vehicle (Rigid) <=4.5 Tonnes GVM; HV-RIGID >4.5T is Heavy Vehicle (Rigid)>4.5 Tonnes GVM;

**ROAD CRASH INFORMATION SYSTEM**

Location Formatted Report

UDA=User Defined Severity=All Casualty Date=01/01/2004 to 09/09/2025 ABS=ABS to receive accident

9/09/2025

NB: Any complex intersections included in this report may not have had all accidents included.

## ROAD CRASH INFORMATION SYSTEM

Location Formatted Report

UDA=User Defined Severity=All Casualty Date=01/01/2004 to 09/09/2025 ABS=ABS to receive accident

9/09/2025

## ACCIDENTS BY YEAR AND SEVERITY and PERSONS INVOLVED BY YEAR AND INJURY LEVEL

Year	ACCIDENTS			Total Accidents	Killed	PERSONS			Total Persons
	Fatal	Serious Injury	Other Injury			Seriously Injured	Other Injury	Not Injured	
2004			1	1			1		1
2005	1		1	2	1		1	2	4
2010		1		1		1	1	2	4
2012	1			1	1	1			2
2013			1	1			1		1
2015			1	1			1		1
2016		1		1		1		3	4
2017		2		2		5	4		9
2021		1		1		1	1	1	3
2023			1	1			1	1	2

All users, please note details of abbreviation used to record heavy vehicle information:

SEMI TRLR PT is Semi-Trailer (Pre-TIS); TRK EXCL SEMI PT is Truck (excluding semi)(Pre-TIS); PM ONLY is Prime Mover Only; PM SING TRLR is Prime Mover - Single Trailer; PM B-DOUBLE is Prime Mover - B-Double; PM B-TRIPLE is Prime Mover - B-TRIPLE; LCVR <=4.5T is Light Commercial Vehicle (Rigid) <=4.5 Tonnes GVM; HV-RIGID >4.5T is Heavy Vehicle (Rigid)>4.5 Tonnes GVM;

## ROAD CRASH INFORMATION SYSTEM

Location Formatted Report

UDA=User Defined Severity=All Casualty Date=01/01/2004 to 09/09/2025 ABS=ABS to receive accident

DCA	DCA BY ACCIDENT SEVERITY			Total Accidents	Total Persons
	Fatal Accident	Serious Injury Accident	Other Injury Accident		
111			1	1	2
120	1	1		2	6
129		1		1	4
132		1		1	6
152		1		1	3
171			2	2	2
172		1		1	4
173			1	1	1
179	1			1	2
182			1	1	1

All users, please note details of abbreviation used to record heavy vehicle information:

SEMI TRLR PT is Semi-Trailer (Pre-TIS); TRK EXCL SEMI PT is Truck (excluding semi)(Pre-TIS); PM ONLY is Prime Mover Only; PM SING TRLR is Prime Mover - Single Trailer; PM B-DOUBLE is Prime Mover - B-Double; PM B-TRIPLE is Prime Mover - B-TRIPLE; LCVR <=4.5T is Light Commercial Vehicle (Rigid) <=4.5 Tonnes GVM; HV-RIGID >4.5T is Heavy Vehicle (Rigid)>4.5 Tonnes GVM;